



Energy That Moves Life



# Environmental and Social Impact Assessment (ESIA) of BQPS-III 900 MW RLNG Based Combined Cycle Power Plant (BQPS-III RLNG CCPP).



**Global Environmental Management Services (Pvt.) Ltd.**

2nd Floor, Aiwan-e-Sanat, ST-4/2, Sector 23, Korangi Industrial Area, Karachi

Ph: (92-21) 35113804-5; Fax: (92-21) 35113806; Email: [info@gems-intl.com](mailto:info@gems-intl.com)



# **K-Electric Limited**

## **Environmental & Social Impact Assessment (ESIA) of BQPS-III 900 MW RLNG Based Combined Cycle Power Project (BQPS-III RLNG CCPP).**

Final Report

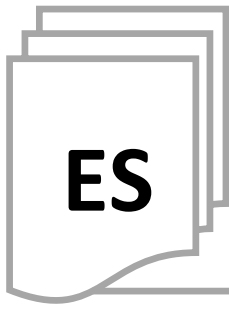
June, 2017



**Global Environmental Management Services (Pvt.) Ltd.**

2<sup>nd</sup> Floor, Aiwan-e-Sanat, ST-4/2, Sector 23, Korangi Industrial Area, Karachi

Ph: (92-21) 35113804-5; Fax: (92-21) 35113806; Email: [info@gems-intl.com](mailto:info@gems-intl.com)



# EXECUTIVE SUMMARY

## OVERVIEW

<b>Study Type</b>	Environmental and Social Impact Assessment (ESIA).
<b>Study Title</b>	ESIA of BQPS-III 900 MW RLNG Based Combined Cycle Power Project (BQPS-III RLNG CCPP).
<b>Location</b>	Port Qasim, Karachi Pakistan.
<b>Project Proponent</b>	K-Electric.
<b>Project Consultant</b>	Global Environmental Management Services (Pvt) Ltd. (GEMS)

This report discusses the Environmental and Social Impact Assessment (ESIA) of K-Electric, BQPS-III 900 MW RLNG Based Combined Cycle Power Project. The report also analyzes the impacts associated with the construction and operational phase of the proposed project and its surroundings, suggest mitigation measures, and identify residual impact which needs monitoring.

## PROPONENT’S PROFILE AND INTRODUCTION



K-Electric, commonly referred to as KE is a vertically integrated electric company involved in generating, transmitting and distributing power to over 2.5 million customers in Karachi and in the nearby towns of Dhabeji and Gharo in Sindh, and Hub, Uthal, Vinder and Bela in Balochistan. It employs over 10,000 people and covers 6,500 square kilometers with industrial, commercial, agricultural and residential areas falling under its network.

K-Electric has its own generation capacity of 2,267 MW, predominantly from its major Thermal Power Plants (BQPS I, BQPS II and KPC) and two Gas Engines Power Plants (SITE & Korangi), inclusive of 2 x 450 MW that has been added owing to the initiatives of the new management and the company inaugurated an additional 560 MW project in 2012. K-Electric being a prestigious and environmentally conscious organization wants to comply with all applicable laws and therefore intends to carry out the environmental impact assessment of its new Power Plant Project in Karachi.

## ENVIRONMENTAL CONSULTANT’S PROFILE AND INTRODUCTION



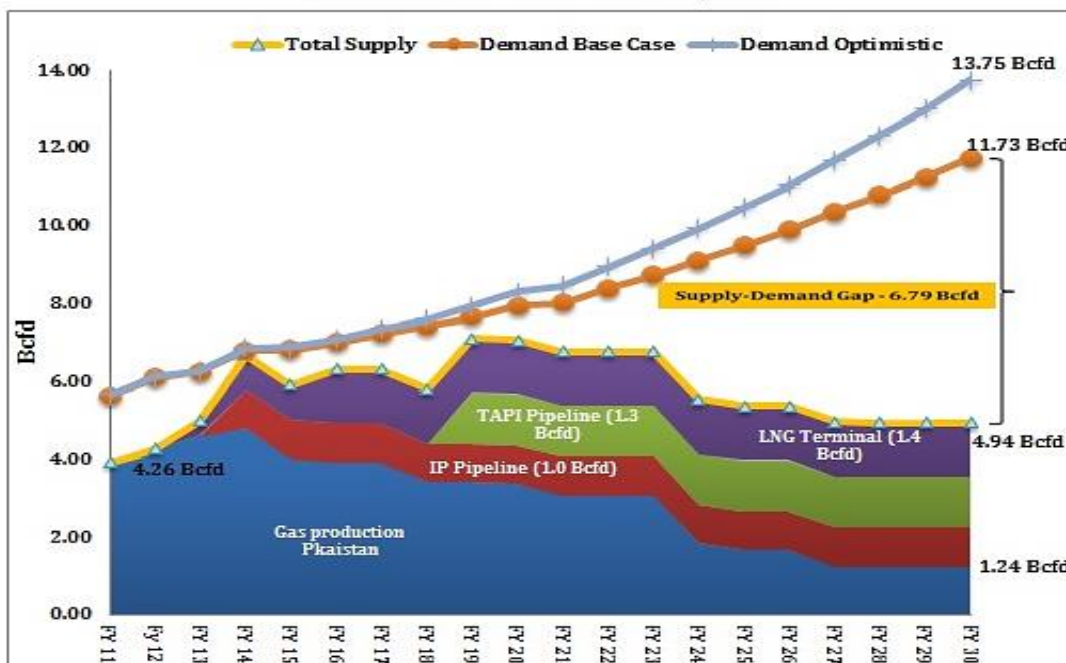
Global Environmental Management Services (Pvt.) Ltd. (GEMS) is an Environmental Consultancy which provides broad range of Environmental Solutions which are and not limited to Environmental Audits, Initial Environmental Examinations (IEE), Environmental and Social Impact Assessments (ESIA), Baseline studies and Training & Capacity building. GEMS is one of the few environmental firm having its own renowned ISO 17025 Certified Environmental Laboratory by the name of Global Environmental Laboratory (Pvt) Ltd.

## BACKGROUND INFORMATION AND NEED ASSESSMENT OF THE PROPOSED PROJECT

Pakistan is in the midst of a severe energy crisis that largely stemmed from mismanagement of natural resources in the country. Weak regulatory and pricing mechanisms in the natural gas sector have led to huge disparities between demand and supply. Pakistan has a large demand for natural gas and a well-established gas market and distribution system. At present, demand of natural gas is estimated at around 8 Billion Cubic Feet (BCF) against a total supply of 4 BCF, creating a shortfall of 4 BCF.

As per Pakistan Gas Supply-Demand Study conducted in 2012 by ILF BeratendeIngenieure GmbH, over the next 17 years gas demand is projected to stand at 11.73 BCFD, while domestic supplies are expected to reach the level of 4.94 BCFD resulting in a huge shortfall of about 6.79 BCFD by FY 2030. The analysis was done considering the existing and planned capacity. Below given Exhibit shows the yearly natural gas supply-demand project. A base case scenario is considered based on existing scenario i.e. business as usual.

### Natural Gas Demand Projections



Source: ILF Report on Gas/ Supply Demand Analysis and Base Gas Demand 2012

In order to meet the future energy challenges, to sustain and support economic growth, to mitigate the impact of widening shortfall, the Government has encouraged private investment LNG sector to establish an LNG Import projects under the LNG Policy 2002, 2006 & 2011.

To meet the shortfalls of electricity and to enhance the efficiency by reducing the demand-supply gap for the power consumers, KE has decided to install the Re-gasified Liquefied Natural Gas (RLNG) based 2 X 450 MW Combined Cycle Power Generation Units which will replace existing 2 x 210 MW unit 3 & 4 within the existing premises of BQPS-I along with new 132kv GIS Stations at Korangi west and Qayyumabad grids and the project will be titled as BQPS-III project. The proposed project aims to reduce environmental pollution while enhancing the system efficiency and power generation capacity in order to meet future energy challenges.

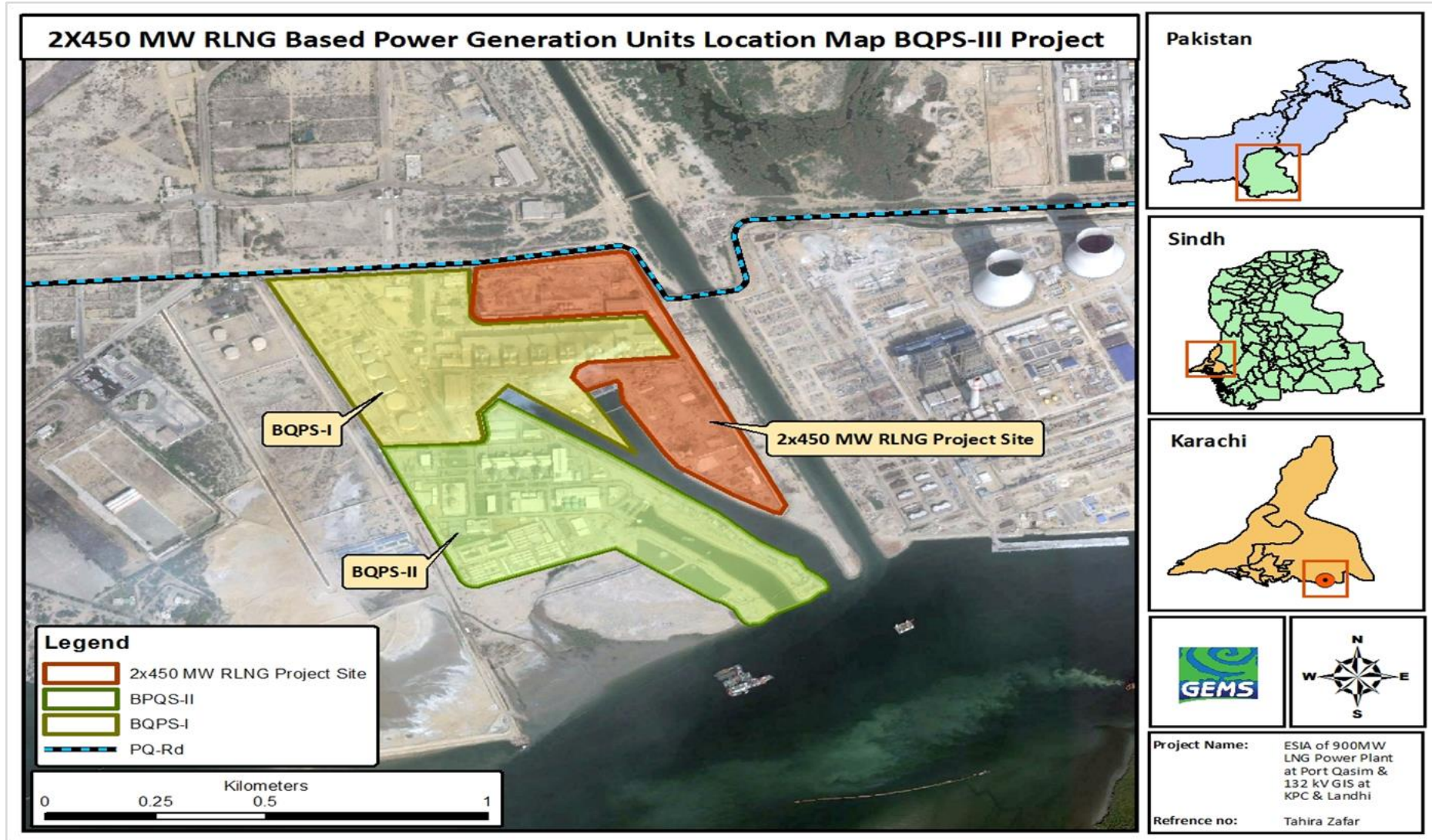
## PROPOSED PROJECT LOCATION

The proposed project mainly deals with 02 X 450 MW RLNG Based Combined Cycle Power Generation Units. It also includes installation of mechanical structures for power generation units at Port Qasim and at two Grid Stations and two Substations. Proposed installations for BQPS-III power project are presented below:

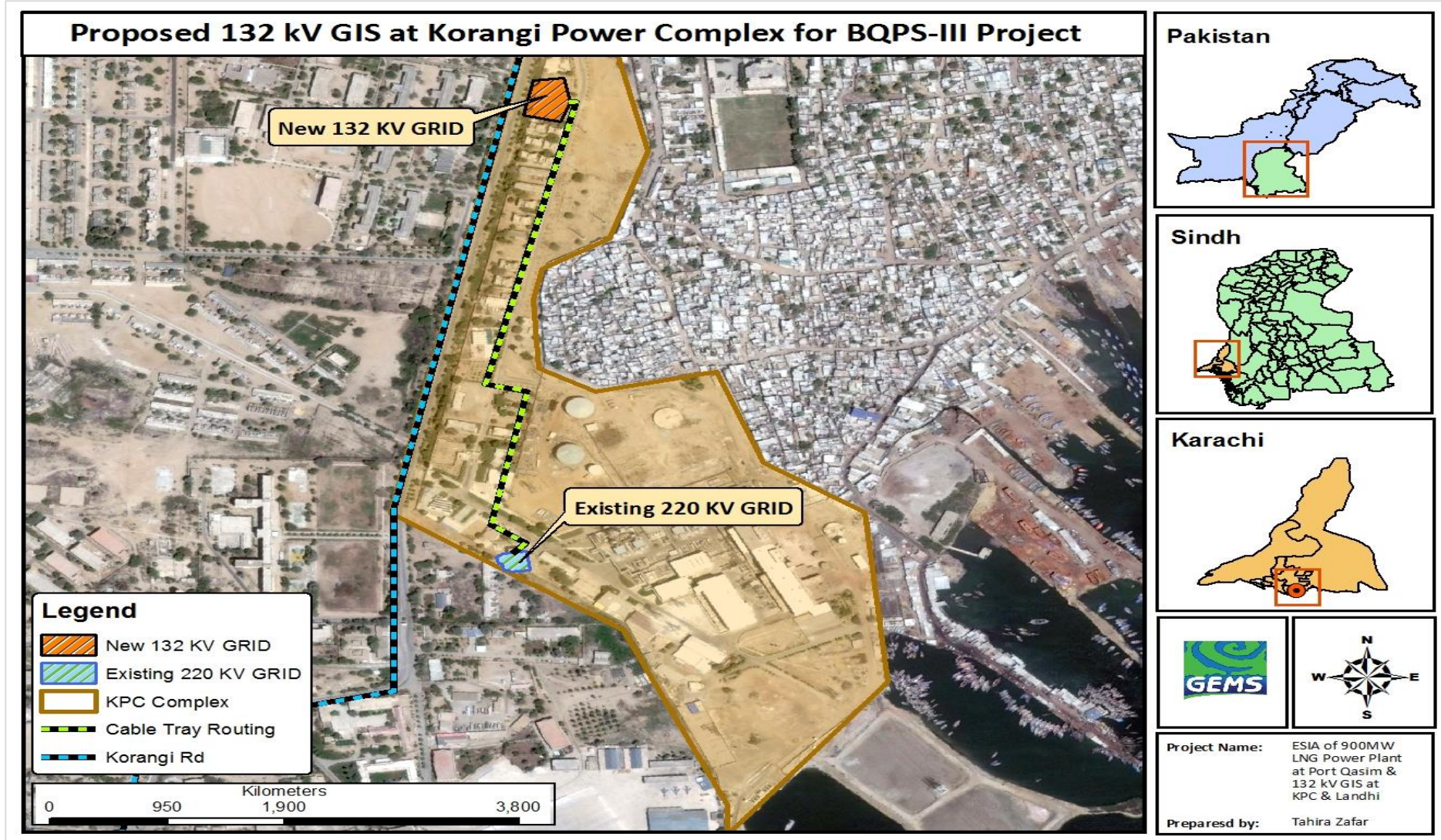
### Proposed Installations for BQPS-III Power Project

Proposed Installations	Location	Attachments
02 X 450 MW of RLNG Based Power Generation Unit	BQPS-I	Shown Below
01 X 220 kV GIS Grid Station	BQPS-I	
<b>01 X 220 kV ICI Switch Station</b>	Opposite BQPS-I	
01 X 132 kV GIS Grid Station	KPC	Shown Below
01 X 132 kV GIS Substation	Landhi Grid Station	Shown Below
01 X 132 kV GIS Substation	Korangi West and Qayyumabad	Shown Below

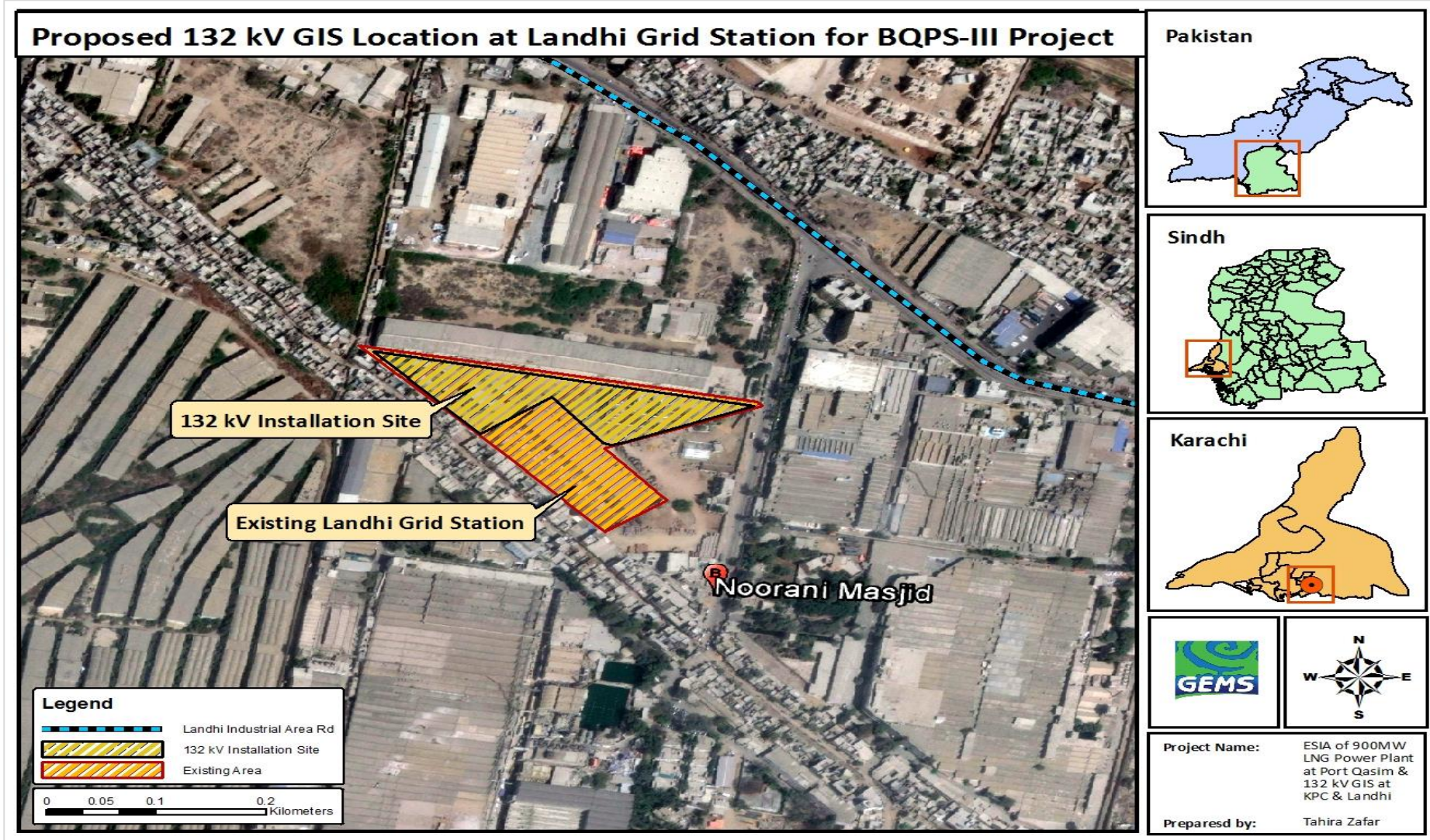
2 X 450 RLNG Based Power Generation Units Location Map for BQPS-III Project



01 132 kV GIS Grid Station at KPC for BQPS-III Project

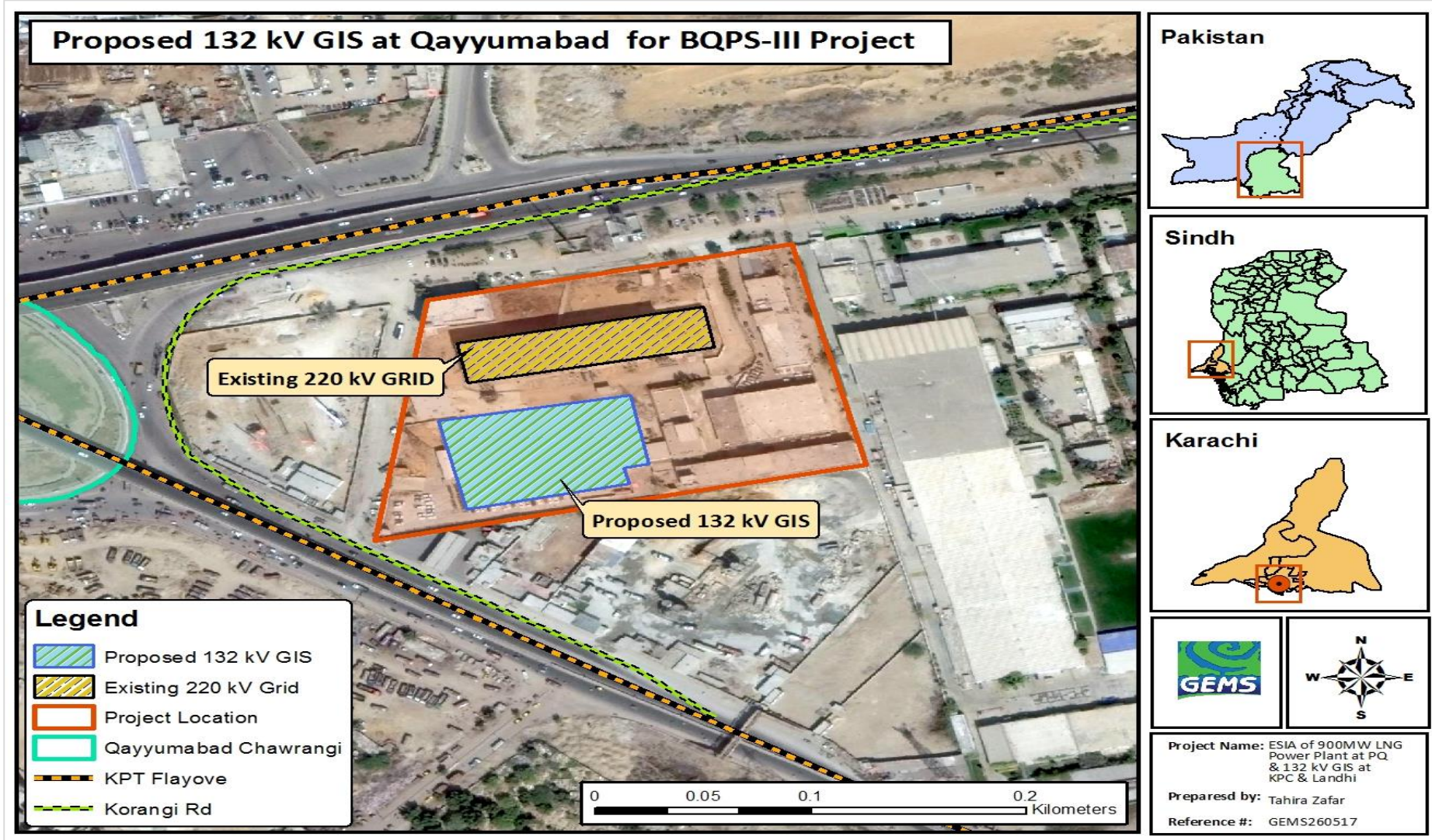


01 132 kV GIS Grid Station at Existing Landhi Grid Station





01 GIS Grid Station at Existing Qayyumabad Grid Station



## PROJECT DESCRIPTION

The proposed project includes construction of 02 X 450 R-LNG sets of 1+1+1 configuration Gas Turbine F class combined-cycle power generation units namely unit 7 & 8 inside the boundary of BQPS-I which will replace existing unit 3 and 4 with the installations of four Grid Stations at four different locations. The existing unit 3 and 4 are NG and HFO based power generation units of BQPS-I. Initially newly proposed unit-7 will operate in open cycle then unit-7 will be operated in combined cycle after decommissioning of unit-4 of BQPS-I. Then unit-8 will be installed after decommissioning of unit-3 and will operate in combined cycle. The proposed project needs a number of installations. The Proposed installation of 2 X 450 MW R-LNG Based Combined Cycle Power Generation Units 7 & 8 is given below:

- Gas Turbine House
- Heat Recovery Steam Generators (HRSG)
- Steam Turbine
- Bypass Stacks
- Gas Insulated Switchgear (GIS)
- Gas Compressor Station
- Transformers
- Cooling Water System
- Centralized Control Room (CCR)

## KEY BENEFITS OF THE PROPOSED POWER PROJECT

- Enhanced power capacity
- Efficient power generation
- Reduces emissions
- Greater operational flexibility

## LEGISLATIVE REQUIREMENT

The ESIA of the proposed Project activity will be subjected to the pertinent legislative and regulatory requirements of the Government of Sindh including State laws. Legislation presents a synopsis of environmental policies, legislation and other guidelines that have relevance to the proposed project.

The proposed project falls under the project category of **Schedule II, Category A Energy “Thermal power generation over 100MW”** as per the guidelines issued by the SEPA under the SEPA ACT, 2014. According to Sindh Environmental Protection Agency (Review of Initial Environmental Examination and Environmental Impact Assessment) Regulations, 2014, project under this category require an ESIA to be conducted at planning stage.

The two primary deliberations of the Act are the conduct of projects only after approval of environmental assessments from the SEPA and adherence with Sindh Environmental Quality Standards (SEQS).

**It is stated under section 17 of SEPA 2014:**

*“No proponent of a project shall commence construction or operation unless he has filed with the EPA an IEE or EIA, and has obtained from the EPA approval in respect thereof”.*

## **ENVIRONMENTAL BASELINE**

The proposed project area lies in the Malir District of Karachi at Port Qasim. The proposed 2 X 450 MW RLNG CCPGU project will include modifications within BQPS-I, KPC, Landhi and Qayyumabad Grid for power evacuation of the proposed project. However key focus remained on the main Project site, i.e. BQPS-III, which is located within the vicinity of PQA. The proposed project may impact the ambient air and noise quality during all phases through the release of gases and high noise level from construction and operation machinery and equipment. There are no significant natural freshwater resources observed in the proposed project area. The water used for drinking purpose was collected from BQPS-I facility and subjected to microbial and chemical analysis. Seawater samples were also collected from BQPS-I intake and outfall channel and subjected to environmental monitoring and testing.

Based on information available in the ESIA's for projects in Port Qasim, Korangi, Landhi as well as Qayyumabad and literature review, no threatened or endemic terrestrial plant species has been reported from the Study Area, with an exception on mangroves at Port Qasim. The Mangrove species *Avicenna marina* found in the proposed project area and *Rhizophora mucronanta* in the surroundings has been listed as least concern (LC), in IUCN red list of species, which endorsed its justification, as “This species is widespread and common throughout its range. It is a fast growing and fast regenerating, hardy species. It is threatened by the loss of mangrove habitat throughout its range, primarily due to extraction and coastal development. None of the MBI are listed as threatened, near threatened or as declining populations under the IUCN Red list of 2014.

## **SOCIOECONOMIC BASELINE**

The proposed project surrounding is less populated but it is rapidly growing as administrative towns of Karachi city. No human settlements are observed in the immediate vicinity of the proposed project however small Goths such as Rehri Goth and Lath Basti are small-scale settlements, which are about 10 to 13 km from the proposed project site on the North Western Zone of PQA. Pakistan Steel Mills is one of the significant landmarks of that area. Ibrahim Haidiri and Rehri Goth are the two biggest fishing communities of the proposed project site. Almost 90% of the fishing communities are directly or indirectly attached with fishing business and they totally rely on the mangroves forest for hunting of fish, crabs and shrimps. The proposed project surrounding sustains a number of industrial units, therefore a fully functional association referred to as Bin Qasim Association of Trade and Industry (BQATI) looks after general industrial matters and affairs.

The consultation meetings conducted specifically for this assignment, informal and focused group discussions with the primary and secondary stakeholders were carried out to disseminate information about the project and its expected impact on the primary and secondary stakeholders. A number of relevant stakeholders were consulted regarding the proposed project activities during different KIIs

(Key Informant Interviews) FGDs (Focused Group Discussions) and meetings. List of stakeholders consulted during the consultative workshop, FGDs and KIIs is presented below:

**List of Participants of Scoping Meeting Conducted on 26<sup>th</sup> April, 2017**

S. No	Name	Designation	Organization
1.	Dr. Sami uz Zaman	Chairman	Global Environmental Management Services (GEMS) Pvt. Ltd.
2.	Dr Shahid Amjad	Marine Biodiversity Expert	Institute of Business Management (IOBM)
3.	Mr. Rafi Ul Haq	Consultant Ecologist	Coastal Restoration Alliance for Biodiversity (CRAB)
4.	Mr. Imran Sabir	Deputy Director Technical	Sindh Environmental Protection Agency (SEPA)
5.	Mr. Saleem uz Zaman	Chief Executive	Global Environmental Management Services (GEMS) Pvt. Ltd.
6.	Mr. Chandar Parkash	General Manager – HSE G&T	K-Electric (KE)
7.	Mr. Fattah Moin Jah	Manager Strategic Planning & Business Development Department	K-Electric (KE)
8.	Muhammad Zeeshan Siddiqui	Deputy General Manager Strategic Planning & Business Development Department	K-Electric (KE)
9.	Mr. Mansoor Akram	Deputy Director	K-Electric (KE)
10.	Mr. Muhammad Tahir Qureshi	Senior Advisor	International Union for Conservation of Nature (IUCN) Pakistan
11.	Ms. Sharmeen Shafique	Information Officer	National Forum for Environment & Health (NFEH)
12.	Mr. Shoaib Abdul Razzak	Conservation officer	World Wildlife Fund (WWF) PAK
13.	Ms. Ayesha Sufyan	Conservation officer	World Wildlife Fund

S. No	Name	Designation	Organization
			(WWF) PAK
14.	Dr. Nuzhat Khan	Principle Scientific Officer	National Institute of Oceanography (NIO)
15.	Mr. Anwar Ali Memon	Legal Officer	Shehri, Citizen for Better Environment (CBE)
16.	Mr. Ali Rasheed	Executive Member	Shehri, Citizen for Better Environment (CBE)
17.	Dr. M Mansha	Director Earth Sciences	SUPARCO
18.	Mr.Jibran Khalid Kidwai	Project Coordinator	Global Environmental Management Services (GEMS)
19.	Engr:Kashif Noor	Environmental Engineer	Global Environmental Management Services (GEMS)
20.	Mr.Tayyab Shafique	Environmental & Social Consultation Expert	Global Environmental Management Services (GEMS)
21.	Ms. Kanwal Khatri	ESIA Technical Writer	Global Environmental Management Services (GEMS)
22.	Ms.Maria Kausar	Environmental Officer	Global Environmental Management Services (GEMS)
23.	Ms.Tahira	Environmental Officer	Global Environmental Management Services (GEMS)
24.	Engr: Musawir Munsif	Environmental Engineer	Global Environmental Management Services (GEMS)
<b>List of Participants of KILs during March, April 2017</b>			
1.	Dr. Zafar Iqbal Shams	Professor	Institute of Environmental Studies (UoK)
2.	Dr. Hashim Zuberi	Head of Department, Professor	Deptt: Of Environmental Science Sindh Madresatulislam University (SMIU)
3.	Mr. Shabbir Anwar Kazi	Director General Technical	Port Qasim Authority (PQA)
4.	Mr. Chen	Chief Commercial and Technical Depart	SEPCO

It was unanimously agreed by almost all the consultation participants that the proposed project seems to be environmentally sound and will contribute towards economic development. On the other hand it is important to note that as a nation Pakistan is moving towards industrialization and at this stage environment should be given due consideration and treated as priority and strict implementation of environmental health and safety standards should be ensured during the entire life cycle of the proposed project.

## **ANALYSIS OF ALTERNATIVES**

Analysis of alternatives is an integral part of the ESIA process to select the best option among all the possible project options. Analysis of alternatives is mainly based on following key aspects:

- Analysis of Project Refusal
- Analysis of Site Alternatives
- Analysis of Alternate technology/design

The “Project Refusal” alternative that means not proceeding with the proposed LNG based CCPGU and bringing no change to the baseline scenario. The proposed project aims to improve Pakistan’s energy balance and decrease the gap between its growing energy requirements and available energy supplies in the country by utilizing environmental friendly RLNG fuel instead of more expensive, diesel and furnace oil. The proposed project site is located within the existing area of BQPS-I.

BQPS-III project will be developed, adjacent to the BQPS-I which is already operational. Therefore, there was no site selection process for the present project. The power plant is designed to generate electricity by utilizing the maximum available resources. The GIS technology is designed for the proposed project and it is used as a compatible grid station option as it needs less space and is cost-effective in terms of maintenance.

## **ENVIRONMENTAL IMPACT AND MITIGATIONS**

The mitigations for the impacts identified and monitoring requirements are summarized in the Environmental Management and Monitoring Plan (EMMP) for the proposed BQPS-III 900 MW RLNG Based Combined Cycle Power Plant.

## **CONCLUSION**

ESIA of the proposed 02 X 450 MW RLNG Based CCPGU project has achieved the following goals:

Identification of national and provincial environmental regulatory requirements that apply to the proposed project activities;

Identification of the environmental features of the project area including the physical, biological and social disturbance and likely impact of the project on the environment;

Recommendation of appropriate mitigation measures that the project developer will incorporate and ensure as per this ESIA into the project to minimize the adverse environmental impacts.

After assessing the proposed project activities and investigating the proposed project area, the environmental consultants, GEMS have concluded that:

**" If the activities are undertaken as described in this ESIA report, and the recommended mitigation measures along with environmental management plan is adopted specifically, the proposed BQPS-III 900 MW RLNG Based Combined Cycle Power Plant project will not result in any long-term impacts on the physical and biological environment of the proposed project area. Additionally the proposed project installation will significantly contribute towards reduced environmental pressure in terms of air quality as natural gas is recognized as a comparatively clean burning fuel and it emits less particulates and negligible SO<sub>2</sub>, as well as less NO<sub>x</sub> and CO<sub>2</sub> than other fossil fuels. Moreover the proposed project will create employment opportunities for local residents and play vital role in overcoming the power shortfall in the country, since Karachi is the industrial hub of Pakistan thus the continuous power supply will not only boost the industrial and economic development of country but also result in a long-term net beneficial impact on air quality as well as social wellbeing of local community".**

### Impact Scaling Criteria

IMPACT SCALING CRITERIA			
Severity	Rating	Likelihood	Rating
HIGH	3	HIGH	3
MEDIUM	2	MEDIUM	2
LOW	1	LOW	1
IMPACT SCALE = SEVERITY X LIKELIHOOD			
HIGH = 7-9			
MEDIUM = 4-6			
LOW = 1-3			

#### SEVERITY

Impact severity has been categorized as follows:

**HIGH:** The anticipated environmental impact may adversely affect the environmental conditions.

**MEDIUM** The anticipated environmental impact may exhibit moderate affect onto the environmental conditions.

**LOW** The anticipated environmental impact is insignificant and may not affect the environmental conditions.

#### LIKELIHOOD

**HIGH:** The anticipated environmental impact is most likely to occur.

**MEDIUM** The anticipated environmental impact is likely to occur.

**LOW** The anticipated environmental anticipated environmental impact is less likely to occur.



### Environmental Management and Monitoring Plan

Aspect	Impact	Impact Scale <small>Severity X Likelihood</small>	Mitigation Safeguards	Residual Impact	Monitoring Parameter	Monitoring Location	Monitoring Frequency	Monitoring Responsibility
<b>Construction Phase</b>								
<b>Topography &amp; Landscape</b>	Formation of heaps due to improper handling of construction residue	1 X 2 = 2 <b>LOW</b>	<ul style="list-style-type: none"> <li>- Proper site leveling should be ensured, in order to minimize the probability of topographic changes at and project site flooding during rainy season</li> <li>- Ensure that construction material such as cement and or ready mix is handled properly and no residual material is left unattended so as to avoid the probability of formation of heaps and uneven structures</li> </ul>	1 X 1 = 1 <b>LOW</b>	Surface topography	Project sites at Port Qasim and Korangi Power Complex	Monthly	KE by engaging IEMC
<b>Ambient Air Quality</b>	Construction activities may result in following impacts:	2 X 2 = 4 <b>MEDIUM</b>	<ul style="list-style-type: none"> <li>- Use of standard construction equipment and vehicles;</li> <li>- Scheduled maintenance of back-up generators, equipment and vehicles including engine tuning, filter cleaning, etc.;</li> </ul>	2 X 1 = 2 <b>LOW</b>	Emissions of CO, NOX, PM10, and SOx from sources such as construction machineries and vehicle movement	All Project Installation and Modification Sites	Monthly	KE by engaging IEMC

Aspect	Impact	Impact Scale <small>Severity X Likelihood</small>	Mitigation Safeguards	Residual Impact	Monitoring Parameter	Monitoring Location	Monitoring Frequency	Monitoring Responsibility
	<p>Impairment of ambient air quality</p> <p>Chronic health issues</p> <p>Upper respiratory disorders</p>		<ul style="list-style-type: none"> <li>- Water spraying will be done to reduce dust emissions;</li> <li>- Enclosed painting booths and dedicated fabrication areas in favor of wind direction so the fumes may divert away from the site;</li> <li>- The vehicle speeds on graded roads will be limited in order to minimize dust emissions</li> </ul>					
<b>Noise</b>	<p>Headaches</p> <p>Hearing problems</p> <p>Accumulation of stress hormones</p> <p>Hypertension</p>	<p>2 X 2 = 4</p> <p><b>MEDIUM</b></p>	<ul style="list-style-type: none"> <li>- On site workers will be provided with adequate 'personal protective equipment' (PPE);</li> <li>- Construction equipment/ machineries will be provided with suitable silencers;</li> <li>- Regular maintenance of construction machinery and equipment will be ensured</li> </ul>	<p>2 X 1 = 2</p> <p><b>LOW</b></p>	<p>Noise levels and Construction Equipment/Machinery Maintenance Report</p>	<p>All Project Installation and Modification Sites</p>	<p>Monthly</p>	<p>KE by engaging IEMC</p>

Aspect	Impact	Impact Scale <small>Severity X Likelihood</small>	Mitigation Safeguards	Residual Impact	Monitoring Parameter	Monitoring Location	Monitoring Frequency	Monitoring Responsibility
			<ul style="list-style-type: none"> <li>- Construction activities will be scheduled / planned in such a way as to prevent high noise activities during night times and simultaneous operation of multiple high noise equipment will be avoided to the extent feasible</li> </ul>					
<b>Surface and Ground Water Quality</b>	Seawater contamination by oil spillage from construction vehicles and equipment	2 X 2 = 4 <b>MEDIUM</b>	<ul style="list-style-type: none"> <li>- All liquid raw material such as oil, lubricants and chemical at all project sites will be stored within the storage yard with impermeable floors and roof top.</li> <li>- The storage yard should be protected with secondary containment facility with appropriate labeling, to significantly reduce the chances of liquid waste or material discharge into the sea during the accidental spill or rain water runoff.</li> </ul>	1 X 1 = 1 <b>LOW</b>	pH, TSS, Temperature Oil and Grease and visual inspection of Surface Water Quality	Proposed project Site at Port Qasim	Monthly	KE by engaging IEMC

Aspect	Impact	Impact Scale <small>Severity X Likelihood</small>	Mitigation Safeguards	Residual Impact	Monitoring Parameter	Monitoring Location	Monitoring Frequency	Monitoring Responsibility
<b>Terrestrial Ecology</b>	Minimal mortality to plant life  Loss of foraging area for avifauna	2 X 1 = 2  <b>LOW</b>	<ul style="list-style-type: none"> <li>- Green areas will be developed in vacant portions of proposed project areas;</li> <li>- Best and safe industrial practices should be adopted for the less disturbance of ecology of the area.</li> </ul>	1 X 1 =1  <b>LOW</b>	Visual Inspection	Korangi Power Complex	Monthly Basis	KE by engaging IEMC
<b>Soil Quality</b>	Small scale excavations and site leveling may result in following impacts:  Soil erosion  Contamination of soil.	2 X 2 = 4  <b>MEDIUM</b>	<ul style="list-style-type: none"> <li>- Careful use of heavy machineries and equipment should be ensured in order to prevent leakages onto the soil.</li> <li>- A spill prevention response team will be available throughout all the activities for immediate action on site</li> </ul>	2 X 1 = 2  <b>LOW</b>	Visual Inspection	Proposed project sites at Port Qasim and Korangi Power Complex	Monthly Basis	KE by engaging IEMC
<b>Aquatic Ecology</b>	Small scale impact on aquatic ecosystem	2 X 2 = 4  <b>MEDIUM</b>	<ul style="list-style-type: none"> <li>- Existing drainage has bearing capacity of more effluent and will sustain rise in effluent</li> </ul>	2 X 1 = 2  <b>LOW</b>	Fish population density and productivity by fauna sampling and its laboratory analysis.	Proposed project Site at Port Qasim	Monthly	KE by engaging IEMC

Aspect	Impact	Impact Scale <small>Severity X Likelihood</small>	Mitigation Safeguards	Residual Impact	Monitoring Parameter	Monitoring Location	Monitoring Frequency	Monitoring Responsibility
			discharge caused during construction activities; - Construction activities will be performed with complete standard procedures and minimal discharge will be produced					
<b>Health &amp; Safety</b>	Lack of awareness among general laborers about safety may lead to accidents  Unskilled and untrained workers might cause harm to themselves and others  Construction works may	3 X 2 = 6  <b>MEDIUM</b>	- Ensure that hazards associated with manual lifting are controlled by proper lifting techniques, work rotation system will reduce the chances of being exposed to work related stress associated with construction activities. - Trained personnel will be appointed for the specific work - Unauthorized personnel will not be allowed to access the project site without permission and safety permits. - Arrangement of proper first aid unit and emergency vehicle to	2 X 1 = 2  <b>LOW</b>	HSE inspections  Risk assessment reports  Record of Safety Talks  Record of safety Incidents (Major & Minor)  Record of PPEs  Visual Assessments	All Project Installation and Modification Sites	Monthly	KE by engaging IEMC

Aspect	Impact	Impact Scale <small>Severity X Likelihood</small>	Mitigation Safeguards	Residual Impact	Monitoring Parameter	Monitoring Location	Monitoring Frequency	Monitoring Responsibility
	include many risks and hazards that may lead to severe injuries		take affected personnel to the nearest medical facility. - Workers should be facilitated by providing appropriate work specific PPE's; - Accidents records will be maintained					
<b>Road Safety and Traffic Management</b>	Traffic Congestion  Risk of accident	2 X 1 = 2  <b>LOW</b>	- Trained drivers and operators to drive the construction vehicles - Obey traffic and safety rules/precautions and traffic management plan.	1 X 1 = 1  <b>LOW</b>	Driver's license and traffic rules	NIL	NIL	NIL

Aspect	Impact	Impact Scale <small>Severity X Likelihood</small>	Mitigation Safeguards	Residual Impact	Monitoring Parameter	Monitoring Location	Monitoring Frequency	Monitoring Responsibility
<b>Livelihood &amp; Economy</b>	The proposed project will have positive impacts on local economy, however small scale conflicts between local vendors and project developer may occur	2 X 1 = 2 <b>LOW</b>	<ul style="list-style-type: none"> <li>- Specify time scale for construction activities</li> <li>- People from neighboring areas will be considered for unskilled employment</li> <li>- Suppliers and Vendors of neighboring areas will be given priority</li> <li>- Employment opportunities will be increased and the preference will be given to locals.</li> </ul>	1 X 1 = 1 <b>LOW</b>	Complaint register and Grievance Redress Mechanism (GRM)	All Project Installation and Modification Sites	Monthly	KE by engaging IEMC
<b>Solid waste</b>	Health hazards  Unaesthetic conditions	3 X 2 = 6 <b>MEDIUM</b>	<ul style="list-style-type: none"> <li>- Separate bins will be placed for different type of wastes - plastic, paper, metal, glass, wood, and cotton;</li> <li>- The material to be used during construction phase should be limited and should not exceed the needed amount so as to prevent solid waste production at project site.</li> </ul>	1 X 1 = 1 <b>LOW</b>	Visual inspections  Assessment of solid waste quantity and type	All Project Installation and Modification Sites	Monthly	KE by engaging IEMC

Aspect	Impact	Impact Scale <small>Severity X Likelihood</small>	Mitigation Safeguards	Residual Impact	Monitoring Parameter	Monitoring Location	Monitoring Frequency	Monitoring Responsibility
			<ul style="list-style-type: none"> <li>- No waste will be dumped at any location outside the proposed site boundary;</li> <li>- All hazardous waste will be separated from other wastes. Hazardous wastes will be disposed of through approved waste contractors;</li> <li>- Record all waste generated during the construction period will be maintained.</li> <li>- Training will be provided to personnel for identification, segregation, and management of waste.</li> </ul>					
<b>Operational Phase</b>								
<b>Air</b>	Chronic Respiratory health effects	2 X 3 = 6 <b>MEDIUM</b>	<ul style="list-style-type: none"> <li>- Ensure Fuel to Air Ratios are maintained;</li> <li>- Ensure power plant maintenance.</li> </ul>	2 X 1 = 3 <b>LOW</b>	CO and NOx	Project Site at Port Qasim	Quarterly	KE



Aspect	Impact	Impact Scale <small>Severity X Likelihood</small>	Mitigation Safeguards	Residual Impact	Monitoring Parameter	Monitoring Location	Monitoring Frequency	Monitoring Responsibility
			<ul style="list-style-type: none"> <li>- Ensure Fuel to be used of approved quality</li> </ul>					
<b>Noise</b>	<p>Power plant operations may result in elevated levels of noise which may result in following impacts:</p> <p>Stress Hypertension Hearing loss Headache</p>	<p>1 X 3 = 3</p> <p><b>LOW</b></p>	<ul style="list-style-type: none"> <li>- KE Employees accessing the area will always wear PPE's like ear protection muffs or ear plugs;</li> <li>- Proper maintenance of all the equipment to be utilized during operational phase will be maintained throughout the entire life cycle of the proposed project</li> <li>- Unauthorized personnel will not be allowed to access high noise areas.</li> </ul>	<p>1 X 2 = 2</p> <p><b>LOW</b></p>	Noise levels	Project Site at Port Qasim	Quarterly	KE
<b>Aquatic Environment</b>	<p>Change in diversity of benthic community</p> <p>Water pollution</p>	<p>2 X 3 = 6</p> <p><b>MEDIUM</b></p>	<ul style="list-style-type: none"> <li>- Retain effluent prior to final discharge for treatment unless the quality remains within SEQs;</li> <li>- The treated water can be reutilized for green areas</li> </ul>	<p>2 X 1 = 2</p> <p><b>LOW</b></p>	<p>MBI</p> <p>Marine outfall Parameters as per SEQs or SEPA requirement</p>	Benthic faunal sampling stations at outfall and intake channel of BQPS-III at Port Qasim	Quarterly	KE

Aspect	Impact	Impact Scale <small>Severity X Likelihood</small>	Mitigation Safeguards	Residual Impact	Monitoring Parameter	Monitoring Location	Monitoring Frequency	Monitoring Responsibility
<b>Health &amp; Safety</b>	<p>Lack of awareness among general laborers about safety may lead to accidents</p> <p>Unskilled and untrained workers might cause harm to themselves and others</p> <p>Health hazards</p>	<p>2 X 3 = 6</p> <p><b>MEDIUM</b></p>	<ul style="list-style-type: none"> <li>- Ensure that all the safety and security procedures are in place and implemented in true spirit.</li> <li>- Ensure proper maintenance of firefighting systems during the entire life cycle of the proposed project.</li> <li>- Necessary training regarding safety aspects to the personnel working at the project site will be given.</li> <li>- Material Safety Data Sheet (MSDS) for chemicals, if any, will accompany the consignment.</li> <li>- The project developer must ensure implementation of proper HSE policy at all project locations so as to reduce the chances of occurrence of frequent hazards.</li> </ul>	<p>2 X 2 = 4</p> <p><b>MEDIUM</b></p>	<p>Record of Safety Talks</p> <p>Record of safety Incidents (Major &amp; Minor)</p> <p>Record of PPEs</p> <p>Visual Assessments</p>	All Project Installation and Modification Sites	Monthly	KE

Aspect	Impact	Impact Scale <small>Severity X Likelihood</small>	Mitigation Safeguards	Residual Impact	Monitoring Parameter	Monitoring Location	Monitoring Frequency	Monitoring Responsibility
<b>Livelihood and Economy</b>	<p>Proposed project will reduce the energy deficit of Karachi.</p> <p>people will benefit in form of employment and business activities</p> <p>Operational phase activities can cause health and safety risk</p>	<p>2 X 1 = 2</p> <p><b>LOW</b></p>	<ul style="list-style-type: none"> <li>- Possibility of recruitment of local workers having pertinent education skills will be explored;</li> <li>- Local businesses such as fabricators, maintenance service providers, food suppliers, transporters, etc., are likely to have business opportunities associated with the operation of the plant</li> <li>- Mechanism will be developed for local community engagement for complaints and suggestions;</li> </ul>	<p>1 X 1 = 1</p> <p><b>LOW</b></p>	<p>Complaint register and Grievance Redress Mechanism (GRM)</p> <p>Local Consultations records</p>		As and when required	KE

Aspect	Impact	Impact Scale <small>Severity X Likelihood</small>	Mitigation Safeguards	Residual Impact	Monitoring Parameter	Monitoring Location	Monitoring Frequency	Monitoring Responsibility
<b>Water and Waste Water</b>	Heated effluent discharge and untreated wastewater may result in seawater pollution and impacts on aquatic ecology	2 X 2 = 4 <b>MEDIUM</b>	<ul style="list-style-type: none"> <li>- Appropriate facilities to be provided for collection, storage and routing the wastewater streams to treatment plant and facilities are to be provided;</li> <li>- Appropriate sludge handling and disposal facilities are to be provided for waste treatment sludge.</li> <li>- Effluent sewers to be periodically cleaned and inspected for integrity;</li> <li>- Sanitary wastewater from all sections of the facility to be collected and routed to sanitary treatment system</li> <li>- All run off from the process area to be routed for treatment prior to disposal.</li> </ul>	2 X 1 = 2 <b>LOW</b>	Parameters as per SEQs or SEPA requirements	Water sampling stations at outfall and intake channel of BQPS-III at Port Qasim	Monthly	KE
<b>Solid waste</b>	Health impacts	2 X 3 = 6 <b>MEDIUM</b>	<ul style="list-style-type: none"> <li>- The solid waste management plan will be developed and facilities for collection, storage</li> </ul>	2 X 1 = 2 <b>LOW</b>	Within the site premises	All Project Installation and	Monthly	KE

Aspect	Impact	Impact Scale <small>Severity X Likelihood</small>	Mitigation Safeguards	Residual Impact	Monitoring Parameter	Monitoring Location	Monitoring Frequency	Monitoring Responsibility
	Unaesthetic view  Property loss  Unhygienic conditions		and transportation will be established and organized;  - A safe and designated area will be selected for disposal of waste and EPA certified contractors will be hired;  - Dumping of solid waste will be prohibited around the facilities.			Modification Sites		

# LIST OF CONTENTS

---

## EXECUTIVE SUMMARY

### 1.0 INTRODUCTION

1.1	OVERVIEW	1-1
1.2	PROJECT BACKGROUND	1-1
1.3	NEED ASSESSMENT	1-2
1.4	PROPONENT'S PROFILE	1-3
1.5	CONSULTANT'S PROFILE	1-3
	1.5.1 Consultancy Division	1-3
	1.5.2 Laboratory Division	1-4
	1.5.3 Waste Management Division	1-4
1.6	ESIA STUDY TEAM	1-5
1.7	LEGISLATIVE REQUIREMENT	1-5
1.8	PURPOSE OF THE STUDY	1-5
1.9	SCOPE OF THE ESIA	1-6
1.10	APPROACH AND METHODOLOGY	1-6
	1.10.1 Scoping	1-6
	1.10.2 Baseline Studies	1-7
	1.10.3 Impact Assessment	1-7
	1.10.4 Documentation	1-8

### 2.0 PROJECT DESCRIPTION

2.1	GENERAL OUTLINE AND SCOPE	2-1
2.2	PROPOSED PROJECT LOCATION	2-1
2.3	TECHNICAL DESCRIPTION	2-7
	2.3.1 Installations within the Existing Premises of BQPS-I for Proposed BQPS-III Power Project	2-7
	2.3.2 Modifications within the Existing Premises of KPC for Proposed BQPS-III Power Project	2-12
	2.3.3 Modifications within the Existing Premises of Landhi Grid Station for Proposed BQPS-III Power Project	2-13
	2.3.4 Modifications within the Existing Premises of Qayyumabad Grid Station for Proposed BQPS-III Power Project	2-13

### 3.0 INSTITUTIONAL, LEGISLATION AND POLICY FRAMEWORK

3.1	GENERAL OUTLINE AND SCOPE	3-1
3.2	PROVINCIAL AND NATIONAL ENVIRONMENTAL POLICY, LEGISLATION AND GUIDELINES	3-2
	3.2.1 National Conservation Strategy (NCS)	3-2
	3.2.2 National Environmental Policy 2005	3-3
	3.2.3 National Climate Change Policy, 2011	3-4
	3.2.4 National Power Policy, 2013	3-4
	3.2.5 National Environmental Action Plan-Support program (NEAP-SP)	3-5

3.2.6	Sindh Environmental Protection Act 2014	3-5
3.2.7	Land Acquisition Act, 1894	3-9
3.2.8	Pakistan Penal Code (1860)	3-9
3.2.9	Port Qasim Authority Act, 1973 (Modified in 2002)	3-9
3.2.10	The Antiquities Act	3-10
3.2.11	The Factories Act, 1934	3-10
3.2.12	Electricity Act, 1910	3-10
3.2.13	Sindh Wildlife Protection (Amendment) Act 2008	3-11
3.2.14	Sindh Forest Act (2012)	3-11
3.2.15	The Sindh Fisheries Ordinance, 1980	3-11
3.2.16	Sectoral Guidelines for Thermal Power Stations, 1997	3-11
3.3	NATIONAL AND INTERNATIONAL GUIDELINES OR STANDARDS	3-11
3.3.1	The Pakistan Environmental Assessment Procedures, 1997	3-11
3.3.2	OSHA Standards Health Safety	3-12
3.3.3	World Bank Guidelines on Environment	3-12
3.3.4	World Bank EHS General Guidelines, 2007	3-12

## 4.0 PHYSICAL ENVIRONMENT

4.1	GENERAL OUTLINE AND SCOPE	4-1
4.2	TOPOGRAPHY	4-2
4.3	LAND COVER & LAND USE	4-4
4.4	GEOLOGY	4-7
4.5	CLIMATE	4-7
4.5.1	Water Temperature	4-8
4.5.2	Rainfall	4-9
4.5.3	Relative Humidity	4-10
4.5.4	Wind Speed and Direction	4-11
4.6	AMBIENT AIR AND NOISE QUALITY	4-13
4.6.1	Baseline Data	4-13
4.6.2	Key Observations on Ambient Air Quality	4-24
4.7	WATER RESOURCES	4-24
4.7.1	Surface Water Resources	4-24
4.7.2	Key Observations on Drinking Water Quality	4-26
4.7.3	Groundwater Resources	4-31
4.8	FAULTS, EARTHQUAKES AND SEISMIC HAZARD	4-32
4.9	TSUNAMIS	4-34
4.9.1	Storms and Cyclones	4-35

## 5.0 ECOLOGICAL ENVIRONMENT

5.1	GENERAL OUTLINE AND SCOPE	5-1
5.2	GENERAL HABITATION OF AREA UNDER FOCUS	5-2
5.3	FLORA OF THE PROJECT AREAS	5-5
5.3.1	Survey/Sampling Methodology for Mangroves	5-5
5.3.2	Terrestrial Flora	5-5
5.4	FAUNA OF THE PROJECT AREA	5-10
5.4.1	Survey/Sampling Methodology for Coastal Invertebrate Fauna	5-10
5.4.2	Brief Description and Findings	5-11
5.4.3	Benthic Invertebrate (MBI)	5-18
5.4.4	Survey/Sampling Methodology for Endemic Birds	5-21
5.4.5	Cetaceans	5-21
5.5	CONCLUSION	5-22

## **6.0 SOCIO-ECONOMIC & CULTURAL ENVIRONMENT**

6.1	GENERAL OUTLINE AND SCOPE	6-1
6.2	PROJECT LOCATION AND ADMINISTRATIVE SETUP	6-2
6.3	TRAFFIC INLETS AND OUTLETS	6-4
6.4	DEMOGRAPHICS	6-4
6.5	NETWORKING AND BUSINESS ACTIVITIES	6-10
6.6	LIVELIHOOD	6-10
	6.6.1 The Fishing Communities of the Project Area	6-11
	6.6.2 The Non Fishing Communities of the Project Area	6-11
6.7	LEADERSHIP DYNAMICS	6-12
6.8	EDUCATION	6-12
6.9	HEALTH	6-13
6.10	CULTURE, ETHNICITY AND RELIGION	6-14
6.11	RECREATIONAL AREAS	6-15

## **7.0 STAKEHOLDER CONSULTATION**

7.1	GENERAL OVERVIEW AND SCOPE	7-1
7.2	SCOPING MEETING & STAKEHOLDER CONSULTATION OUTCOMES	7-1
7.3	STAKEHOLDER CONSULTATION OUTCOMES	7-4
	7.3.1 Outcomes, Concerns and Recommendations of Scoping Meeting Participants	7-4
	7.3.2 Outcomes, Concerns and Recommendations of Stakeholder during KIIs	7-7

## **8.0 ANALYSIS OF ALTERNATIVES**

8.1	GENERAL OUTLINE AND SCOPE	8-1
8.2	ANALYSIS OF PROJECT REFUSAL	8-1
	8.2.1 Overview	8-1
	8.2.2 Key Observations	8-1
	8.2.3 Rationale for Project Approval	8-3
8.3	ANALYSIS OF SITE ALTERNATIVES	8-3
	8.3.1 Overview	8-3
	8.3.2 Key Observations	8-3
	8.3.3 Rationale for Site Selection	8-3
8.4	ANALYSIS OF ALTERNATE TECHNOLOGY/DESIGN	8-4
	8.4.1 Overview	8-4
	8.4.2 Combined Cycle Technology	8-4

## **9.0 ENVIRONMENTAL IMPACTS AND MITIGATIONS**

9.1	GENERAL OUTLINE AND SCOPE	9-1
9.2	IMPACT ASSESSMENT METHODOLOGY	9-2
9.3	IMPACT ASSESSMENT (CONSTRUCTION PHASE)	9-3
	9.3.1 Impact on Physical Resources	9-3
	9.3.2 Impact on Environmental Resources	9-4
	9.3.3 Impact on Ecological Resources	9-8
	9.3.4 Impact on Human Environment	9-9
	9.3.5 Socio-Economics	9-10
	9.3.6 Waste Disposal	9-11
9.4	IMPACT ASSESSMENT (OPERATIONAL PHASE)	9-12
	9.4.1 Impact on Physical Resources	9-12



9.4.2	Impact on Environmental Resources	9-12
9.4.3	Impact on Ecological Resources	9-14
9.4.4	Impact on Human Environment	9-16
9.4.5	Socio-Economics	9-17
9.4.6	Waste Disposal	9-17

## **10.0 ENVIRONMENTAL MANAGEMENT AND MONITORING PLAN**

10.1	OVERVIEW AND SCOPE	10-1
10.2	PURPOSE AND OBJECTIVES	10-1

## **11.0 CONCLUSION**

### **ANNEXURE**

- I- ESIA Study Team
- II- SEQS 2015
- III- Sindh Hazardous Substances Rules, 2014
- IV- HSEQ Policy
- V- Traffic Management Plan
- VI- Air Dispersion Modeling Report
- VII- Thermal Plume Modeling Report
- VIII- General Layout of the Proposed Project

# LIST OF EXHIBITS

---

## **Chapter: 1 INTRODUCTION**

Exhibit 1.1:	Natural Gas Demand Projections	1-2
--------------	--------------------------------	-----

## **Chapter: 2 PROJECT DESCRIPTION**

Exhibit 2.1:	Pictorial Presentation of Surveys and Technical Discussion	2-1
Exhibit 2.2:	Proposed Installations for BQPS-III Power Project	2-2
Exhibit 2.3:	2 X 450 RLNG Based Power Generation Units Location Map for BQPS-III Project	2-3
Exhibit 2.4:	01 132 kV GIS Grid Station at KPC for BQPS-III Project	2-4
Exhibit 2.5:	01 132 kV GIS Grid Station at Existing Landhi Grid Station	2-5
Exhibit 2.6:	01 GIS Grid Station at Existing Qayyumabad Grid Station	2-6
Exhibit 2.7:	Proposed installation for 2 X 450 MW R-LNG Based Combined Cycle Power Generation Units 7 & 8	2-7

## **Chapter: 3 INSTITUTIONAL, LEGISLATION AND POLICY FRAMEWORK**

Exhibit 3.1:	Policies, Legislation and Guidelines	3-1
--------------	--------------------------------------	-----

## **Chapter: 4 PHYSICAL ENVIRONMENT**

Exhibit 4.1:	Pictorial Presentation of Baseline Investigations and Observations	4-1
Exhibit 4.2:	Topographic Elevation Map of the Proposed Project Areas	4-3
Exhibit 4.3:	Graphical Representation of Land Cover Pattern of Karachi	4-4
Exhibit 4.4:	Graphical Representation of the Land Cover Pattern of the Proposed Project Area	4-5
Exhibit 4.5:	Land use Pattern in Close Proximity of the Proposed Project Area	4-6
Exhibit 4.6:	Mean Maximum and Minimum Temperature (January 1-1980 to December 31-2016)	4-8
Exhibit 4.7:	Mean Monthly Water Temperature (January 1-1980 to December 31-2016)	4-9
Exhibit 4.8:	Maximum Precipitation (%) (January 1-1980 to December 31-2016)	4-10
Exhibit 4.9:	Average Monthly Rainfall (January 1-1980 to December 31-2016)	4-10
Exhibit 4.10:	Relative Humidity	4-11
Exhibit 4.11:	Average Wind Speed (January 1-1980 to December 31-2016)	4-12
Exhibit 4.12:	Wind Direction over the Entire Year (January 1-1980 to December 31-2016)	4-12
Exhibit 4.13:	Pictorial Profile of Ambient Air Quality and Noise level Monitoring	4-13
Exhibit 4.14:	Ambient Air Monitoring Location Map at Port Qasim for BQPS-III Power Project	4-14
Exhibit 4.15:	Ambient Air Monitoring Location Map at Korangi-KPC for BQPS-III Power Project	4-15
Exhibit 4.16:	Ambient Air Monitoring Location Map at Landhi for BQPS-III Power Project	4-16
Exhibit 4.17:	Ambient Air Monitoring Location Map at Korangi-Qayyumabad for BQPS-III Power Project	4-17

Exhibit 4.18:	Ambient Air Quality and Noise Monitoring Results	4-18
Exhibit 4.19:	Graphical representation of Ambient Air Quality and Noise Monitoring Results at all Monitoring Locations for BQPS-III Power Project	4-20
Exhibit 4.20:	Chemical analysis results of Drinking Water	4-23
Exhibit 4.21:	Microbial Analysis Results of Drinking Water	4-26
Exhibit 4.22:	Pictorial Representation for Sea Water Sampling	4-26
Exhibit 4.23:	Seawater Sampling Points at Port Qasim, for BQPS-III Power Project	4-27
Exhibit 4.24:	Sea Water Analysis Results of samples collected from Intake and Outfall Channel	4-28
Exhibit 4.25:	Graphical Representation of Average Concentrations of Sea Water Analysis	429
Exhibit 4.26:	Deep Sea Wave Data, For the Southwest Monsoon Months (May to September) Applicable To Pakistan Coast	4-30
Exhibit 4.27:	Tectonics Map of Pakistan	4-32
Exhibit 4.28:	Tectonics of Southern Pakistan	4-33
Exhibit 4.29:	Earth quake Density of Pakistan	4-33
Exhibit 4.30:	Seismic Hazard Map of Pakistan	4-34
Exhibit 4.31:	Historical Tsunamis Generated In the Region (Up To 1945)	4-35

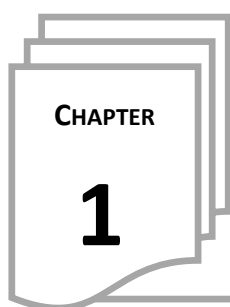
## **Chapter: 5      ECOLOGICAL ENVIRONMENT**

Exhibit 5.1:	Biodiversity Study Area under Focus	5-3
Exhibit 5.2:	Floral and faunal sampling location map	5-4
Exhibit 5.3:	Floral Species Observed in Intertidal and Terrestrial Habitat of PQA	5-6
Exhibit 5.4:	Floral species Observed at Landhi, Korangi and Qayyumabad	5-8
Exhibit 5.5:	Pictorial Profile of Common Floral species observed at PQA, Landhi, Korangi and Qayyumabad	5-9
Exhibit 5.6:	The numbers of organisms observed in per kg of screen debris at BQPS-I intake channel	5-12
Exhibit 5.7:	Descriptive Statistics of faunal community at the sampled location	5-13
Exhibit 5.8:	Pictorial Profile of Epi-pelegic Fauna Observed in the Sampling Area.	5-13
Exhibit 5.9:	The Epifaunal Abundance Observed at the Outfall Channel of BQPS-I	5-15
Exhibit 5.10:	Pictorial Profile of Epi Pelagic Fauna Observed at the Outfall Channel	5-16
Exhibit 5.11:	Descriptive Statistics of individuals observed at 3 locations in the outfall channel	5-17
Exhibit 5.12:	The Epi-faunal species distribution (aggregate or random)	5-17
Exhibit 5.13:	Shannon Weiner biodiversity Index for the outfall channel	5-18
Exhibit 5.14:	Descriptive Statistics of Benthic Fauna Observed In the Sampling Area	5-18
Exhibit 5.15:	Marine benthic Invertebrates observed at the outfall sampling location	5-19
Exhibit 5.16:	MBI observed in the outfall sampling location.	5-20

## **Chapter: 6      SOCIO-ECONOMIC & CULTURAL ENVIRONMENT**

Exhibit 6.1:	Administrative Setup of the Proposed Project Area	6-3
Exhibit 6.2:	North Western Zone Layout of PQA	6-6
Exhibit 6.3:	Southwestern Zone of PQA	6-7
Exhibit 6.4:	Eastern Industrial Zone of PQA	6-8
Exhibit 6.5:	Human Settlement in Project Vicinity	6-9
Exhibit 6.6:	Pictorial Presentation of Fishing Community at Rehri Goath and on Field While Fishing	6-11
Exhibit 6.7:	Educational Facilities of the Proposed Project Area	3-13
Exhibit 6.8:	Health Care Facilities of the Proposed Project Area	6-14
Exhibit 6.9:	Socioeconomic Features of the Bin Qasim Town	6-16

<b>Chapter: 7</b>	<b>STAKEHOLDER CONSULTATION</b>	
Exhibit 7.1:	List of Participants of Stakeholder Consultation Workshop	7-2
Exhibit 7.2:	Pictorial Presentation of Scoping Meeting	7-5
Exhibit 7.3:	Pictorial Presentation of KIs	7-9
<b>Chapter: 8</b>	<b>ANALYSIS OF ALTERNATIVES</b>	
Exhibit 8.1:	Natural Gas Demand Projections	8-2
<b>Chapter: 9</b>	<b>ENVIRONMENTAL IMPACTS AND MITIGATIONS</b>	
Exhibit 9.1:	Anticipated Waste Generation during Operation	9-19
<b>Chapter: 10</b>	<b>ENVIRONMENTAL MANAGEMENT AND MONITORING PLAN</b>	
Exhibit 10.1:	Impact Scaling Criteria	10-2
Exhibit 10.2:	Environmental Management and Monitoring Plan	10-3



# INTRODUCTION

## 1.1 OVERVIEW

<b>Study Type</b>	Environmental and Social Impact Assessment (ESIA).
<b>Study Title</b>	ESIA of BQPS-III 900 MW RLNG Based Combined Cycle Power Project (BQPS-III RLNG CCPP).
<b>Location</b>	Port Qasim, Karachi Pakistan.
<b>Project Proponent</b>	K-Electric.
<b>Project Consultant</b>	Global Environmental Management Services (Pvt) Ltd. (GEMS)

This report discusses the Environmental and Social Impact Assessment (ESIA) of K-Electric, BQPS-III 900 MW RLNG Based Combined Cycle Power Project. The report also analyzes the impacts associated with the construction and operational phase of the proposed project and its surroundings, suggest mitigation measures, and identify residual impact which needs monitoring.

## 1.2 PROJECT BACKGROUND

Karachi is the industrial, financial and trading hub of Pakistan. The availability of port facilities has attracted energy related investments over several decades thus positioning Karachi as the focal point of the energy corridor of Pakistan. However K-Electric commonly referred to as KE is a vertically integrated electric company involved in generating, transmitting and distributing power recorded a peak demand of 2565 in 2010 and increased by nearly 735 MW in Last 7 years. <sup>1</sup> Moreover it is important to note that K-Electric has its own generation capacity of 2,267dee MW, predominantly from its major Thermal Power Plants (Bin Qasim Power Station (BQPS)-I, II and Korangi Power Complex (KPC) and two Gas Engines Power Plants (SITE & Korangi), inclusive of 450 MW that has been added owing to the initiatives of the new management and the company inaugurated an additional 560 MW project in 2012. While on the other hand it is important to note that existing power station namely BQPS-I at Port Qasim is one of the oldest power station of K-Electric which is currently running on dual fuel i.e. Natural Gas (NG) and Heavy Furnace Oil (HFO). The existing power generation units Insufficient to cater the power generation needs of the city. While, the current demand for electricity is increasing

<sup>1</sup> Environmental & Social Impact Assessment of 250 MW Dual Fuel Power Plant KPC-II Karachi Sindh

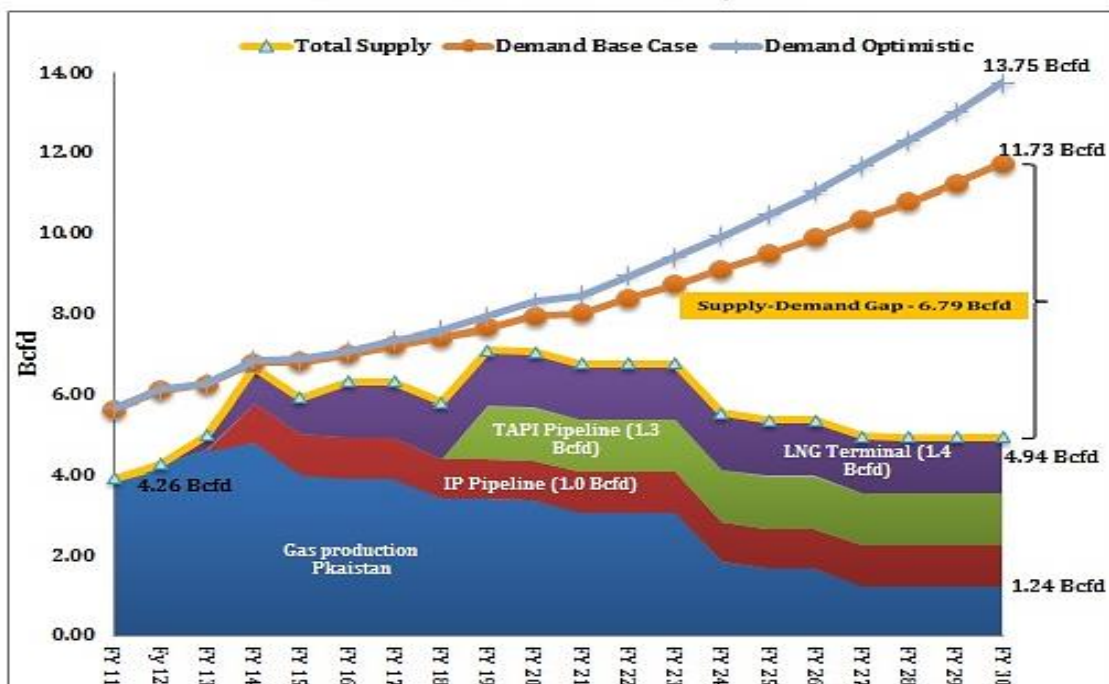
with the passage of time. To meet the shortfalls of electricity and to enhance the efficiency by reducing the demand-supply gap for the power consumers, KE has decided to install the Re-gasified Liquefied Natural Gas (RLNG) based 2 X 450 MW Combined Cycle Power Generation Units which will replace existing 2 x 210 MW unit 3 & 4 within the existing premises of BQPS-I along with new 132kv GIS at Korangi west and Qayyumabad grids and the project will be titled as BQPS-III project. The detailed description of installation and modification at different grid stations has been discussed in the chapter 2 of this ESIA report.

### 1.3 NEED ASSESSMENT

Pakistan is in the midst of a severe energy crisis that largely stemmed from mismanagement of natural resources in the country. Weak regulatory and pricing mechanisms in the natural gas sector have led to huge disparities between demand and supply. Pakistan has a large demand for natural gas and a well-established gas market and distribution system. At present, demand of natural gas is estimated at around 8 Billion Cubic Feet (BCF) against a total supply of 4 BCF, creating a shortfall of 4 BCF.<sup>2</sup>

As per Pakistan Gas Supply-Demand Study conducted in 2012 by ILF Beratendelngenieure GmbH, over the next 17 years gas demand is projected to stand at 11.73 BCFD, while domestic supplies are expected to reach the level of 4.94 BCFD resulting in a huge shortfall of about 6.79 BCFD by FY 2030. The analysis was done considering the existing and planned capacity. Below given Exhibit shows the yearly natural gas supply-demand project. A base case scenario is considered based on existing scenario i.e. business as usual.

**Exhibit 1.1:** Natural Gas Demand Projections



Source: ILF Report on Gas/ Supply Demand Analysis and Base Gas Demand 2012

<sup>2</sup> Total Gas Demand on System, 2013. Internal Documents of Ministry of Petroleum and Natural Resources. Islamabad, Pakistan

In order to meet the future energy challenges, to sustain and support economic growth, to mitigate the impact of widening shortfall, the Government has encouraged private investment LNG sector to establish an LNG Import projects under the LNG Policy 2002, 2006 & 2011.

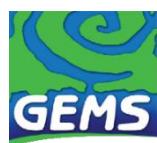
The Government of Pakistan has decided to place heavy reliance on LNG Imports and has projected a market potential of 30 MTPA which is targeted to be achieved by 2020. Based on the above stated facts and figures KE being one of the sensible custodian of Environment has also decided to place their reliance on imported LNG and initially replace their existing 2 x 220 MW NG and HFO based power generation units of BQPS-I by adding 2 X 450 MW RLNG based power generation units within the existing premises of BQPS-I. The proposed project aims to reduce environmental pollution while enhancing the system efficiency and power generation capacity in order to meet future energy challenges.

## 1.4 PROPONENT'S PROFILE



K-Electric, commonly referred to as KE is a vertically integrated electric company involved in generating, transmitting and distributing power to over 2.5 million customers in Karachi and in the nearby towns of Dhabeji and Gharo in Sindh, and Hub, Uthal, Vinder and Bela in Balochistan. It employs over 10,000 people and covers 6,500 square kilometers with industrial, commercial, agricultural and residential areas falling under its network. K-Electric has its own generation capacity of 2,276 MW, predominantly from its major Thermal Power Plants (BQPS I, BQPS II and KPC) and two Gas Engines Power Plants (SITE & Korangi), inclusive of 450 MW that has been added owing to the initiatives of the new management and the company inaugurated an additional 560 MW project in 2012. K-Electric being a prestigious and environmentally conscious organization wants to comply with all applicable laws and therefore intends to carry out the environmental impact assessment of its new Power Plant Project in Karachi.

## 1.5 CONSULTANT'S PROFILE



Global Environmental Management Services (Pvt.) Ltd. (GEMS) is an Environmental Consultancy which provides broad range of Environmental Solutions which are and not limited to Environmental Audits, Initial Environmental Examinations (IEE), Environmental Impact Assessments (EIA), Baseline studies and Training & Capacity building. GEMS is one of the few environmental firm having its own renowned ISO 17025 Certified Environmental Laboratory by the name of Global Environmental Laboratory (Pvt) Ltd.

GEMS have several divisions at work which provides core quality services. They are as follows:

### 1.5.1 Consultancy Division:

GEMS offer the following services to various industries, government institutions and international development organizations:

- Environmental impact assessments

- Environmental audits and management plans
- Baseline studies and habitat mapping
- Capacity building and trainings
- Cleaner production for industries

### **1.5.2 Laboratory Division:**

GEMS Laboratory, Global Environmental Lab (Pvt.) Ltd. is the leading source of environmental solutions. It is providing 24 hours sampling and monitoring services to various sectors including:

- Liquid Effluent Analysis
- Drinking Water Analysis
- Soil and Sludge Analysis
- Microbiological Analysis
- Gaseous Emissions and Particulate Matter Analysis
- Ambient Air Monitoring
- Noise Level Measurements
- Light Intensity Measurements
- Complete Monitoring as per NEQS and SEQs

### **1.5.3 Waste Management Division**

Waste Management Division has the following services:

- Incineration
- Bio-remediation
- Research and Division facility for disposal
- Waste minimization
- Waste recycling
- Integrated Waste Management

For over a decade GEMS have conducted ESIA's in an expanding range of Energy sector (oil and gas industry, power plants etc), Manufacturing industries (e.g. pharmaceutical, mineral fertilizers, textile, paper, food processing etc.), Infrastructure projects (roads, highway's buildings etc.), ports and harbors, tourism, aquaculture and fisheries.



## 1.6 ESIA STUDY TEAM

GEMS personnel have professional environmental and social experience extending throughout Pakistan and UAE. They are all qualified environmental and social scientists with complementary multi-disciplinary skills covering all major biomes of the environment. As a result GEMS is able to offer accurate, independent and appropriate services to its clients and to regulatory bodies.

The ESIA study team profile for the proposed project has been attached as **Annexure I** of the report.

## 1.7 LEGISLATIVE REQUIREMENT

The ESIA of the proposed Project activity will be subjected to the pertinent legislative and regulatory requirements of the Government of Sindh including State laws. Legislation presents a synopsis of environmental policies, legislation and other guidelines that have relevance to the proposed project.

The proposed project falls under the project category of **Schedule II, Category A Energy** “Thermal power generation over 100MW” as per Sindh Environmental Protection Agency Review of Initial Environmental Examination and Environmental Impact Assessment Regulations, 2014. According to these guidelines, project under this category require an ESIA to be conducted at planning stage.

The two primary deliberations of the Act are the conduct of projects only after approval of ESIA from the SEPA and adherence with Sindh Environmental Quality Standards (SEQS).

**It is stated under section 17 of SEPA 2014:**

*“No proponent of a project shall commence construction or operation unless he has filed with the EPA an IEE or EIA, and has obtained from the EPA approval in respect thereof”.*

## 1.8 PURPOSE OF THE STUDY

The purpose of this ESIA study is to evaluate the significant Environmental and Social aspects of the proposed project and identify requirements and standards that need to be complied specifically with SEPA Regulations, 2014.

The specific objectives of this ESIA are to:

1. Identify the relevant stakeholders that need to be consulted to evaluate Environmental and Social aspects of the project.
2. Assess the existing environmental conditions in the proposed project area, including identification of environmentally sensitive areas and significant receptors;
3. Assess various project related activities to identify potential impacts on environment and social baseline settings and determine their significance;

4. Propose appropriate mitigation measures that can be incorporated into the project design, commissioning and operating phases to minimize damaging effects or lasting negative consequences identified by the environmental assessment;
5. Assess the proposed activities and ensure their compliance with the relevant environmental regulations of the province;
6. Prepare an ESIA report for submission to the SEPA in compliance with SEPA Review of IEE and EIA Regulations 2014.

## 1.9 SCOPE OF THE ESIA

For the ESIA study, the scope of work is as under:

1. Description of physical, environmental, socio-economic and cultural setting and baseline conditions in the proposed project area;
2. Identification and prediction of proposed project impacts and their significance relating to the proposed project activities;
3. Identification and assessment of the applicability and effectiveness of mitigation measures to offset or minimize adverse impacts on environment.

## 1.10 APPROACH AND METHODOLOGY

The ESIA was performed in five main phases, which are described below.

### 1.10.1 Scoping

The key activities of this phase included:

**Project Data Compilation:** A generic description of the proposed project (i.e. construction and operation), within the proposed project area relevant to environmental assessment, was compiled with the help of PEPA Guidelines and proponent i.e. KE.

**Literature Review:** Secondary data and information related to weather, soil, water resources, coastal and marine ecology, and wildlife was reviewed and compiled.

**Legislative Review:** Information on relevant legislation, regulations, guidelines, and standards was reviewed and compiled.

**Key Stakeholder Identification:** Key stakeholders, including primary and secondary, were identified that were directly and indirectly related with the proposed project. Their concerns were recorded and documented.

**Identification of Potential Impacts:** The information collected in the previous steps was reviewed, and potential environmental issues were identified.

### 1.10.2 Baseline Studies

Following the scoping exercise, the proposed project area was surveyed to collect primary data. During the field visits, information was collected on ecologically important areas, ambient air quality, surface and groundwater resources, existing infrastructure, local communities and public services. The following specific studies were conducted as part of the ESIA.

**Ecological Baseline:** Biological experts conducted an ecological baseline study, which consisted of a thorough literature review and field data collection. During the fieldwork, the faunal species of the area were documented. The diversity of avian, large and small mammals, and reptile species were determined. Information was collected on the species found in approximately 3 km radius of the area.

Floral species of the area were also identified through fieldwork and literature review.

**Physical Environment:** Environmental Assessment Specialists conducted physical environmental study including, ambient air, noise, water sampling, surface water resources and the groundwater resources of the areas. Specialists also carried out the impact of proposed project on soil and water resources.

**Socioeconomic Study:** Sociologist conducted socioeconomic and cultural study in the proposed project area. The study team through participatory techniques collected data from the locals of the proposed project area as well as the local governing bodies. The profile included livelihood, culture, leadership, gender issues, spiritual and temporal leadership, demographic information based on field data and published sources, the existing use of land resources, community structure, employment, distribution of income, goods and services, public health, local religious and cultural values, and local customs, aspirations, and attitudes.

### 1.10.3 Impact Assessment

The environmental, socioeconomic, cultural, gender and project information collected in previous phases were used to assess the potential impacts of the proposed activities. The issues studied included potential project impacts on:

- Ambient air quality;
- Ecology of the area, including flora and fauna;
- Local communities;
- Water quality.

Wherever possible and applicable, the report discusses the following aspects:

- The present baseline conditions;
- The change in environmental parameters likely to be affected by proposed project related activities;
- Identification of potential impacts;

- Likelihood and significance of potential impacts;
- Mitigation measures to reduce impacts to negligible level;
- Prediction of impacts, including all long-term and short-term, direct and indirect, and beneficial and adverse impacts;
- Evaluation of the importance or significance of impacts (The significance of each impact has been judged on the basis of available local, national, and international standards. Where such standards were not available, the best practice elsewhere has been referred to);
- Implementation of mitigation measures (i.e., environmental management);
- Determination of residual impacts;
- Identification of controls and monitoring of residual impacts.

#### **1.10.4 Documentation**

At the end of the assessment, a report is prepared according to the relevant guidelines of SEPA. This report includes the findings of the assessment, proposed project impacts, and mitigation measures to be implemented during the execution of the proposed activities.

The standard report format is as follows:

- Executive Summary
- Introduction
- Project Description & impact areas
- Institutional, Legislation and Policy Framework
- Physical Environment
- Ecological Environment
- Socio-Economic and Cultural Environment
- Alternatives
- Environmental Impacts and Mitigations
- Environmental Management and Monitoring Plan
- Conclusion

CHAPTER  
**2**

# PROJECT DESCRIPTION

## 2.1 GENERAL OUTLINE AND SCOPE

This section of the ESIA report presents a detailed technical description of the proposed project. A detailed insight regarding the proposed project was established by reconnaissance survey, site visit, and detailed discussions between technical teams of K-Electric and GEMS (refer **Exhibit 2.1** for pictorial presentation of surveys and technical discussions).

**Exhibit 2.1:** Pictorial Presentation of Surveys and Technical Discussion



### Key Features of Proposed Power Project

<b>Proposed Installations</b>	2 X 450 MW Power Generation Units 03 132 kV GIS & 01 220 kV GIS
<b>Power Plant Technology</b>	Combined Cycle
<b>Project Life</b>	30 Years
<b>Fuel Type</b>	RLNG/Natural Gas
<b>Annual Fuel Consumption</b>	90996~126384 Nm <sup>3</sup> /a
<b>Gross Thermal Efficiency</b>	59 %
<b>Cooling Water Requirement</b>	2 x 34,811.44 m <sup>3</sup> /h

### Key Benefits of the Proposed Power Project

- Enhanced power capacity
- Efficient power generation
- Reduces emissions
- Greater operational flexibility

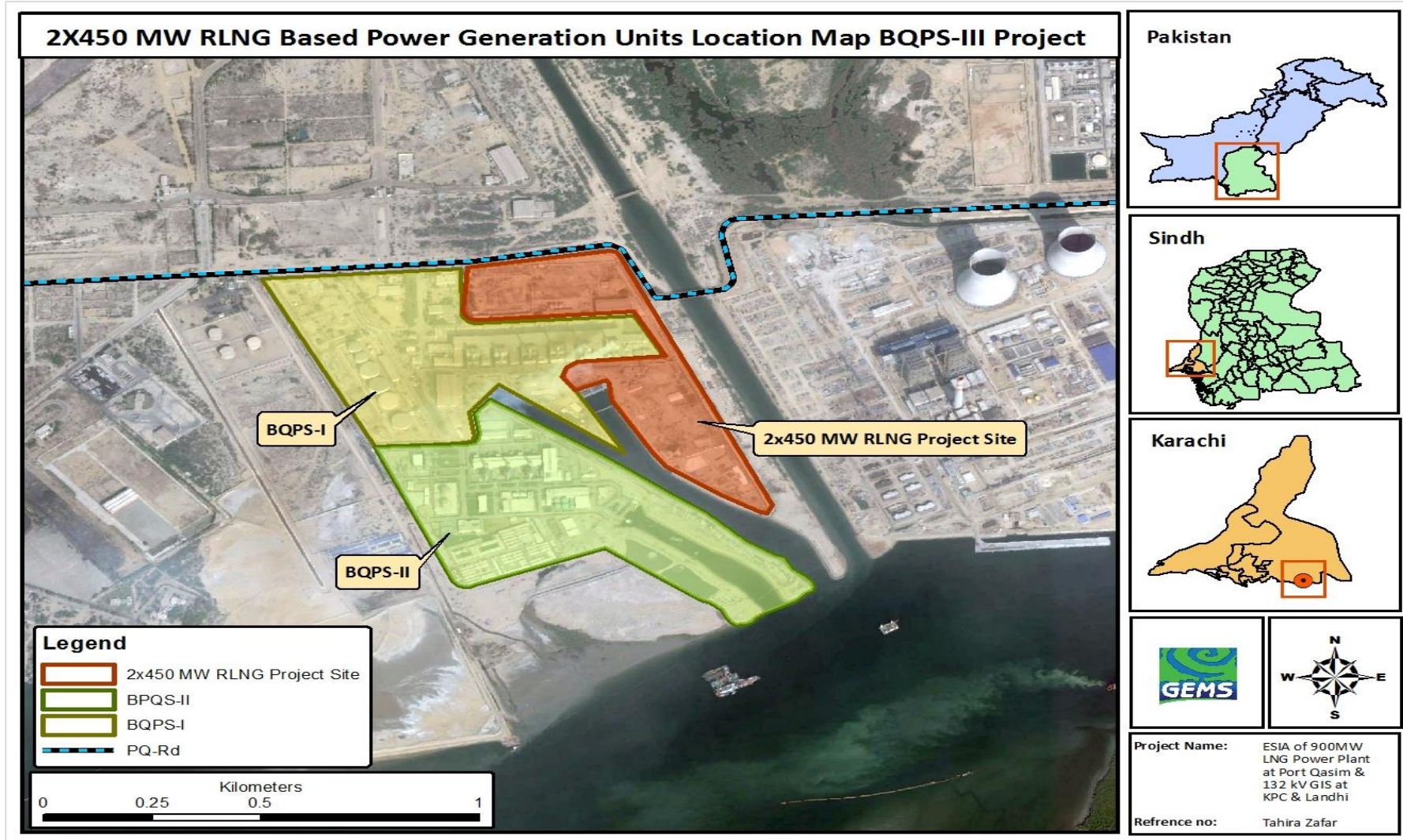
## 2.2 PROPOSED PROJECT LOCATION

The proposed project mainly deals with 02 X 450 MW RLNG Based Combined Cycle Power Generation Units. It also includes installation of mechanical structures for power generation units at Port Qasim and at two Grid Stations and two Substation. Proposed installations for BQPS-III power project are presented below as **Exhibit 2.2**.

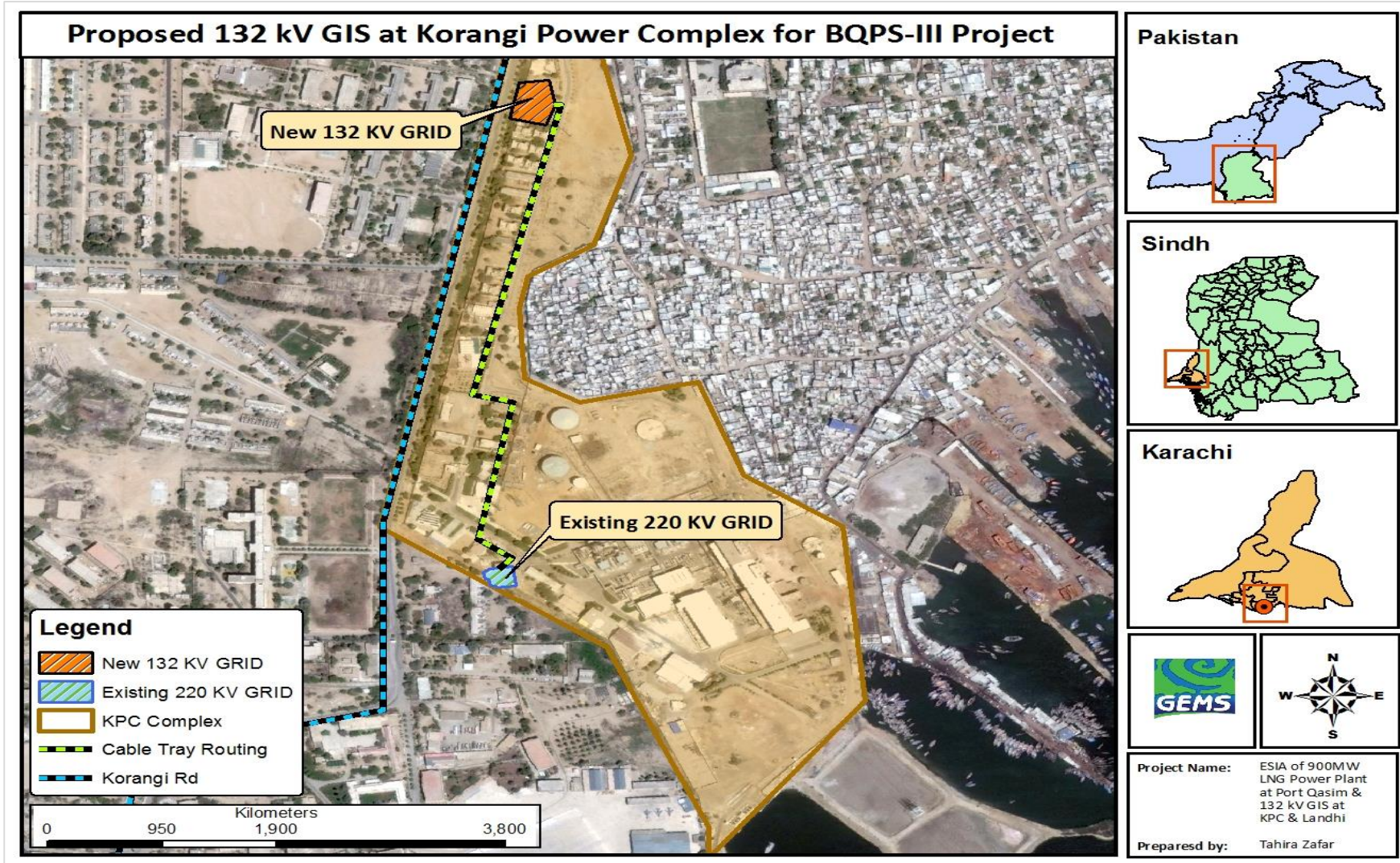
**Exhibit 2.2:** Proposed Installations for BQPS-III Power Project:

<b>Proposed Installations</b>	<b>Location</b>	<b>Attachments</b>
02 X 450 MW of RLNG Based Power Generation Unit	BQPS-I	Exhibit 2.3
01 X 220 kV GIS Grid Station	BQPS-I	
<b>01 X 220 kV ICI Switch Station</b>	Opposite BQPS-I	
01 X 132 kV GIS Grid Station	KPC	Exhibit 2.4
01 X 132 kV GIS Substation	Landhi Grid Station	Exhibit 2.5
01 X 132 kV GIS Substation	Korangi West and Qayyumabad	Exhibit 2.6

**Exhibit 2.3:** 2 X 450 RLNG Based Power Generation Units Location Map for BQPS-III Project

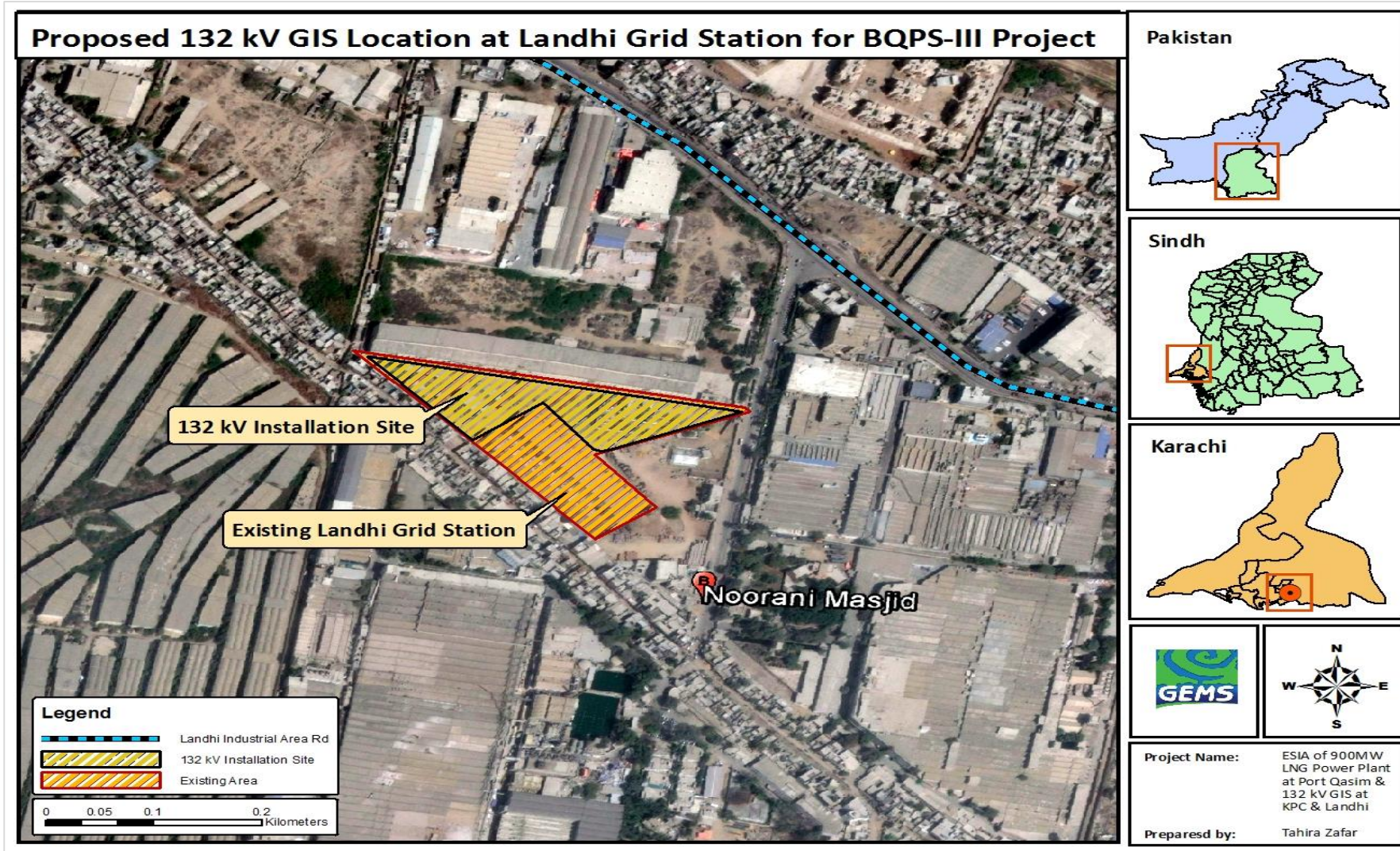


**Exhibit 2.4:** 01 132 kV GIS Grid Station at KPC for BQPS-III Project

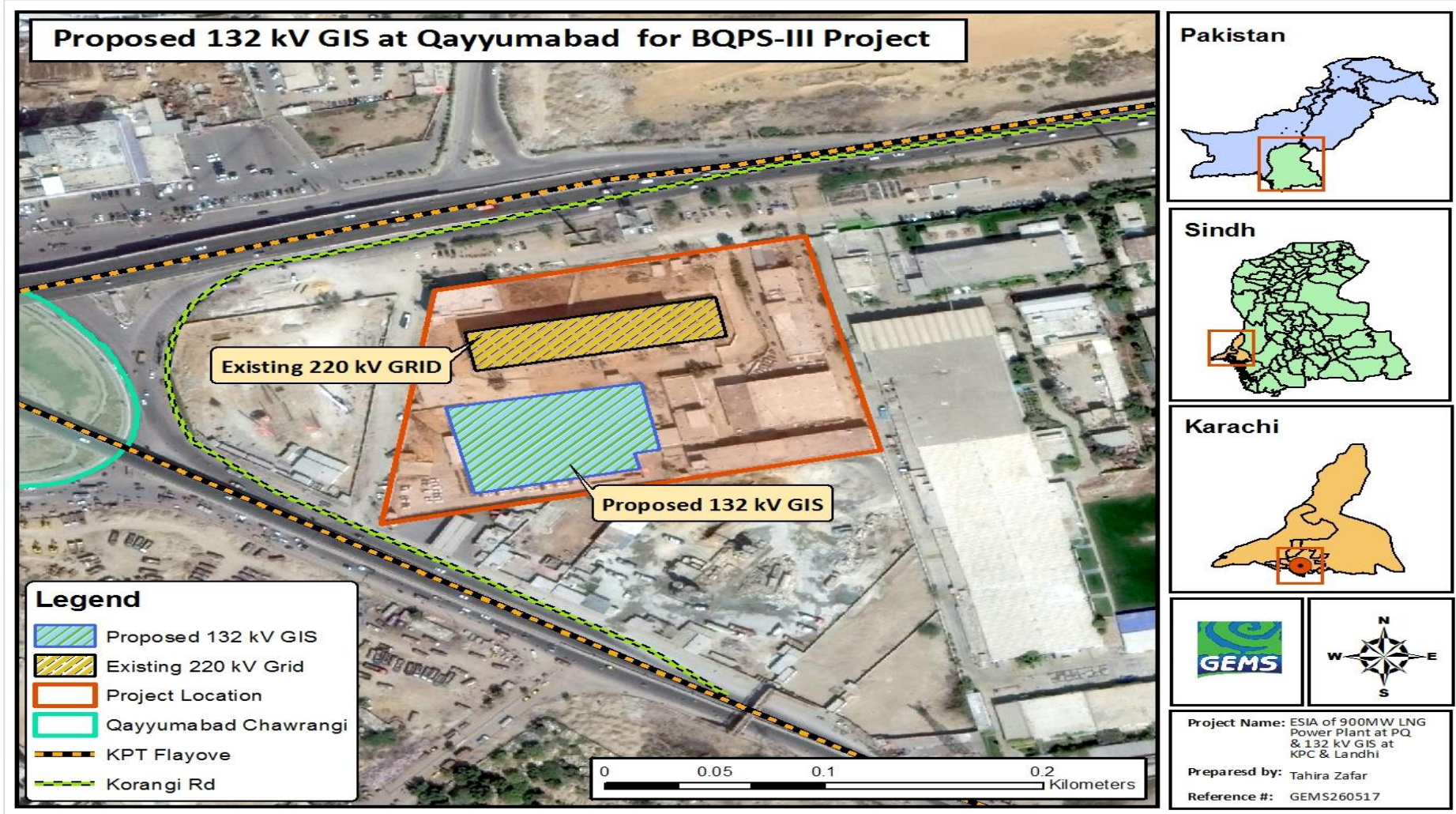




**Exhibit 2.5:** 01 132 kV GIS Grid Station at Existing Landhi Grid Station



**Exhibit 2.6:** 01 GIS Grid Station at Existing Qayyumabad Grid Station



## 2.3 TECHNICAL DESCRIPTION

The proposed project needs a number of installations, detailed description of the installations for BQPS-III Power Project are defined as under:

### 2.3.1 Installations within the Existing Premises of BQPS-I for Proposed BQPS-III Power Project:

The proposed project includes construction of 02 X 450 R-LNG sets of 1+1+1 configuration Gas Turbine F class combined-cycle power generation units namely unit 7 & 8 inside the boundary of BQPS-I which will replace existing unit 3 and 4. These units are NG and HFO based power generation units of BQPS-I. Proposed installation for 2 X 450 MW R-LNG Based Combined Cycle Power Generation Units 7 & 8 are presented below as **Exhibit 2.7**.

**Exhibit 2.7:** Proposed installation for 2 X 450 MW R-LNG Based Combined Cycle Power Generation Units 7 & 8

Proposed Installation	Specifications
Gas Turbine House	Proposed installation specifications are defined on the next page of this section of ESIA document under heading 2.3.1.1 till 2.3.1.9
Heat Recovery Steam Generators (HRSG)	
Steam Turbine	
Bypass Stacks	
Gas Insulated Switchgear (GIS)	
<b>ICI 220 kV Swith Station</b>	
Gas Boosting and Regulating Station	
Generators and Transformers	
Cooling Water System	
Centralized Control Room (CCR)	
<b>Hydrogen Generation System</b>	
Water Treatment Plant	
Workshop and Laboratories	
Fire Fighting System	

### 2.3.1.1 Gas Turbine House

The gas turbine house will be constructed within the existing premises of BQPS-I. The gas turbines will be arranged indoors and the waste heat boiler will be arranged in the open air. The gas turbine building will be equipped with a ventilation system of natural air inlet through the electric-drive blinds and mechanical exhaust by the explosion-proof roof fan, the ventilation system will also be used for emergency ventilation. Exhaust from the exhaust housing, gas turbine casing and HP/MP casing will be directed outdoors.



Figure 1: Schematic of a Typical Gas Turbine House

A standby exhaust fan will be installed in Gas Turbine House. The ventilation systems of the exhaust housing, gas turbine casing and HP/MP casing will be designed and supplied by the manufacturer of the related equipment. In order to prevent accumulation of hydrogen and natural gas, the natural vent cap will be arranged at the highest point on the roof of the gas turbine building. The roof fan will be of an explosion-proof type. Local jet fans will be arranged at the points with possible process leakage and the dead corners of ventilation so that local accumulation of explosive gas and heat can be avoided. All the HVAC equipment to be placed in hazardous areas will be of an explosion-proof type. (Refer figure 1 to observe a typical gas turbine house)



Figure 2: F Class Gas Turbine

### 2.3.1.2 Heat Recovery Steam Generators (HRSG)

HRSGs will be provided for exhaust gases of RLNG/NG for heating and producing steam. Steam generated in an HRSG from the gas turbine exhaust will be used to supply steam to steam turbine and the fuel heating system.

The HRSG will be of a proven robust horizontal design, requiring minimal maintenance and suitable for the full range of operational flue gas temperatures and

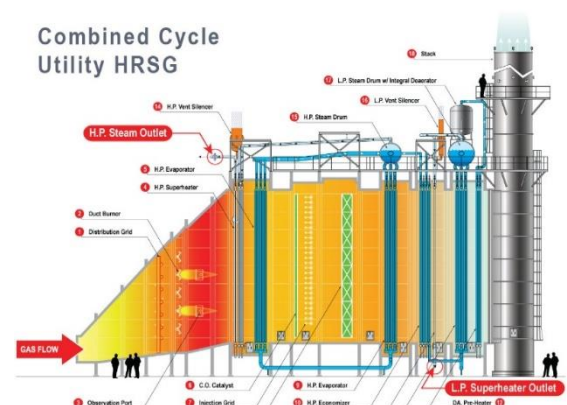


Figure 3: Schematic Representation of a Typical HRSG

profiles. The effect of differential expansion between system components, caused by cooling and heating rates during static and transient operating conditions, will be taken into account in the design. The HRSG design will ensure that no parts suffer from fatigue failure under the range of operating conditions. **Figure 3** is the schematic representation of a typical HRSG system.

The HRSG design is based on the followings essential criteria

- Conformity with the particular requirements of the engine exhausts characteristics;
- Suitability for fast changing in working conditions;
- Long life and reliability to ensure high plant availability;
- Modular design based on factory built modules with as much equipment as practicable factory assembled;
- Easy access for inspection and maintenance;
- Protection of relevant HRSG components from attack by acidic condensation.

### 2.3.1.3 Steam Turbine

The steam turbine sends its energy to the generator drive shaft, where it is converted into additional electricity. In the multiple shaft arrangement, the steam turbine will be connected only with the water conduit with steam on the waste heat boiler equipped for the gas turbine. In the gas-steam combined cycle system, the exhaust from the gas turbine will be sent to the waste heat boiler and bring about water steam; and the high pressure steam from the waste heat boiler will go into the steam turbine to work. (Refer figure 3 for Combined Cycle Turbine System)

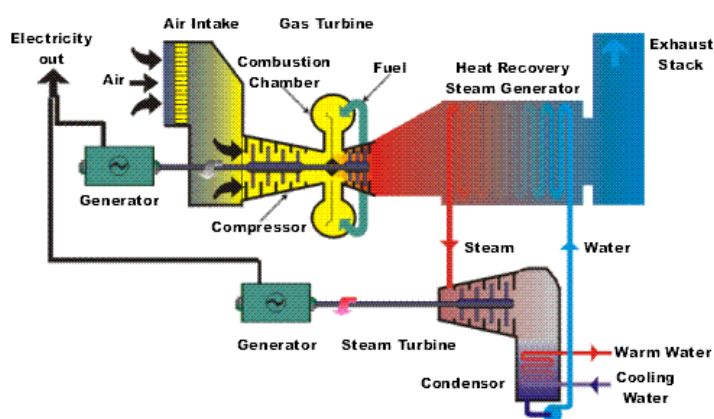


Figure 4: Combined Cycle Turbine System

### 2.3.1.4 Bypass Stacks

Two bypass stacks of 45 m height will be installed for the proposed project, a typical gas turbine bypass system is designed to divert the flue gases from the HRSG to a bypass stack with a silencer assembly to allow the plant to operate in simple cycle mode. This allows the HRSG to be inspected, repaired, or have maintenance performed while it is isolated completely from the gas turbine. Using a bypass stack also allows for combined cycle operation during the day and



Figure 5: Schematic of a Typical Bypass Stack

simple cycle operation at night when power demand is lowest, providing a greater savings in operation cost and efficiency over the life of the power plant. The bypass stack permits power to be generated by the gas turbine even when the steam turbine cycle is down for a scheduled or unscheduled shut down, keeping the plant functional and avoiding potential power outages. (Refer figure 4 to observe a typical bypass stack).

### 2.3.1.5 Gas Insulated Switchgear (GIS)

Generally a GIS is much more reliable, compact and maintenance free. Because of compactness of equipment, a very small area of land and civil work is required resulting in substantial savings. They are at present mostly used in space constraint areas. SF6 Sulfur hexa fluoride gas is being extensively used as a dielectric and extinguishing arc media in the area of high voltage electrical switchgear. Each individual item of switchgear is metal enclosed which is at earth potential. Figure 5 is the schematic representation of a typical GIS system.

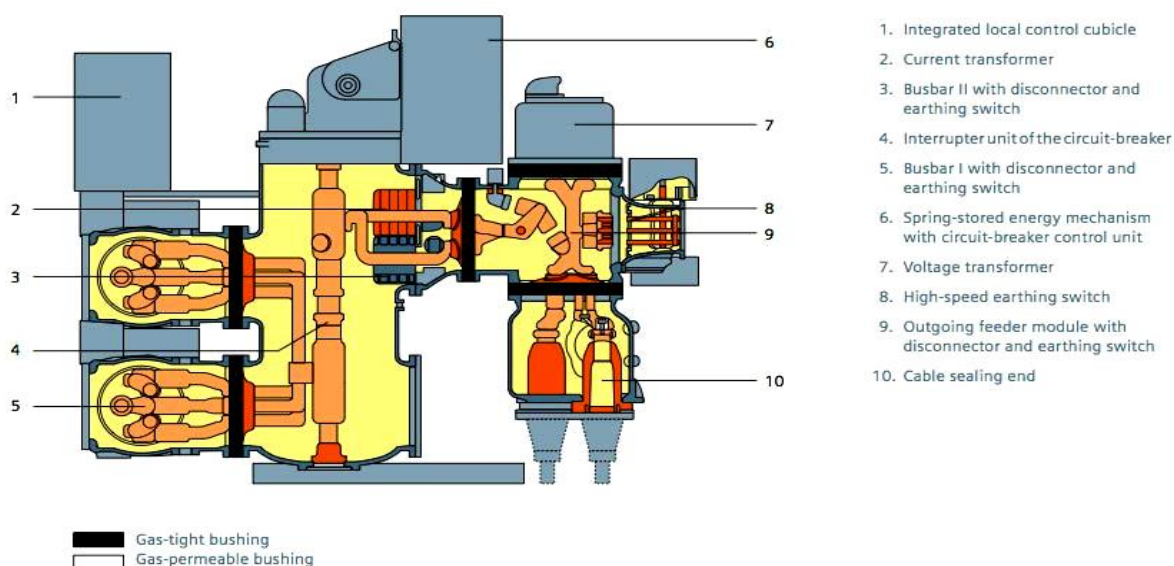


Figure 6: Schematic Representation of a Typical GIS

#### 2.3.1.5.1 Specifications of Proposed 220 kV GIS substation within the Existing Premises of BQPS-I for Proposed BQPS-III Power Project:

As far as proposed project installations area is concerned, a new 220 kV GIS substation will be installed and Four (04) generators will be connected to this new 220kV substation via four unit step-up transformers. The new GIS bus bar will be double bus with two bus section CBs and two bus coupler CBs. The original 4 outgoing overhead lines in BQPS-I GIS will be used as the outgoing lines of the new GIS and for incoming lines there will be two 9F gas turbine unit step-up transformers and unit auxiliary transformers, two 9F steam turbine unit step-up transformers, one new middle-voltage standby transformer, G1, G2, G5, G6 unit step-up transformers and startup transformers.

### Existing Incoming and Outgoing Lines Connection with Proposed 220 kV GIS substation.

2 short link lines of BQPS-I GIS connected to BQPS-II GIS, will be transferred to the new GIS, and two series reactors will be set between new GIS switchyard and BQPS-II GIS switchyard. All incoming lines of the new GIS will use 220 kV cable. 4 outgoing lines will be connected to the overhead lines in BQPS-1 GIS using 220 kV cable.

#### 2.3.1.6 ICI 220 kV Switch Station

The existing ICI 220 kV Switch Station is located opposite to the BQPS-I Power Plant, as the BQPS-III power plant will come into operation, the short circuit current of 220 kV ICI Switching Station will exceed from 40 kA. At present, ICI Switching Station uses single-bus segmented wiring and five (05) loops of incoming and outgoing lines. (Refer Figure 6 for the main electrical connections)

In this proposed activity, five (05) sets of 40 kA AIS equipment including circuit breakers will be replaced by rated current 3150 A and 50 kA short circuit current equipment and the length of cable will be about 2, protection relays and measuring control devices will remain unchanged.

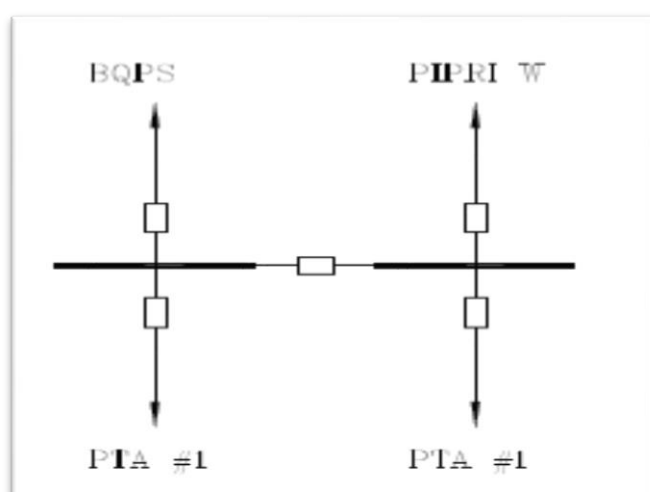


Figure 7: Main Electrical Connections

#### 2.3.1.7 Gas Boosting and Regulating Station

The function of the boosting and pressure regulating station is to regulate the pressure of the natural gas and keep it in the range of the inlet pressure accepted by the gas turbine. It shall be kept stable as well, for it fluctuates with the natural gas consumption along the pipeline. Therefore, a pressure regulating station shall be arranged in the plant area so that the natural gas going into the gas turbine will be kept at a stable pressure.

For the project in question, a set of boost station and a set of pressure regulating station will be arranged for two gas turbines. The pressure regulating station will be equipped with two main pressure regulating pipelines, on which the main and auxiliary pressure regulators, emergency shutoff valve and isolation valve will be installed. Accompanied by a bypass pressure regulating pipeline with the same capacity, each main pressure regulating pipeline will correspond to a gas turbine. The two

main pipelines will not serve as a standby for each other. Each pressure regulating station will be equipped with two filters of 100% capacity and dewatering equipment, with one in operation and the other standby. And Flow meter, Gas Chromatograph and Gas Heater are in the gas treatment station.

The boost station and pressure regulating station can be arranged in three ways: outdoor arrangement; semi-outdoor arrangement with a rain hood; indoor arrangement. The semi-outdoor arrangement with a rain hood is recommended for the project in question.

SSGC are providing gas to both existing BQPS phase I and II through pipeline. Currently SSGC pipe has been laid to the northwest of the project. Pipeline design parameters are 12bar, DN750. The pressure at SSGC natural gas source for the project in question is rather low (about 1.8 bar to 4.5 bar). Natural gas from SSGC will be pressurized in boosting station using Natural Gas Compressor to the level accepted by the gas turbine prior to utilization.

Due to lack of gas, SSGC pipeline can only meet the gas consumption of one F-class gas turbine. Therefore RLNG will be used as alternative. RLNG provider shall delivered the RLNG up to Battery limit through pipeline from where it brought to Gas Condition Station. Then send to the pressure regulating station by pipeline, and transported to the two F class gas turbine. At the same time, SSGC switch to the standby gas source. The gas turbine can transfer gas source from RLNG to SSGC online.

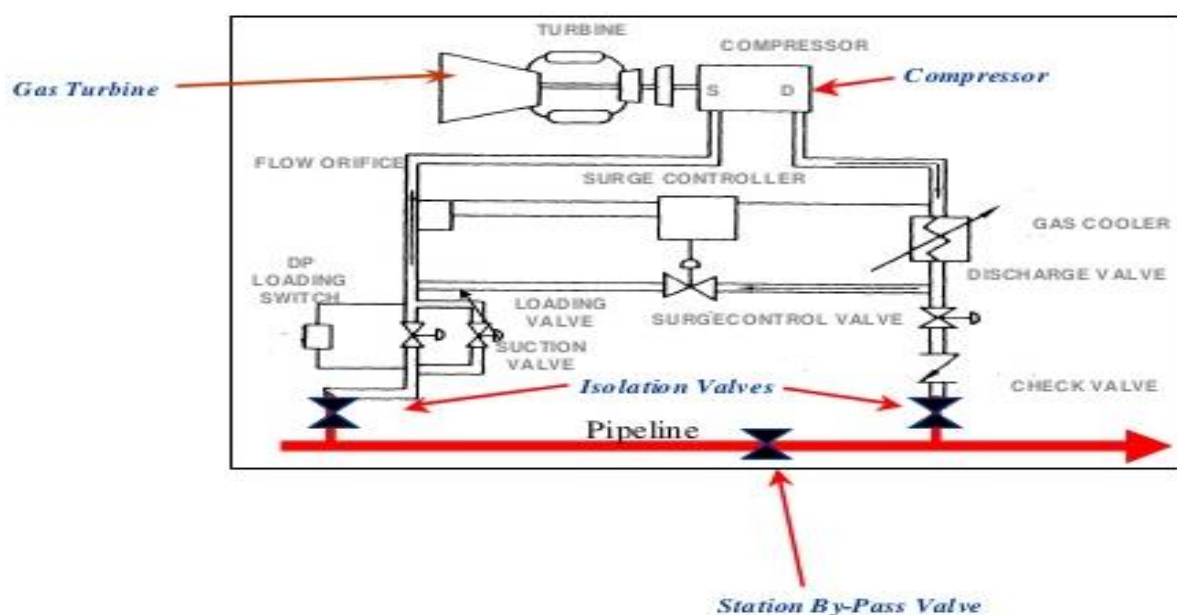


Figure 8: Schematic for Typical Gas Compressor Station

### 2.3.1.8 Generators and Transformers

In the proposed project, two fuel-steam combined cycle units will be constructed. Two gas turbine generators and two condensing engine generators will be connected to the low voltage side of unit step-up transformer (UT) via continuous isolated phase bus. Generator circuit breaker (GCB) will be equipped at outgoing of the gas turbine generator (GTG). The Gas Turbine Generator (GTG) will be full-hydrogen or water-hydrogen-hydrogen cooling. The rated power is temporarily determined as



300MW and the rated power factor is 0.85. The static excitation will be adopted. The Steam Turbine Generator (STG) will be air cooling. The rated power is temporarily determined as 150MW and the rated power factor is 0.85. Self-powered and static excitation will be adopted.

### 2.3.1.9 Cooling System

In this proposed project, once-through cooling system will be adopted. The existing water channel and CW pump facilities of decommissioned units (unit 3 & 4) of BQPS-I will be used for the proposed 7 & 8 unit.

The existing plant has six (06) 210MW gas turbine units and all circulating water systems adopt once-through cooling water supply systems. The water supply source is taken from open channel. Owing to restricted site condition, it is unable to establish new water intake facilities. Both No.3 and No.4 units are respectively equipped with two main circulating water pumps and one auxiliary cooling water pump.

Main cooling water consumption required by two grade F gas turbine is  $2 \times 34,811 \text{ m}^3/\text{h}$  and auxiliary cooling water consumption is  $2 \times 2,500 \text{ m}^3/\text{h}$ . Portable and raw water required in the new plant will come from the existing network of the old plant. The water quantity for the new plant is  $55 \text{ m}^3/\text{h}$ .

The project adopts once-through cooling water supply and main cooling water consumption required by 02 X 450 MW CCPGU is about  $2 \times 26195 \text{ m}^3/\text{h}$

Length of intake channel is about 930 m

Length of outfall channel is about 2187 m

Existing usage is 36,000  $\text{m}^3/\text{hr}$ .

Requirement of new plants is approx. 2 x 34811.44  $\text{m}^3/\text{hr}$

### 2.3.1.10 Centralized Control Room (CCR)

Combined cycle generating units will be monitored and controlled in the centralized control room and control will be conducted in a unit-wise centralized manner. CCR and Electrical Control Room (ECR) will be situated in between the two gas turbines. The gas-steam combined cycle generating units will be controlled with Distributed Control System (DCS). Operator station of the HRSG, Generators and power for each set of the generating units will be placed here. The CCR will be equipped with emergency, start and shutdown buttons so that safe shutdown of the generating units can be ensured in case a failure occurs in the DCS. Circulating water dosing system and water-steam sampling system will be scheduled to be monitored and controlled in the control room of the demineralization system. Moreover, the CCR will also be equipped with the closed-circuit TV monitoring system for the generating units and the plant area making it convenient for the

#### Key Features of Centralized Control Room (CCR)

- Electrical equipment room
- Instrumentation equipment room
- Control system
- Firefighting system
- Safety instrument system for ESD
- CCTV
- HVAC System

operators to learn about the operating status of the whole plant. The CCR and ECR will be equipped with the centralized air conditioning system.

New 220kV substation will be monitored in the new network control building.

### **2.3.1.11 Hydrogen generation System**

There are two (02) hydrogen generation plants in the existing power station. The design capacity of each plant is 6 Nm<sup>3</sup>/h and these old inefficient plants are working on 50% capacity therefore to increase the capacity a new hydrogen generation system will be installed. Hydrogen supply required by the hydrogen cooling system of the generator will be sourced from the new-built hydrogen generation system. The devices that regulate the hydrogen will be sent to main building by two (02) stainless steel pipes. The design capacity of the plant will be 2×5 Nm<sup>3</sup>/h.

The quality of product hydrogen is as follow:

Purity : ≥99.8 %

Temperature : ≤40°C

Humidity atmospheric pressure dew point ≤-50°C

### **2.3.1.12 Firefighting System**

A dedicated new fire-fighting system will be built for the proposed power plant. Design of the firefighting system is based on NFPA codes.

Independent water supply system for firefighting will be adopted. Two 800 m<sup>3</sup> combined service water and fire-fighting basins are considered to be designed to meet the firefighting water consumption. According to NFPA, capacity of the water tank is based on running pumps at rated capacity with all fire reels / hoses in service and deluge system for continuous 2 hours at the required operating pressure. High pressure regulation system will also be equipped.

An electric fire pump (Q=565m<sup>3</sup>/h, H=105m), a diesel standby fire pump (Q=565m<sup>3</sup>/h, H=105m) and a set of fire protection equipment will be built in the firefighting pump house. According to related specifications, diesel driven fire pump and electric fire pump will be set separately by the firewall.

Fire pipes will be arranged annularly in the plant, and indoor hydrants will be equipped in the buildings. Automatic sprinkler system, water spray system and gaseous extinguishing system will be adopted for the important equipment in turbine house and so on. Gaseous extinguishing system, water spray system or Nitrogen Suppression System will be adopted in central control building. Water spray system will be adopted in transformers. Potable extinguishers or indoor hydrants will be set in the GIS buildings.

According to related code, automatic fire alarm system will be set in steam turbine house, gas turbine house, central control building, transformer, oil tank and auxiliary buildings which have a fire risk. Automatic fire alarm system is composed of main monitoring panel, regional monitoring panel, local monitoring panel and remote diplopia panel, various detectors, manual alarm, alarm, cable and other

equipment. When a fire occurs, fire signal is sent to the local monitoring panel, regional monitoring panel and the main monitoring panel by the detector, fire occurrence time and place can be displayed at all of the control panels, sound and light alarm signals are sent out and operation command is sent to the firefighting systems.

Fire protection system which is designed on NFPA codes will send out alarm signal in the early stage and can realize the concentrated, regional and local monitoring of the fire and also the remote and local control of the firefighting device, what's more, enough equipment capacity to put out the fire once a fire occurs is also equipped.

### 2.3.1.13 Workshop & Laboratories

New warehouse and workshop for the project in question will also built to full fill the operational need of the new power plant

### 2.3.1.14 Water Treatment Plant

In the proposed project, the 2×450MW gas-steam turbine combined cycle straight condensing units will be constructed. Existing water treatment plants cannot meet the demands of demineralized water required for the proposed project. Therefore, a new demineralized water treatment plant will be installed to meet the requirement. The water source for demineralized water treatment system will be city tap water.

Demineralized water produced from the new plant is expected to be qualified in accordance with the following standard:

SiO<sub>2</sub>: ≤10μg/L

Conductivity (25°C): ≤0.10 μs/cm

For the proposed project, the quantity of makeup water for the generating units will be calculated as per the GB 50660-2011 Code for design of fossil fired power plant. Details of the loss of water-steam over the power plant are shown in **Exhibit 2.8**.

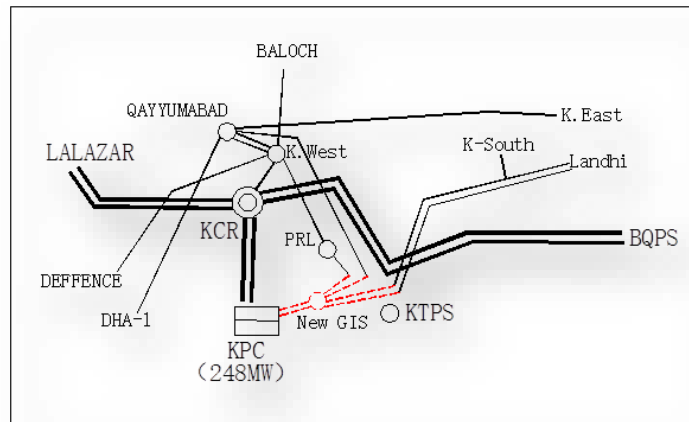
#### Exhibit 2.8: Loss of Water-Steam over Power Plant

Sr. No.	Item	2×450MW
1	Loss from normal water-steam circulation (t/h) (at a rate of about 2%)	16.2
2	Loss from blowdowns (t/h) (at a rate of about 1%)	8.1
3	Normal makeup water quantity (t/h)	24.3
Note: the total amount of evaporation of the triple pressure boiler is 405 t/h.		

Taking into consideration the water demand revealed from the above table as well as such factors as maintenance and repair of the related equipment, the power output of the demineralization unit for the project in question is designed as 25 m<sup>3</sup>/h.

### 2.3.2 Modifications within the Existing Premises of KPC for Proposed BQPS-III Power Project:

As presented in **Exhibit 2.4** location map of KPC a new Grid will be installed right next to entrance gate of KPC cable conduit of 220 kV TR-XLPE to connect 220 kV GIS and auto transformer will be laid along the road within the existing premises of KPC. The existing evacuation system of KPC is shown as **Figure 9**.



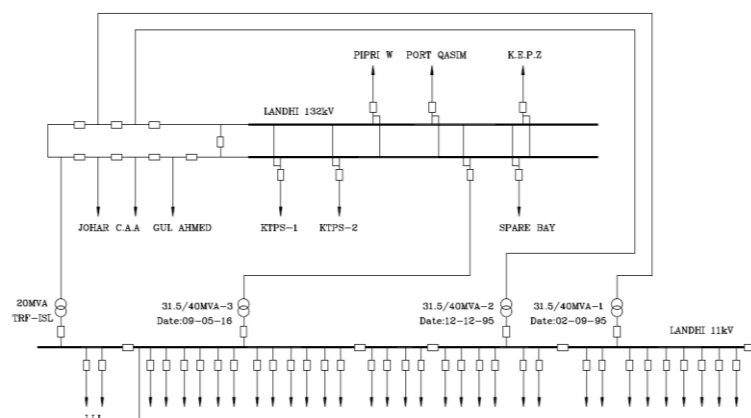
**Figure 9:** The Existing Evacuation System of KPC

Moreover it is important to note that for the proposed BQPS-III Power Project, following installations within KPC will take place:

- Installation of two sets of 250MVA (220kV/132kV) auto transformers to connect 220kV system with 132kV system.
- Extension of 220kV GIS bus with two transformer bays for which, switchgear room will be extended up to 6m with protection and control equipment.
- Construction of a new 132kV GIS building to accommodate the GIS and related protection and control equipment.
- Modification of 132kV outgoing transmission lines from 132kV GIS to first tower near site fence
- 220kV TR-XLPE to connect 220kV GIS and auto transformer.

### 2.3.3 Modifications within the Existing Premises of Landhi Grid Station for Proposed BQPS-III Power Project:

As presented in **Exhibit 2.5** location map of proposed 132 kV GIS Grid Station at Existing Landhi Grid station for BQPS-III power project the exhibit title itself suggests that a new 132 kV GIS Grid Station will be installed within the existing boundaries of the grid station (Refer **Figure 8** for Landhi evacuation system)



**Figure 10:** Landhi evacuation system

### 2.3.4 Modifications within the Existing Premises of Qayyumabad Grid Station for Proposed BQPS-III Power Project:

As presented in **Exhibit 2.6** location map of proposed 132 kV GIS will be installed within the existing facility. The existing 132 kV power distribution unit at Qayyumabad is indoor AIS equipment and main electrical connection uses double-bus wiring. The 132 kV power distribution unit at Korangi West station is indoor AIS equipment and main electrical connection uses open-ended ring like wiring. At present, 132 kV buses of both stations are connected via tubular copper busbar.

In this proposed project, following modifications will take place:

- Two dis-connectors will be added to the 132 kV bus that will connect Qayyumabad to Korangi West. Two disconnector terminal boxes in place and one Bus Bar Protection Relay Panel in relay room will be added. A monitoring and control device will be added in this project which is used to provide control and interlock signal of disconnector and collect the location of the disconnector.
- Replacements of four sets of 31.5 kA equipment at 132 kV Korangi West station with 40 kA equipment and the length of the cable will be about 8km. (Refer figure 9 for Main Electric Wiring of 132kV Qayyumabad and Korangi West Grid Station)

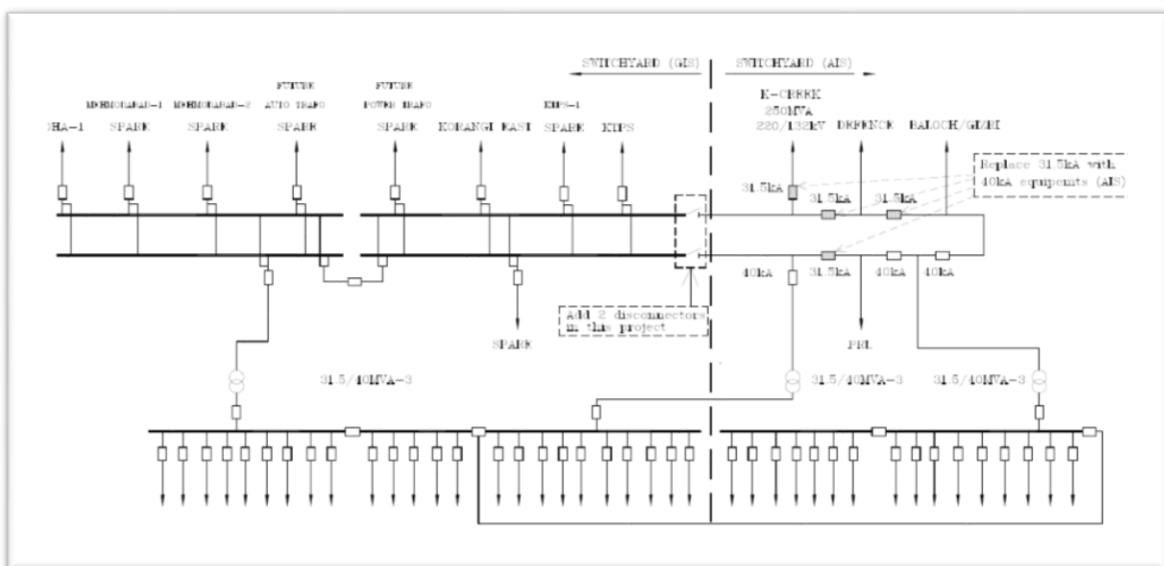
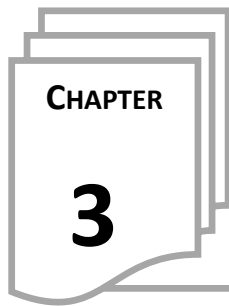


Figure 11 Main Electrical Wiring



# INSTITUTIONAL, LEGISLATION AND POLICY FRAMEWORK

## 3.1 GENERAL OUTLINE AND SCOPE

This section of the EIA document gives an overview of the policy framework and national legislation that applies to the proposed Project. The proposed project is expected to comply with all the applicable Provincial and National legislation guidelines relating to environmental and social aspects, and all the required regulatory clearances will be obtained.

The environmental study primarily includes review of EIA/IEE regulations 2014 of Sindh Environmental Protection Act. Other laws and guidelines relevant to the project as given in **Exhibit 3.1** have also been reviewed.

**Exhibit 3.1:** Policies, Legislation and Guidelines

Provincial and National Environmental Policy, Legislation and Guidelines
National Conservation Strategy (NCS)
National Environmental Policy 2005
National Climate Change Policy, 2011
National Power Policy, 2013
National Environmental Action Plan-Support program (NEAP-SP)
Sindh Environmental Protection Act 2014
Land Acquisition Act, 1894
Pakistan Penal Code (1860)
Port Qasim Authority Act, 1973 (Modified in 2002)
The Antiquities Act
The Factories Act, 1934
Electricity Act, 1910

Sindh Wildlife Protection (Amendment) Act 2008
Sindh Forest Act (2012)
The Sindh Fisheries Ordinance, 1980
Sectoral Guidelines for Thermal Power Stations, 1997
<b>National and International Guidelines or Standards</b>
The Pakistan Environmental Assessment Procedures, 1997
OSHA Standards Health Safety
World Bank Guidelines on Environment
World Bank EHS General Guidelines, 2007

## 3.2 PROVINCIAL AND NATIONAL ENVIRONMENTAL POLICY, LEGISLATION AND GUIDELINES

The enactment of comprehensive legislation on the environment, covering multiple areas of concern, is a relatively new and ongoing phenomenon in Pakistan. Whereas, a basic policy and legislative framework for the protection of the environment and overall biodiversity in the country is now in place, detailed rules, regulations and guidelines required for the implementation of the policies and enforcement of legislation are still in various stages of formulation and discussion. A brief overview of the existing national policies, legislation and guidelines is presented below.

### 3.2.1 National Conservation Strategy (NCS)

The National Conservation Strategy (NCS) is the primary Policy document of the Government of Pakistan on national environmental issues. The Policy was approved by the Federal Cabinet in March 1992. The Strategy also attained recognition by international donor agencies, principally the World Bank. The NCS identifies 14 core areas including conservation of biodiversity, pollution prevention and abatement, soil and water conservation and preservation of cultural heritage and recommends immediate attention to these core areas in order to preserve the country's environment.

A midterm review of the achievements of the NCS in 2000 concluded that achievements under the NCS have been primarily awareness raising and institutional building rather than actual improvement to environment and natural resources and that the NCS was not designed and is not adequately focused as a national sustainable development strategy<sup>1</sup>. The need therefore arose for a more focused National Environmental Action Plan (NEAP) required to bring about actual improvements in the state

<sup>1</sup>Arthur J. Hanson et al, Pakistan's National Conservation Strategy Renewing Commitment to Action, Report of the Mid-Term Review, 2000

of the national environment with greater emphasis on poverty reduction and economic development in addition to environmental sustainability.

The NEAP was approved by the Pakistan Environmental Protection Council under the chairmanship of the President/Chief Executive of Pakistan in February 2001. NEAP now constitutes the national environmental agenda and its core objective is to initiate actions that safeguard public health, promote sustainable livelihoods, and enhance the quality of life of the people of Pakistan.

A National Environmental Policy has been approved by the Federal Cabinet in its meeting held during June 2005<sup>2</sup>. This policy has already been endorsed by the Pakistan Environmental Protection Council during 2004. The new policy has total 171 guidelines on sectoral and cross-sectoral issues. The objectives of new policy include assurance of sustainable development and safeguard of the natural wealth of country. The following are the approved Sectoral Guidelines;

- Water Supply and Management;
- Air Quality and Noise;
- Waste Management;
- Forestry;
- Biodiversity and Protected Areas;
- Climate Change and Ozone Depletion;
- Energy Efficiency and Renewable;
- Agriculture and Livestock;
- Multilateral Environmental Agreements.

### **3.2.2 National Environmental Policy 2005**

The national environmental policy aims to protect, conserve and restore Pakistan's environment in order to improve the quality of life of the citizens through sustainable development. The objectives of the policy are:

- Conservation, restoration and efficient management of environmental resources.
- Integration of environmental considerations in policy making and planning process.
- Capacity building of government agencies and other stockholders at all level for better environmental management.
- Meeting international obligations effectively in line with the national aspirations.
- Creation of a demand for environment through mass awareness and community mobilization<sup>3</sup>.

---

<sup>2</sup>National Environmental Policy, GoP, 2005

<sup>3</sup>National Environmental Policy, 2005.



### **3.2.3 National Climate Change Policy, 2011**

To ensure that climate change is mainstreamed in the economically and socially vulnerable sectors of the economy and to steer Pakistan towards climate resilient development. The main objectives of Pakistan's Climate Change Policy include:

- To pursue sustained economic growth by appropriately addressing the challenges of climate change.
- To integrate climate change policy with other inter-related national policies.
- To focus on pro-poor gender sensitive adaptation while also promoting mitigation to the extent possible in a cost-effective manner.
- To ensure water security, food security and energy security of the country in the face of the challenges posed by climate change.
- To minimize the risks arising from the expected increase in frequency and intensity of extreme weather events such as floods, droughts and tropical storms.
- To strengthen inter-ministerial decision making and coordination mechanisms on climate change.
- To facilitate effective use of the opportunities, particularly financial, available both nationally and internationally.
- To foster the development of appropriate economic incentives to encourage public and private sector investment in adaptation measures.
- To enhance the awareness, skill and institutional capacity of relevant stakeholders.
- To promote conservation of natural resources and long term sustainability<sup>4</sup>.

### **3.2.4 National Power Policy, 2013**

The Ministry of Water and Power of the Government of Pakistan has developed an ambitious power policy to support the current and future energy needs of the country. This bold strategy will set Pakistan on a trajectory of rapid economic growth and social development. Simultaneously, it will address the key challenges of the power sector in order to provide much needed relief to the citizens of Pakistan.

- Build a power generation capacity that can meet Pakistan's energy needs in a sustainable manner.
- Create a culture of energy conservation and responsibility.
- Ensure the generation of inexpensive and affordable electricity for domestic, commercial, and industrial use by using indigenous resources such as coal (Thar coal) and hydel.
- Minimize pilferage and adulteration in fuel supply

---

<sup>4</sup> National Climate Change Policy, 2011.

- Promote world class efficiency in power generation
- Create a cutting edge transmission network
- Minimize inefficiencies in the distribution system
- Minimize financial losses across the system
- Align the ministries involved in the energy sector and improve the governance of all related federal and provincial departments as well as regulators<sup>5</sup>.

### **3.2.5 National Environmental Action Plan-Support program (NEAP-SP)**

The government of Pakistan and United Nations Development Program (UNDP) have jointly initiated an umbrella support program called the National Environmental Action Plan-Support program (NEAP-SP) signed in October 2001 and implemented in 2002. The development objective supported by NEAP-SP is environmental sustainability and poverty reduction in the context of economic growth.

### **3.2.6 Sindh Environmental Protection Act 2014**

The Sindh Environmental Protection Act, 2014 (SEPA 2014) is the basic legislative tool empowering the government to frame regulations for the protection of the environment. The SEPA 2014 is broadly applicable to air, water, soil, marine and noise pollution. Penalties have been prescribed for those contravening the provisions of the Act.

The two primary deliberations of the Act are the conduct of projects only after approval of environmental assessments from the SEPA and adherence with Sindh Environmental Quality Standards (SEQS).

#### **3.2.6.1 EIA Approval Mechanism from Sindh Environment Protection Agency (SEPA)**

As per the 2014 Regulations, Proponent will submit an EIA report for their project activities to SEPA and seek approval on the same from the agency. Ten hard copies and 2 soft copies of the EIA report will be submitted to SEPA. It will then grant its decision on the EIA as per the rules and procedures set out in the 2014 Regulations. The following rules will apply:

- A fee is payable to SEPA for review of the EIA;
- The EIA submission is to be accompanied by an application in the format prescribed in Schedule V of the 2014 Regulations;
- SEPA is bound to conduct a preliminary scrutiny and reply within four weeks of the submission of the report a) confirming completeness, or b) asking for additional information, if needed;

---

<sup>5</sup> National Power Policy, 2013

- The proponent will publish a public notice in any English or Urdu national newspaper and in a local newspaper of general circulation in the area affected by the project. The public notice will mention the following:
  - o The type of project;
  - o The location of the project;
  - o The name and address of the proponent;
  - o The places at which the EIA can be accessed;
  - o The date, time and place for public hearing of any comments on the project or its EIA;
- The date set for public hearing will not be earlier than fifteen (15) days from the date of publication of the public notice
- In the review process SEPA may consult a Committee of Experts, which maybe constituted on the request of the DG SEPA;
- On completion of the review process, the decision of SEPA will be communicated to the proponent in the form prescribed in Schedule V;
- Where an EIA is approved, SEPA can impose additional controls as part of the conditions of approval;
- SEPA is required to make every effort to complete the EIA review process within four months;
- The approval will remain valid for the project duration mentioned in the EIA but on the condition that the project commences within a period of three years from the date of approval. If the project is initiated after three years from approval date, the proponent will have to apply for an extension in the validity period. The SEPA on receiving such request grant extension (not exceeding 3 years at a time) or require the proponent to submit a fresh EIA if in the opinion of SEPA changes in baseline conditions or the project so warrant;
- After receiving approval from SEPA the proponent will acknowledge acceptance of the conditions of approval by executing an undertaking in the form prescribed in Schedule VI of the 2014 Regulations;
- The 2014 Regulations also require proponents to obtain from SEPA, after completion of the project, a confirmation that the requirements of the EIA and the conditions of approval have been duly complied with;
- The SEPA in granting the confirmation of compliance may impose any additional control regarding the environmental management of the project or the operation, as it deems necessary.

### 3.2.6.2 Sindh Environmental Protection Agency Review of IEE and EIA Regulations, 2014

The SEPA Review of IEE and EIA Regulations, 2014 (The 2014 Regulations) promulgated under SEPA 2014 were enforced on December, 2014. The 2014 Regulations define the applicability and procedures for preparation, submission and review of IEEs and EIAs. These Regulations also give legal status to the Pakistan Environmental Assessment Procedures prepared by SEPA in 2014.

The Regulation classifies projects on the basis of expected degree of adverse environmental impacts and lists them in two separate schedules. Schedule I lists projects that may not have significant environmental impacts and therefore require an IEE. Schedule II lists projects of potentially significant environmental impacts requiring preparation of an EIA. The Regulations also require that all projects located in environmentally sensitive areas require preparation of an EIA.

The following project falls under the following category:

#### **Schedule II (EIA):**

Category A Energy

“Thermal power generation over 100MW”

### 3.2.6.3 The Sindh Environmental Quality Standards

During the construction and post development phase of the project SEQs will apply to any effluents during operation and emissions. The complete SEQs 2015 is attached as **Annexure-II**. SEQs Standards for disposal of solid waste have as yet not been promulgated<sup>6</sup>.

### 3.2.6.4 Hazardous Substance Rules, 2014

The Sindh Hazardous Substances Rules, 2014 are a set of rules derived from the Sindh Environmental Act, 2014 and are first of the very specific hazardous substances regulations brought into force in 2014 after the initial draft set of rules devised in 2003. They represent specific regulations with aspect of handling, storage and disposal of hazardous substances and issuing an approving license to the user or facility. The Schedule-I of the Rules enlists the hazardous substances that are under the scrutiny of the Sindh-EPA<sup>7</sup>.

Under its licensing terms, the Rules highlight particular components as follows:

- Employment of Qualified technical personnel
- Packing and labelling
- Conditions of Premises
- Safety precautions
- Trainings

<sup>6</sup> Library, Sindh Environmental Protection Agency, 2016

<sup>7</sup> Hazardous Substances Rules, 2014; Attached as **Annexure-III**

- A comprehensive safety plan
- Waste management Plan and
- Transporting of hazardous substances.

### **3.2.6.5 The Sindh Environmental Quality Standards (Self-Monitoring and Reporting by Industry) Rules, 2014**

These rules are called the Sindh Environmental Quality Standards (Self-Monitoring and Reporting by Industry) Rules, 2014, which is entirely based on the honor system, emerged from a dialogue between the government and industrial representatives. These reports are submitted by an industrial unit to agency in respect of priority parameters. Priority parameters are parameters of Sindh environmental quality standards which selected for the purpose of submission of Environmental Monitoring Reports to the Agency by an industrial unit. Industrial unit responsible for the correct and timely submission report to the agency. On the basis of the pollution level of an industrial unit, the Director General shall classify the unit into category "A", "B" or "C" for liquid effluents, and category "A" or "B" for gaseous emissions.

#### **Category "A" Industrial unit**

An industrial unit in category "A" shall submit environmental monitoring reports on monthly basis. An industrial unit in category "A" shall maintain a record of the times during which start-up and upset conditions occur, and shall mention the total time elapsed in such conditions in its monthly environmental monitoring report.

#### **Category "B" Industrial unit**

An industrial unit in category "B" shall submit environmental monitoring reports on quarterly basis.

#### **Category "C" Industrial unit**

An industrial unit in category "C" shall submit environmental monitoring reports on biannual basis for priority parameters in respect of liquid effluents.

All measurements of priority parameters contained in the environmental monitoring report submitted by an industrial unit shall be based on test reports of a certified environmental laboratory, and attested copies of such results shall be attached with the environmental monitoring report. The gaseous emissions report shall cover the priority parameters listed in Schedule-VII, and shall include, every two years, metal analysis of all gaseous emissions from the industrial unit<sup>8</sup>.

### **3.2.6.6 Tribunal Rules for Non-Compliance**

A failure to comply with any provision of these Rules (except rule 8(1), 16(1), 23 or 25) or any order of the Tribunal (except for an order under rules 38 or 39) does not of itself render void the proceedings

---

<sup>8</sup> The Sindh Environmental Quality Standards (Self-Monitoring and Reporting by Industry) Rules, 2014

or any step taken in the proceedings. In the case of such non-compliance, the Tribunal may take such action as it considers just, which may include:

- Waiving or varying the requirement.
- Striking out the claim or the response, in whole or in part, in accordance with rule 34.
- Barring or restricting a party's participation in the proceedings.
- Awarding costs in accordance with rules 69 - 75<sup>9</sup>.

### **3.2.7 Land Acquisition Act, 1894**

The Land Acquisition Act (LAA) of 1894 amended from time to time has been the defacto policy governing land acquisition, resettlement and compensation in the country. The LAA is the most commonly used law for acquisition of land and other properties for development projects. It comprises of 55 sections pertaining to area notifications and surveys, acquisition, compensation and apportionment awards and disputes resolution, penalties and exemptions.

### **3.2.8 Pakistan Penal Code (1860)**

The Pakistan Penal Code (1860) authorizes fines, imprisonment or both for voluntary corruption or fouling of public springs or reservoirs so as to make them less fit for ordinary use<sup>10</sup>.

### **3.2.9 Port Qasim Authority Act, 1973 (Modified in 2002)**

This Act provides for the establishment of the Port Qasim Authority, defines its functions, powers and internal organization and lays down rules relative to management of and navigation in marine ports and inland waterways ports. The particular sections applicable to the Project are:

- Section 71(B) (2) No Owner, Agent or Master of a vessel, or any industry, manufacturing establishment, mill, factory or any kind, cargo handling company, terminal operator, etc., shall discharge any solid or liquid, waste, oily, noxious radioactive and hazardous substances, bilge discharges, residues and mixtures containing noxious solid and liquid wastes, de-blasting of un-washed cargo tanks and line washing, garbage, emission of any effluent or waste or air pollution or noise in any amount concentration or level in excess of the National Environmental Quality Standards, or standards, which may be specified, from time to time, by the Authority for Port limits.
- Section 71(B) (3) Any person contravening the provisions of sub-section (2) shall be liable to penalty as determined and notified by the authority from time to time for each contravention in addition to the charges for cleaning of the Port and removal of pollution therefrom.
- Section 71 (C) (1) No proponent of a project shall commence construction or operation unless he has filed with this Authority as initial environmental examination or, where the project is

---

<sup>9</sup> The Employment Tribunals Rules of Procedure 2013

<sup>10</sup> www.fmu.gov.pk

likely to cause an adverse environmental effect, an environment impact assessment, and has obtained from the authority approval in respect thereof.

- Section 71 (C) (2) The Authority shall: - (a) review the initial environmental examination and accord its approval, or required submission of an Environmental Impact Assessment by the proponent; or (b) review the Environmental Impact Assessment and accord its approval subject to such condition as it may deem fit to impose, or require that the Environment Impact Assessment be re-submitted after such modification as may be stipulated (pqa.gov.pk,2016)<sup>11</sup>

### **3.2.10 The Antiquities Act**

The Antiquities Act of 1975 ensures the protection of cultural resources of Pakistan. The Act is designed to protect 'antiquities' from destruction, theft, negligence, unlawful excavation, trade, and export. Antiquities have been defined in the Act as ancient products of human activity, historical sites, or sites of anthropological or cultural interest, national monuments, etc. The law prohibits new construction in the proximity of a protected antiquity and empowers the Government of Pakistan to prohibit excavation in any area that may contain articles of archaeological significance.

Under the Act, the project proponents are obligated to:

- Ensure that no activity is undertaken in the proximity of a protected antiquity;
- Report to the Department of Archeology, Government of Pakistan, any archeological discovery made during the course of a project<sup>12</sup>.

### **3.2.11 The Factories Act, 1934**

The clauses relevant to the project are those that concern to health, safety and welfare of workers, disposal of solid waste and effluent and damage to private and public property. The Factories Act also provides regulation for handling and disposal of toxic and hazardous materials<sup>13</sup>.

### **3.2.12 Electricity Act, 1910**

The Act provides a legal base for power distribution. A licensee under this Act is enabled to operate supply of electricity. This Act obligate licensee to pay compensation for any damages caused during the constructions and maintenance of any power distribution facilities.

### **3.2.13 Sindh Wildlife Protection (Amendment) Act 2008**

The Sindh Wildlife Ordinance 1972 empowers the government to declare certain areas reserved for the protection of wildlife and to control activities within these areas. It also provides protection to endangered species of wildlife<sup>14</sup>.

---

<sup>11</sup> [http://pqa.gov.pk/pqa\\_act.php](http://pqa.gov.pk/pqa_act.php)

<sup>12</sup> [pakistancode.gov.pk](http://pakistancode.gov.pk), 2005

<sup>13</sup> The Pakistan code (The Factories Act, 1934)

<sup>14</sup> [faolex.fao.org](http://faolex.fao.org), 2009

### **3.2.14 Sindh Forest Act (2012)**

The act empowers the provincial forest departments to declare any forest area as reserved or protected. The Act also empowers the provincial forest departments to prohibit the clearing of forest for cultivation, grazing, hunting, removing forest produce; quarrying and felling, lopping and topping of trees, branches in reserved and protected forests<sup>15</sup>.

### **3.2.15 The Sindh Fisheries Ordinance, 1980**

The Sindh Fisheries Ordinance, 1980 regulates fishing in the public waters, including the coastal areas, of Sindh. It empowers the government of Sindh to issue licenses for fishing in public waters, put restriction on the type of equipment that can be used for fishing, restrict fishing in certain areas or of certain species of fish, regulate the onshore trade of fish catch, and regulate the fish processing industry. Article 8 of the Ordinance prohibits the discharge of wastewater to public waters without the consent of the Director Fisheries.

### **3.2.16 Sectoral Guidelines for Thermal Power Stations, 1997**

The sectoral guidelines deal with major thermal power plants producing electrical energy from fossil fuels (coal, gas, oil). The guideline is prepared to assist project proponents to identify the key environmental parameters those are required to be addressed to develop mitigation measures and alternatives that need to be considered in the EIA.

## **3.3 NATIONAL AND INTERNATIONAL GUIDELINES OR STANDARDS**

### **3.3.1 The Pakistan Environmental Assessment Procedures, 1997**

The Pakistan Environmental Protection Agency prepared the Pakistan Environmental Assessment Procedures in 1997. They are based on much of the existing work done by international donor agencies and Non-Governmental Organizations (NGO's). The package of regulations prepared by PEPA includes:

- Policy and Procedures for Filing, Review and Approval of Environmental Assessments;
- Guidelines for the Preparation and Review of Environmental Reports;
- Guidelines for Public Consultation;
- Guidelines for Sensitive and Critical Areas; and
- Sectoral Guidelines for various types of projects.

---

<sup>15</sup>Sindhforests.gov.pk



### **3.3.2 OSHA Standards Health Safety**

The Occupational Safety and Health Administration (OSHA) are issuing safety and health program management guidelines for use by employers to prevent occupational injuries and illnesses. The Occupational Safety and Health Act of 1970 (OSHA) representatives have noted a strong correlation between the application of sound management practices in the operation of safety and health programs and a low incidence of occupational injuries and illnesses. Where effective safety and health management is practiced, injury and illness rates are significantly less than rates at comparable worksites where safety and health management is weak or non-existent.

OSHA has concluded that effective management of worker safety and health protection is a decisive factor in reducing the extent and the severity of work-related injuries and illnesses. Effective management addresses all work-related hazards, including those potential hazards which could result from a change in worksite conditions or practices. It addresses hazards whether or not they are regulated by government standards.

### **3.3.3 World Bank Guidelines on Environment**

The principal World Bank publications that contain environmental guidelines are listed below.

- Environmental Assessment-Operational Policy 4.01. Washington, DC, USA. World Bank 1999.
- Environmental Assessment Sourcebook, Volume I: Policies, Procedures, and Cross-Sectoral Issues. World Bank Technical Paper Number 139, Environment Department, the World Bank, 1991.

The above two publications provide general guidelines for the conduct of EIA's, and address the EIA practitioners themselves as well as project designers. While the Sourcebook in particular has been designed with Bank projects in mind, and is especially relevant for the impact assessment of large-scale infrastructure projects, it contains a wealth of useful information, for environmentalists and project proponents.

The Sourcebook identifies a number of areas of concern, which should be addressed during impact assessment. It sets out guidelines for the determination of impacts, provides a checklist of tools to identify possible biodiversity issues and suggests possible mitigation measures. Possible development project impacts on wild lands, wetlands, forests etc. are also identified and mitigation measures suggested.

### **3.3.4 World Bank EHS General Guidelines, 2007**

The Environmental, Health, and Safety (EHS) Guidelines are technical reference documents with general and industry-specific examples of Good International Industry Practice (GIIP). When one or more members of the World Bank Group are involved in a project, these EHS Guidelines are applied as required by their respective policies and standards. These General EHS Guidelines are designed to be used together with the relevant Industry Sector EHS Guidelines which provide guidance to users on EHS

issues in specific industry sectors. EHS considerations into corporate and facility-level business processes in an organized, hierarchical approach that includes the following steps:

- Identifying EHS project hazards and associated risks as early as possible in the facility development or project cycle, including the incorporation of EHS considerations into the site selection process, product design process, engineering planning process for capital requests, engineering work orders, facility modification authorizations, or layout and process change plans.
- Involving EHS professionals, who have the experience, competence, and training necessary to assess and manage EHS impacts and risks, and carry out specialized environmental management functions including the preparation of project or activity-specific plans and procedures.
- Understanding the likelihood and magnitude of EHS risks, based on:
  - The nature of the project activities
  - The potential consequences to workers, communities, or the environment
- Favoring strategies that eliminate the cause of the hazard at its source, for example, by selecting less hazardous materials or processes that avoid the need for EHS controls.
- Improving EHS performance through a combination of ongoing monitoring of facility performance and effective accountability<sup>16</sup>.

---

<sup>16</sup>Environmental, Health, and Safety General Guidelines

### 4.1 GENERAL OUTLINE AND SCOPE

This section of the ESIA document presents a detailed description of physical environmental conditions of the study area. The data collection techniques are combination of both primary and secondary means by field verifications, observations, sampling and monitoring which was supplemented by review of published literature and previous ESIA studies conducted in the proposed project surrounding areas. The base line data defines, elaborates and present physical environmental quality within the project surrounding. (Refer **Exhibit 4.1** for pictorial presentation of baseline investigations and observations)

#### **Key Features of Physical Baseline**

- Topography and land use
- Geology
- Climate
- Air Quality
- Water Resources
- Water Quality

**Exhibit 4.1:** Pictorial Presentation of Baseline Investigations and Observations

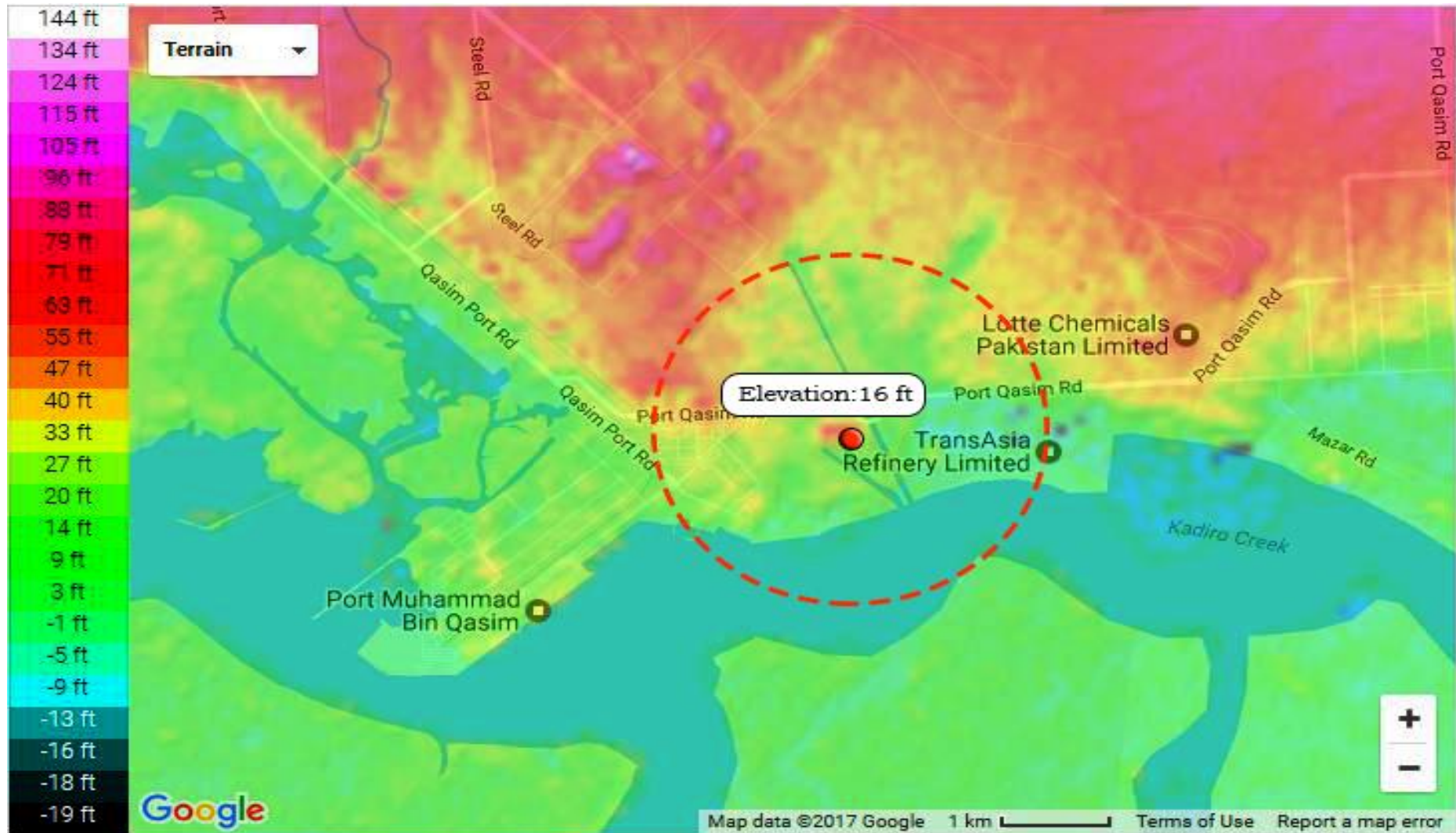


## 4.2 TOPOGRAPHY

The city of Karachi has a land area of 3,640 km<sup>2</sup> and is located on the Arabian Seacoast in the extreme south of Pakistan; the city is located at 24°45" to 25°15" north and 66°37" to 67°37" east. It is bounded by Dadu District in the northeast, Thatta District in the southeast, the Arabian Sea to the south and the Lasbela District of Balochistan Province to the west.

Karachi can be broadly divided into two parts; the hilly areas in the north and west and the coastal area in the southeast. The hilly areas of Karachi are known to be the off-shoots of the Kirthar Range. The highest point of these hills in Karachi is about 528m in the extreme north. These hilly areas are devoid of vegetation and have wide plains, dry river beds and water channels. Karachi has a long coastline in the south. Specifically the topography of the study area is quite gentle and its elevation is increasing as we move towards the north. The land bordering the study area has an elevation less than 20 m above the sea level (amsl) while the land in the northern periphery of the study area lies in-between 10 and 60 m amsl. **Exhibit 4.2** represents the topographic elevation map of the proposed project areas.

**Exhibit 4.2:** Topographic Elevation Map of the Proposed Project Areas



### 4.3 LAND COVER & LAND USE

Land use and Land cover (LULC) composition and its change are the substantial factors having direct influence on urban ecological systems and conditions. The city of Karachi has been through astringent urbanization during last two decades and many studies have been performed for its LULC analysis. According to the Pakistan Economic Survey 2013-2014, Karachi is the largest and the fastest growing urban center of Pakistan offering the most complex set of urban development challenges with a population of about 20 million having annual growth rate of 5%.

The proposed project areas lies in the Malir district of Karachi at Port Qasim to the south where a major portion (65%) of the notified area of Port Qasim comprises of saline channels and creeks of the inactive Indus Delta. The remaining portion is occupied largely by mangroves (22%), mudflats and beaches (9%) and other areas (4%) such as industrial, commercial, residential and agriculture and at other hand landhi and Korangi industrial area mostly occupied with industrial, commercial and residential setup. **Exhibit 4.3** represents the land cover pattern of Karachi, **Exhibit 4.4** represents graphical representation of the land cover pattern of the proposed project area, while Land use pattern in close proximity of the proposed project surrounding at Port Qasim, can be seen as **Exhibit 4.5** respectively.

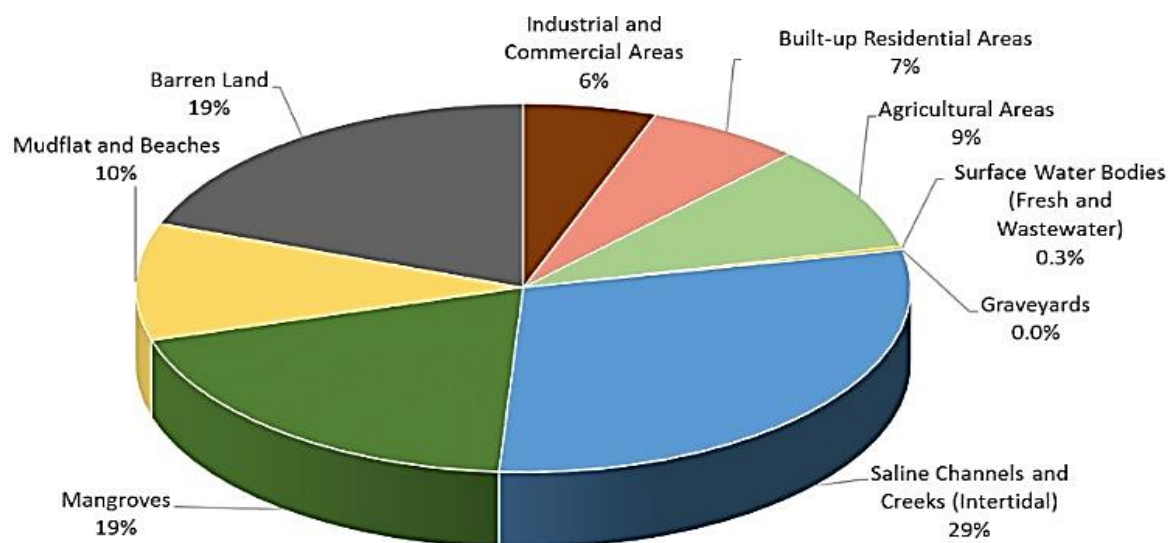
**LAND COVER**

- The physical land type on the surface of the earth.
- Land cover data documents how much of a region is covered by forests, wetlands, impervious surfaces, agriculture, and other land and water types.

**LAND USE**

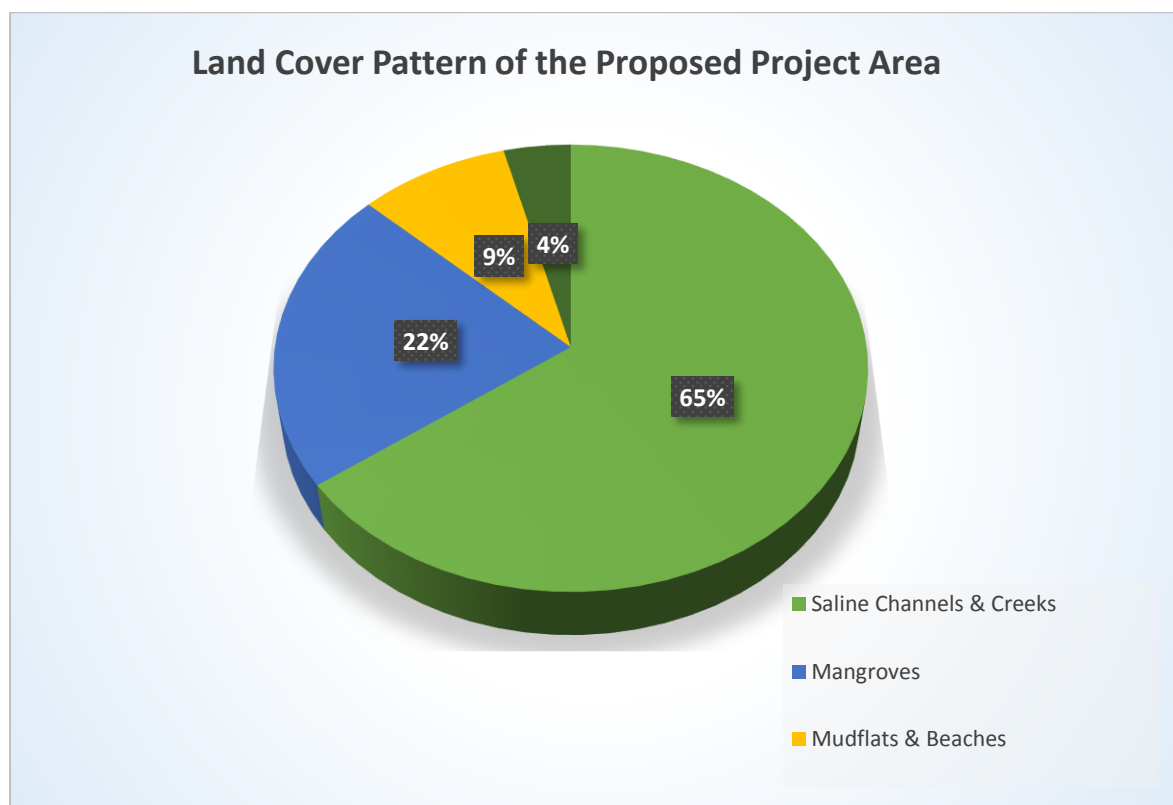
- Land use describes how the land cover is modified.
- There are many types of land use:
  - Recreational -, non-essentials like parks.
  - Transport - roads, railways, and airports.
  - Agricultural - farmland.
  - Residential - housing.
  - Commercial - businesses and factories.

**Exhibit 4.3:** Graphical Representation of Land Cover Pattern of Karachi



**Source:** Cumulative Impact Assessment for Industrial and Port Developments at Port Qasim, Hagler Bailly Pakistan, 2016

**Exhibit 4.4:** Graphical Representation of the Land Cover Pattern of the Proposed Project Area

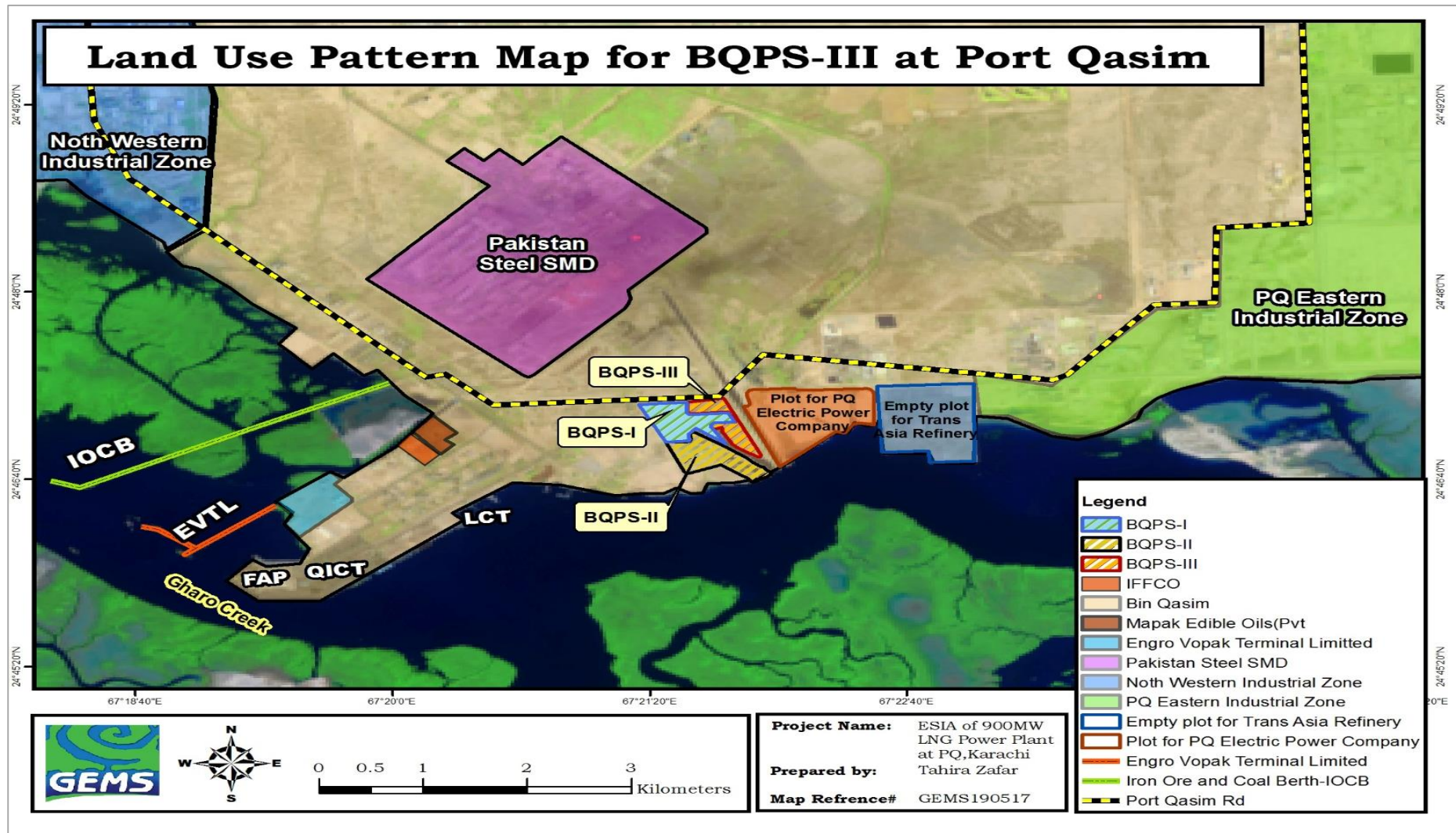


Source: Cumulative Impact Assessment for Industrial and Port Developments at Port Qasim, Hagler Bailly Pakistan, 2016

Land Cover and Use Class	Area (Hectares)
Industrial and Commercial Areas	10,210
Built-up Residential Areas	11,938
Agricultural Areas	17,130
Saline Channels and Creeks (Intertidal)	53,765
Mangroves	35,546
Mudflat and Beaches	18,915
<b>Total Study Area</b>	<b>147,504</b>

Source: Cumulative Impact Assessment for Industrial and Port Developments at Port Qasim, Hagler Bailly Pakistan, 2016

**Exhibit 4.5:** Land use Pattern in Close Proximity of the Proposed Project Area





## 4.4 GEOLOGY

Geology of the area under focus is underlain a lower Indus basin described as Indus river alluvial early Eocene\*. Early deposition of sediments include silt, sand stone, conglomerate, limestone with low compact and cementing materials. Surface features syncline delta and valley region where anticline ridges are exposed. As per stratigraphic description, Gazij and Manchar inclined two formations gently northeast to southeast in offshore. The coastal region is found to be of tertiary and post-tertiary origin. Blatter et al (1929) dates it as recent as Eocene.

The region has been formed by the upheaval of land from the Tethys Sea, which once extended up to the northern border of Pakistan but, gradually withdrew with the rising of the Himalayas. The underlying rocks are mostly of marine origin, highly folded, faulted and fissured everywhere (*Sidra et al, 2010 Situation Analysis of Sindh Coast Issues and Options*).

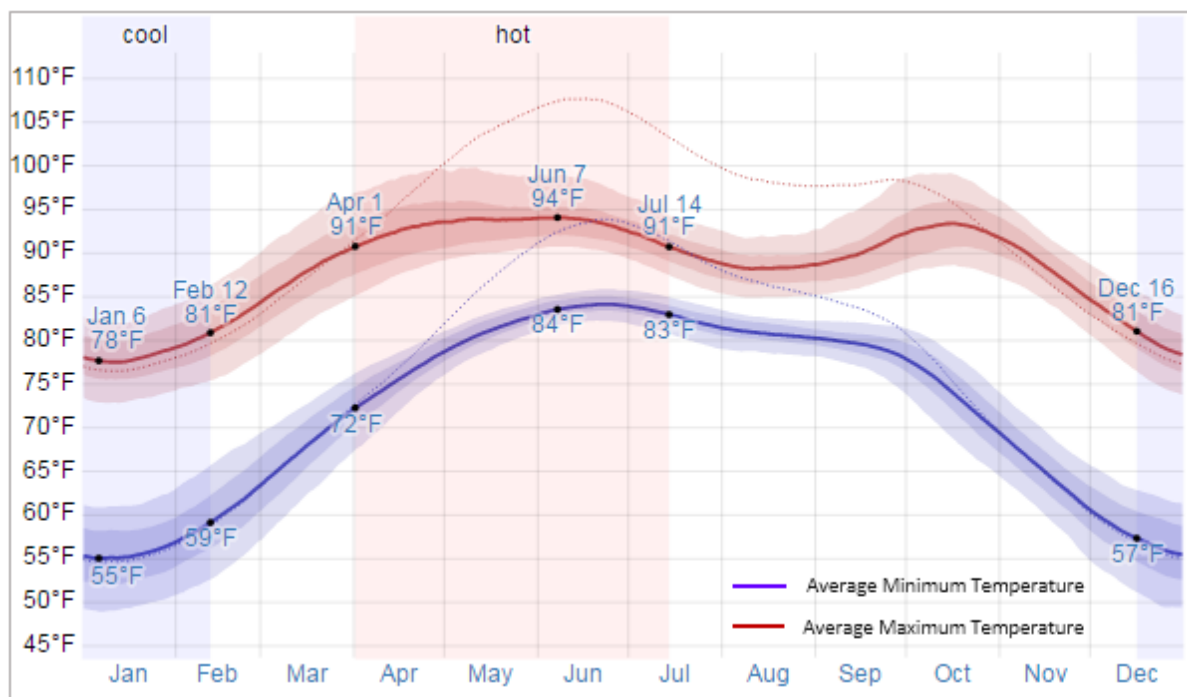
### EOCENE

The Eocene Epoch, lasting from 56 to 33.9 million years ago, is a major division of the geologic timescale and the second epoch of the Paleogene Period in the Cenozoic Era

## 4.5 CLIMATE

The climate of Karachi is characterized as hot and dry during summer, and mild during winter with heavy, sporadic, rainfall during the monsoon. The summer monsoon prevails in the Proposed Project area from Mid-March to Mid-June characterized by very hot temperatures, dry conditions, moderate wind from the southwest and low humidity; high rainfall, high temperatures, high humidity characterize Monsoons from Mid-June to Mid-September, and high winds from the southwest. Although the temperatures are milder compared to summer but high humidity makes the heat oppressive; Post-monsoon summer that is from Mid-September to Mid-November is characterized by cessation of rains and reduction in wind speed. Temperature increases by couple of degrees and humid decreases by about 10%; and winters monsoon from Mid-November to Mid-March is characterized by moderate temperature, dry conditions, low humidity, and low winds from the north and northeast. The monsoon is characterized by a reversal in wind direction during the remaining months and heavy rainfall occurs over most part of the Indian Subcontinent. In Karachi over the course of the year, the temperature typically varies from 55°F to 94°F and is rarely below 49°F or above 100°F. Yearly mean maximum and minimum temperatures from January 1, 1980 to December 31, 2016 are presented below in **Exhibit 4.6**.

**Exhibit 4.6:** Mean Maximum and Minimum Temperature (January 1-1980 to December 31-2016)



Source: Weather Spark.com

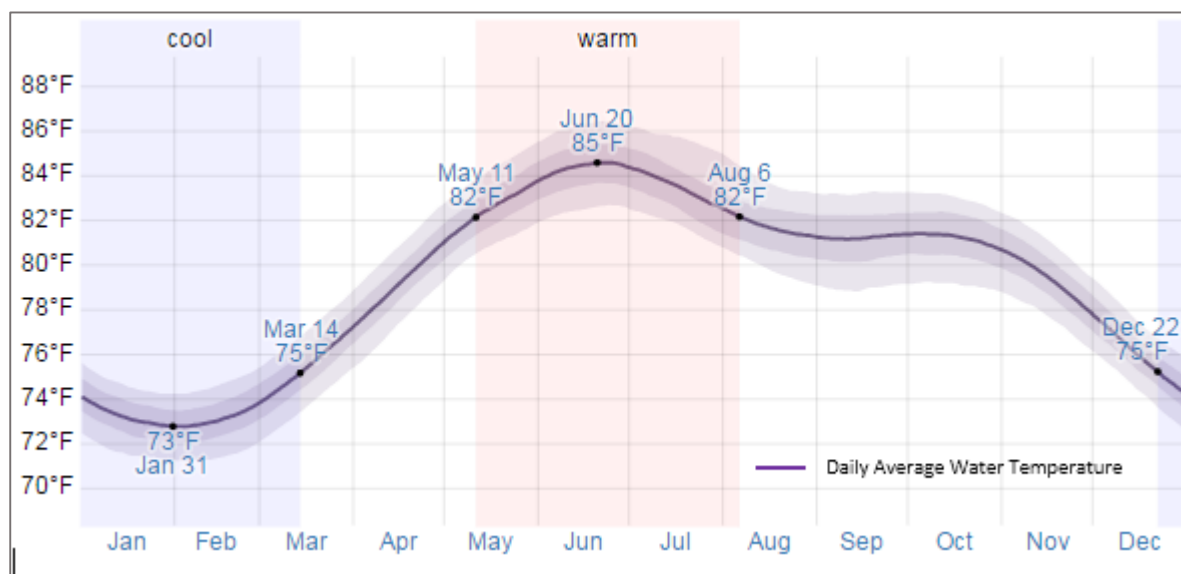
#### 4.5.1 Water Temperature

Karachi is located near a large body of water and over the course of the year the average surface water temperature experiences *some* seasonal variation

The time of year with *warmer water* lasts for *2.8 months*, from *May 11* to *August 6*, with an average temperature above *82°F*. The day of the year with the warmest water is *June 20*, with an average temperature of *85°F*.

The time of year with *cooler water* lasts for *2.7 months*, from *December 22* to *March 14*, with an average temperature below *75°F*. The day of the year with the coolest water is *January 31*, with an average temperature of *73°F*. The mean monthly water temperature from January 1, 1980 to December 31, 2016 are presented below in **Exhibit 4.7**.

**Exhibit 4.7:** Mean Monthly Water Temperature (January 1-1980 to December 31-2016)



#### 4.5.2 Rainfall

According to IPCC report, 2007 decrease in rainfall pattern has been observed along the coastal belt and arid plains of Pakistan, in upcoming years most part of Pakistan will experience dry humid conditions especially Sindh, Balochistan, Punjab and the central parts of Northern Areas will receive less than 250 mm of rainfall in a year (PMD). The yearly average rainfall pattern of Karachi from January 1, 1980 to December 31, 2016 shows some seasonal variation in monthly rainfall.

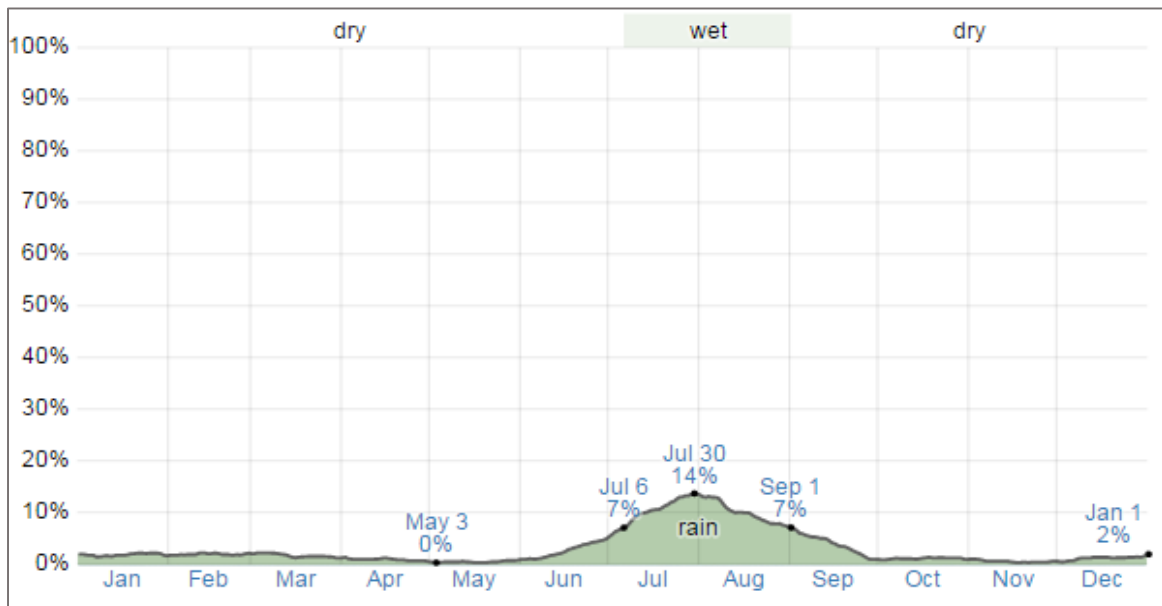
The *rainy period* of the year lasts for *2.7 months*, from June 25 to September 15, with a decrease of at least *0.5 inches* in 31-day rainfall. The most rain falls during the month of July. The *rainless period* of the year lasts for *9.3 months*, from September 15 to June 25. The least rain falls around May.

The probability of precipitation and wet days observed at Port Qasim varies throughout the year. The *wetter season* lasts 1.8 months, from July 6 to September 1, with a greater than 7% chance of a given day being a wet day. The chance of a wet day peaks at 14% on July 30.

The *drier season* lasts 10 months, from September 1 to July 6. The smallest chance of a wet day is 0% on May 3.

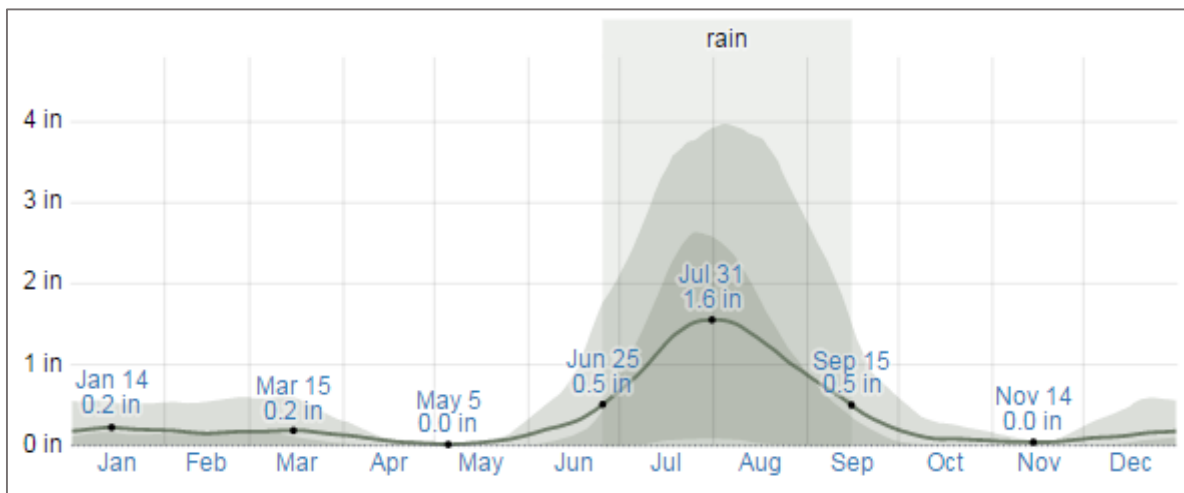
Based on the categorization of *rain alone*, *snow alone*, or a mixture of the two, the most common form of precipitation throughout the year is *rain alone*, with a peak probability of 14% on July 30. The mean monthly precipitation records for Karachi South District can be seen in **Exhibit 4.8**, while **Exhibit 4.9** mean monthly rainfall pattern of Karachi presented below.

**Exhibit 4.8:** Maximum Precipitation (%) (January 1-1980 to December 31-2016)



Source: Weather Spark.com

**Exhibit 4.9:** Average Monthly Rainfall (January 1-1980 to December 31-2016)



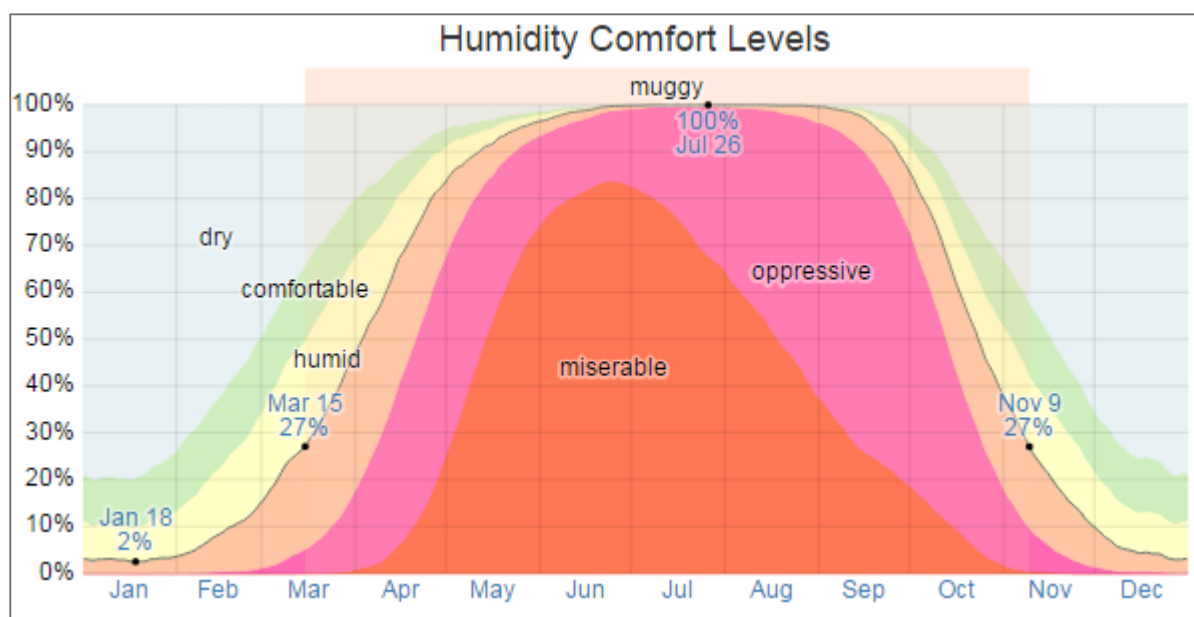
Source: Weather Spark.com

### 4.5.3 Relative Humidity

Karachi experiences *very significant* seasonal variation in the perceived humidity. The humidity comfort level is based on the dew point, as it determines whether perspiration will evaporate from the skin, thereby cooling the body. Lower dew points feel drier and higher dew points feel more humid. Unlike temperature, which typically varies significantly between day and night, dew point tends to change more slowly, so while the temperature may drop at night, a muggy day is typically followed by a muggy night.

The *muggier period* of the year lasts for 7.8 months, from March 15 to November 9, during which time the comfort level is *muggy*, *oppressive*, or *miserable* at least 27% of the time. The *muggiest day* of the year is July 26, with muggy conditions 100% of the time. The *least muggy day* of the year is January 18, with muggy conditions 2% of the time. The mean monthly relative humidity for Karachi South district can be seen in **Exhibit 4.10**.

**Exhibit 4.10:** Relative Humidity



Source: Weather Spark.com

#### 4.5.4 Wind Speed and Direction

The proposed project area lies in a region where wind blows throughout the year with highest velocities. During summer, the direction of the wind is from south-west to west and during winter season the wind blows from north to northeast and it shifts southwest to west in the evening hours. The wind usually carries sand and salt with it resulting in severe corrosion and erosion. The wind direction and speed in between the two monsoon seasons, summer and winter are rather unsettled and large variations have been recorded in terms of speed and direction. The seasonal winds are dry and have a desiccating effect during May & June, in July and August the wind contains moisture.

The average hourly wind speed in Karachi experiences *significant* seasonal variation over the course of the year. The *windier* part of the year lasts for 5.2 months, from April 13 to September 19, with average wind speeds of more than 5.8 miles per hour. The *windiest* day of the year is June 30, with an average hourly wind speed of 8.0 miles per hour.

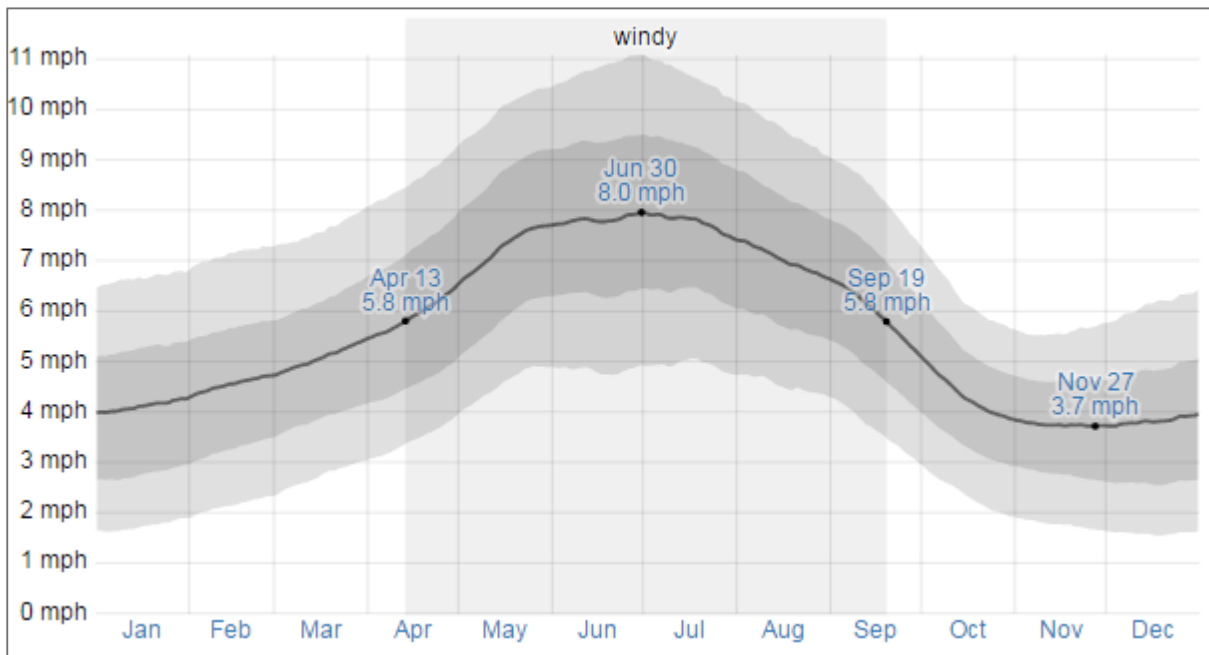
The *calmer* time of year lasts for 6.8 months, from September 19 to April 13. The *calmest* day of the year is November 27, with an average hourly wind speed of 3.7 miles per hour.

The predominant average hourly wind direction in Karachi varies throughout the year. The wind is most often from the west for 11 months, from January 13 to November 30, with a peak percentage

of 92% on May 2. The wind is most often from the north for 1.5 months, from November 30 to January 13, with a peak percentage of 39% on December 8.

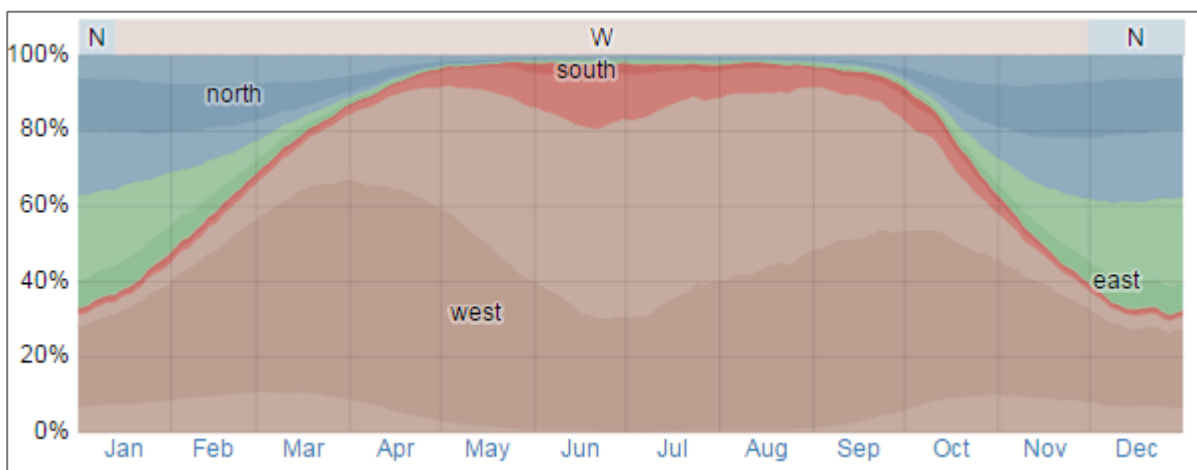
Exhibit 4.11 and 4.12 shows the average wind speed and direction of wind in the proposed project area.

Exhibit 4.11: Average Wind Speed (January 1-1980 to December 31-2016)



Source: Weather Spark.com

Exhibit 4.12: Wind Direction over the Entire Year (January 1-1980 to December 31-2016)



Source: Weather Spark.com

## 4.6 AMBIENT AIR AND NOISE QUALITY

Air pollution has a direct impact on the health of humans and the environment. Different emissions affect air quality. As discussed previously in the chapter-2 project description of this ESIA document, the proposed 2 X 450 MW RLNG CCGU project will include modifications within BQPS-I, KPC, Landhi and Qayyumabad Grid for power evacuation of the proposed project, therefore several existing sources of emissions in Port Qasim, Korangi, Landhi and Qayyumabad were identified and monitored accordingly for baseline air quality establishment. However key focus remained on the main Project site, i.e. BQPS-III, which is located within the vicinity of PQA as the proposed project may contribute to the gaseous emissions and noise generation during constructional and operational phase either positive or negative.

### 4.6.1 Baseline Data

Subsequent to the air quality baseline parameters\* subjected to monitoring, primary baseline data was compiled by mobilizing Global Environmental Laboratory (GEL) team of Environmental Sampling and Monitoring (ESM). The ESM team carried out ambient air monitoring and sampling at sites where small scale modifications and installations are required for the proposed project, the locations included Landhi and Qayyumabad Grid. However it is important to note that ESM team of GEL is already engaged in quarterly environmental monitoring and testing of existing power generation units of KE, therefore data from Quarterly Environmental Monitoring Reports (EMR) of BQPS-I and KPC has also been considered for baseline ambient air quality of the project surrounding. Pictorial profile of ambient air and noise monitoring is presented as **Exhibit 4.13** and the sampling location maps are presented as **Exhibit 4.14** till **Exhibit 4.17**. The monitoring results along with graphical representation is given in **Exhibit 4.18** and **4.19** respectively.

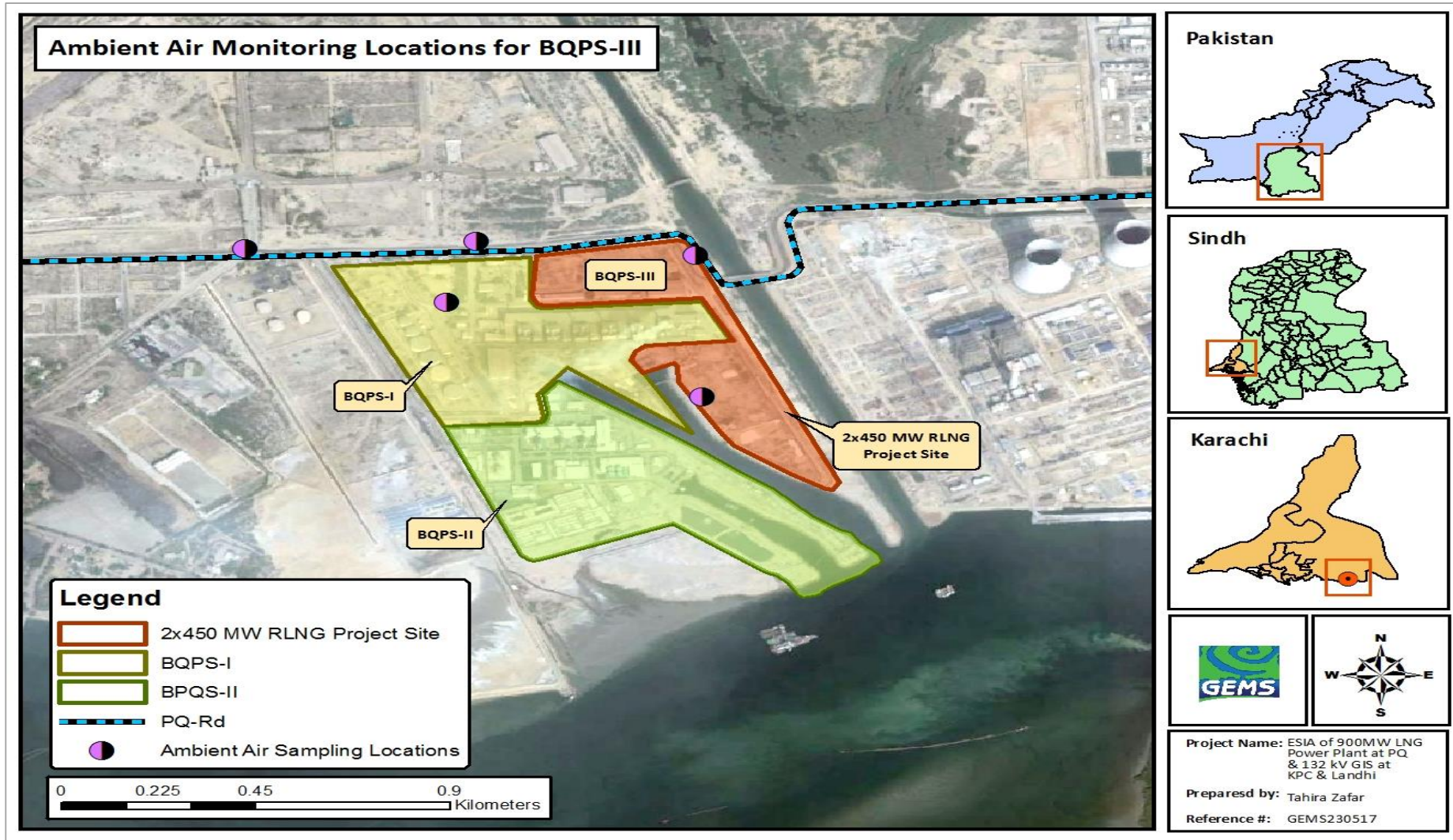
#### Ambient Air Quality Baseline Parameters\*

- PM<sub>10</sub>
- CO<sub>2</sub>
- SO<sub>2</sub>
- NO<sub>x</sub>
- Noise Levels

**Exhibit 4.13:** Pictorial Profile of Ambient Air Quality and Noise level Monitoring

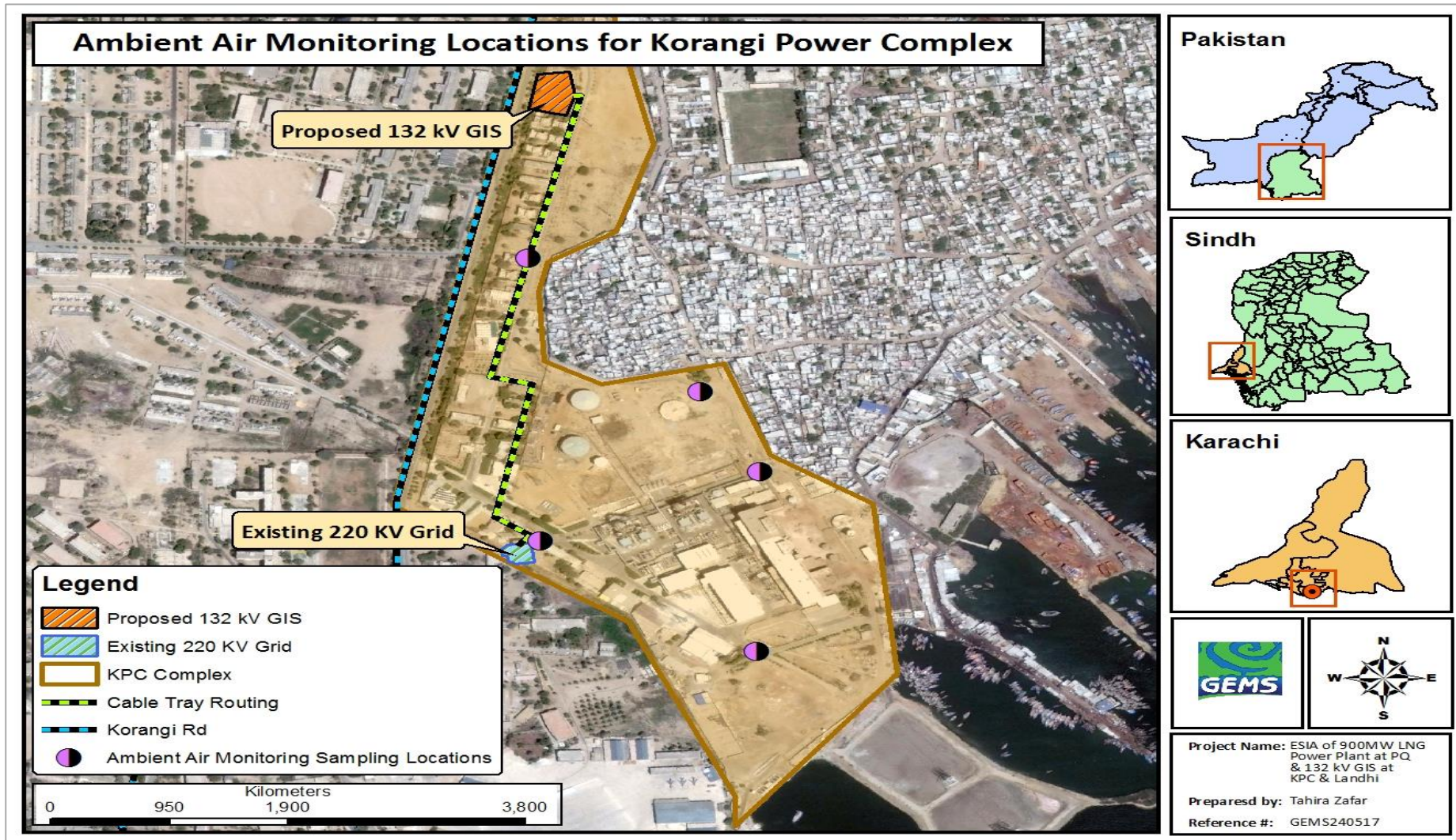


**Exhibit 4.14:** Ambient Air Monitoring Location Map at Port Qasim for BQPS-III Power Project

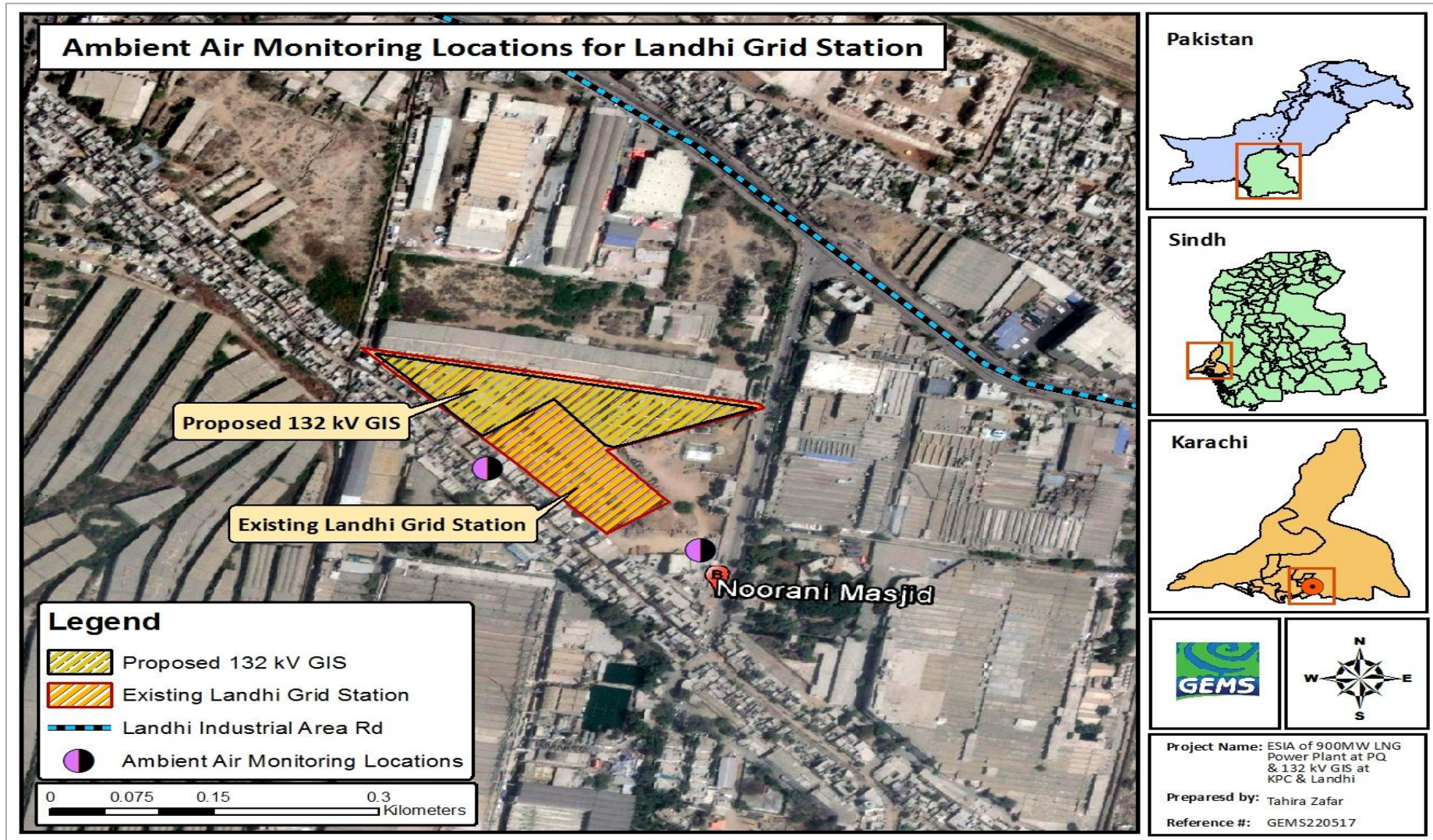




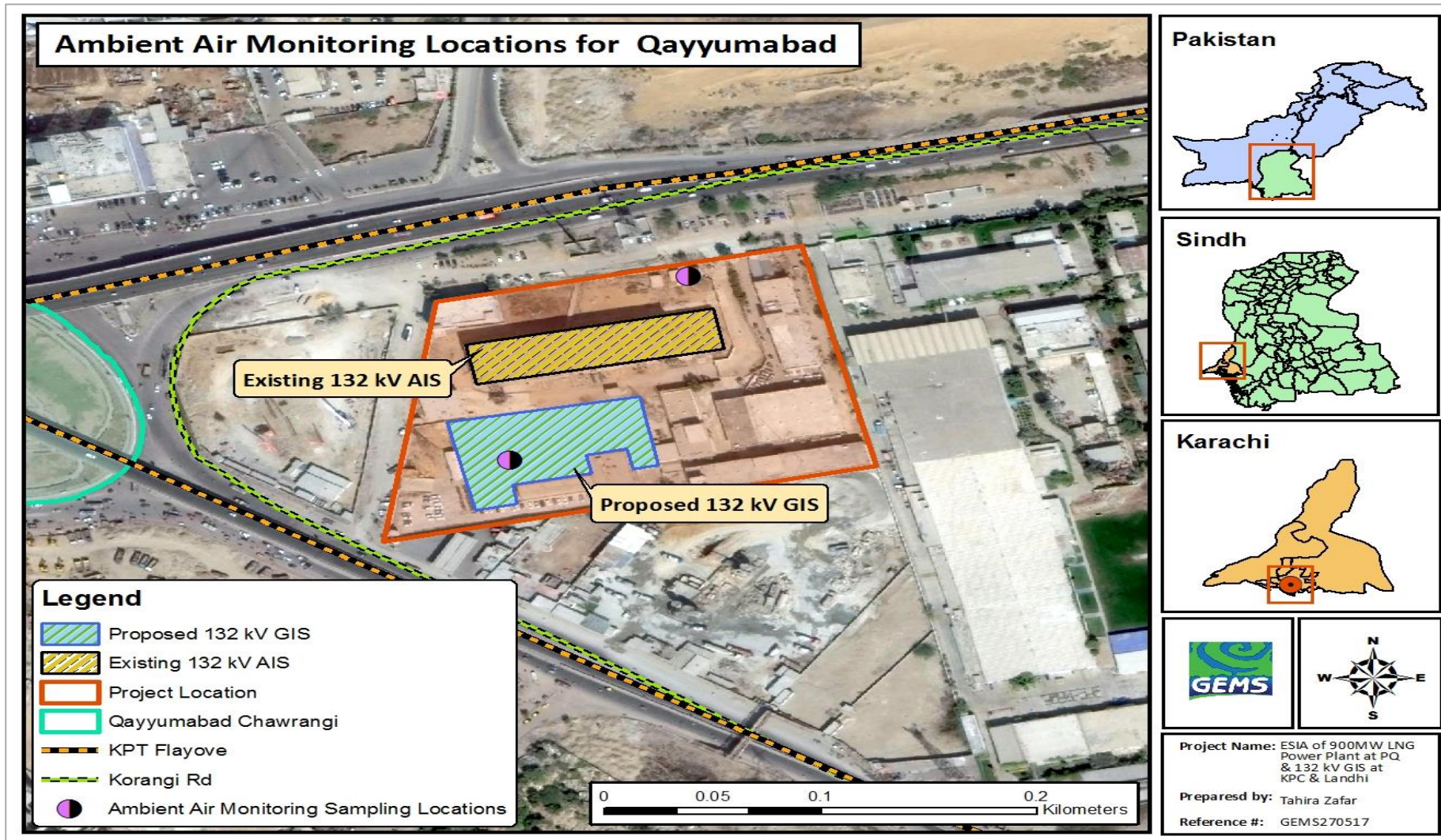
**Exhibit 4.15:** Ambient Air Monitoring Location Map at Korangi-KPC for BQPS-III Power Project



**Exhibit 4.16:** Ambient Air Monitoring Location Map at Landhi for BQPS-III Power Project



**Exhibit 4.17:** Ambient Air Monitoring Location Map at Korangi-Qayyumabad for BQPS-III Power Project



**Exhibit 4.18: Ambient Air Quality and Noise Monitoring Results**

S.no	Parameters	Units	SEQS Limits	Concentration at Port Qasim				
				Near Inside Corner of Eastern Boundary (L-1)	Near Inside Corner of Western Boundary (L-2)	At Front Boundary (L-3)	500m from boundary wall towards East (L-4)	500m from boundary wall towards West (L-1)
1	Carbon Dioxide (CO <sub>2</sub> )	ppm	....	482	463	444	431	437
2	Oxides of Nitrogen (NO <sub>x</sub> )	ug/m <sup>3</sup>	120	<1	<1	<1	<1	<1
3	Sulphur Dioxide (SO <sub>2</sub> )	ug/m <sup>3</sup>	120	<1	<1	<1	<1	<1
4	Particulate Matter PM <sub>10</sub>	ug/m <sup>3</sup>	150	141	147	133	121	113
5	Noise	dB	80	64.5	77	68	64	63.4
S.no	Parameters	Units	SEQS Limits	Concentration at KPC				
				Near Inside Corner of Southern Boundary (L-1)	Near Inside Corner of Northern Boundary (L-2)	At Front Boundary (L-3)	250m from boundary wall towards Northeast (L-4)	500m from boundary wall towards North (L-5)
1	Carbon Dioxide (CO <sub>2</sub> )	ppm	....	484	476	466	471	457
2	Oxides of Nitrogen (NO <sub>x</sub> )	ug/m <sup>3</sup>	120	<1	<1	<1	<1	<1
3	Sulphur Dioxide (SO <sub>2</sub> )	ug/m <sup>3</sup>	120	<1	<1	<1	<1	<1
4	Particulate Matter PM <sub>10</sub>	ug/m <sup>3</sup>	150	87	79	63	76	91
5	Noise	dB	80	63.5	65	61	62.7	62.3

S.no	Parameters	Units	SEQS Limits	Concentration at LGS	
				Near Noorani Masjid	Near Existing LAndhi Grid Station
1	Carbon Dioxide (CO <sub>2</sub> )	ppm	....	452	467
2	Oxides of Nitrogen (NO <sub>x</sub> )	ug/m <sup>3</sup>	120	<1	<1
3	Sulphur Dioxide (SO <sub>2</sub> )	ug/m <sup>3</sup>	120	<1	<1
4	Particulate Matter PM <sub>10</sub>	ug/m <sup>3</sup>	150	96	81
5	Noise	dB	80	64	69
S.no	Parameters	Units	SEQS Limits	Concentration at KGS	
				Proposed site for GIS	At main Gate
1	Carbon Dioxide (CO <sub>2</sub> )	ppm	....	341	394
2	Oxides of Nitrogen (NO <sub>x</sub> )	ug/m <sup>3</sup>	120	<1	<1
3	Sulphur Dioxide (SO <sub>2</sub> )	ug/m <sup>3</sup>	120	<1	<1
4	Particulate Matter PM <sub>10</sub>	ug/m <sup>3</sup>	150	86	71
5	Noise	dB	80	61	72

**Key\***

*SEQS Sindh Environmental Quality Standards*

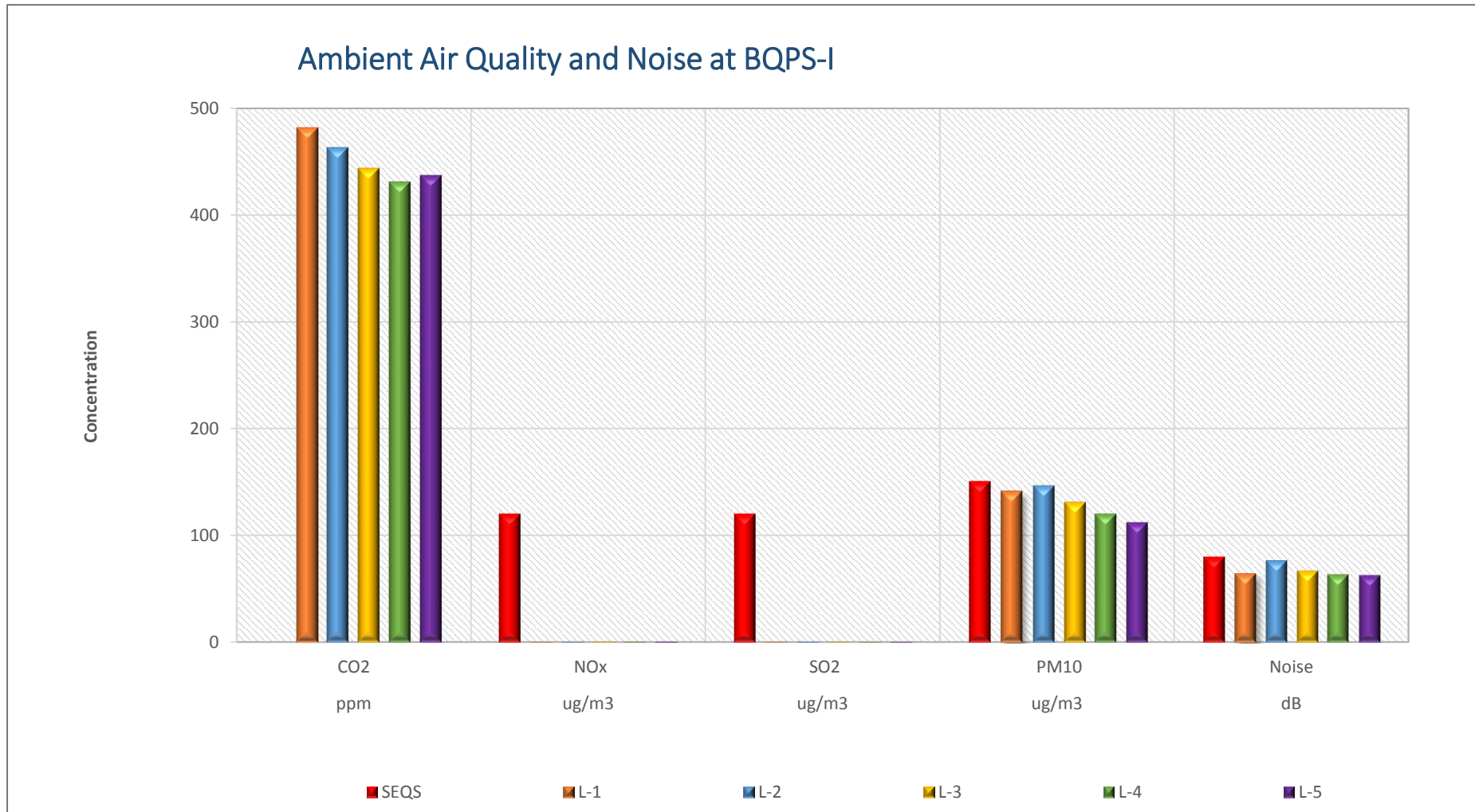
*KGS Korangi Grid Station*

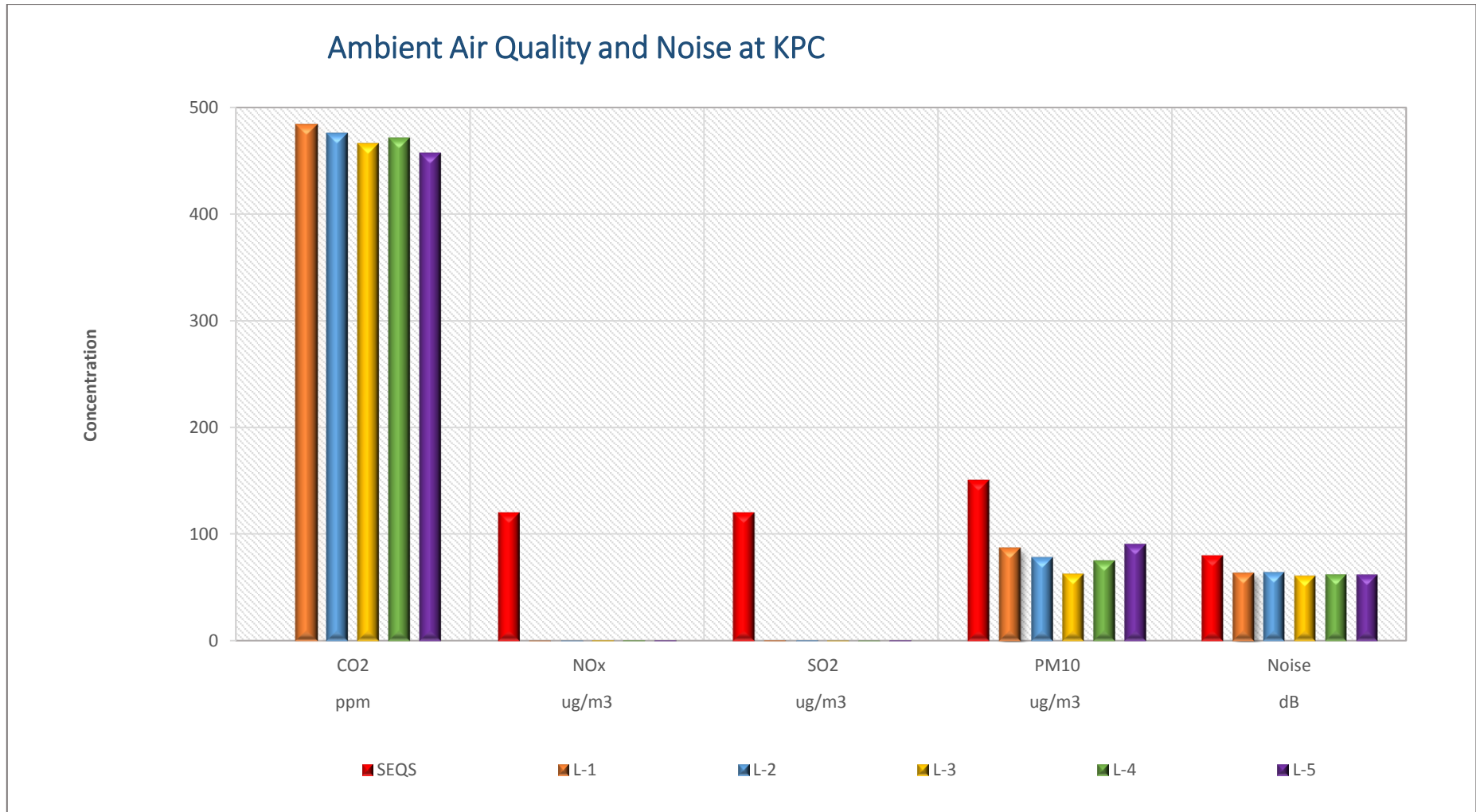
*LGS Landhi Grid Station*

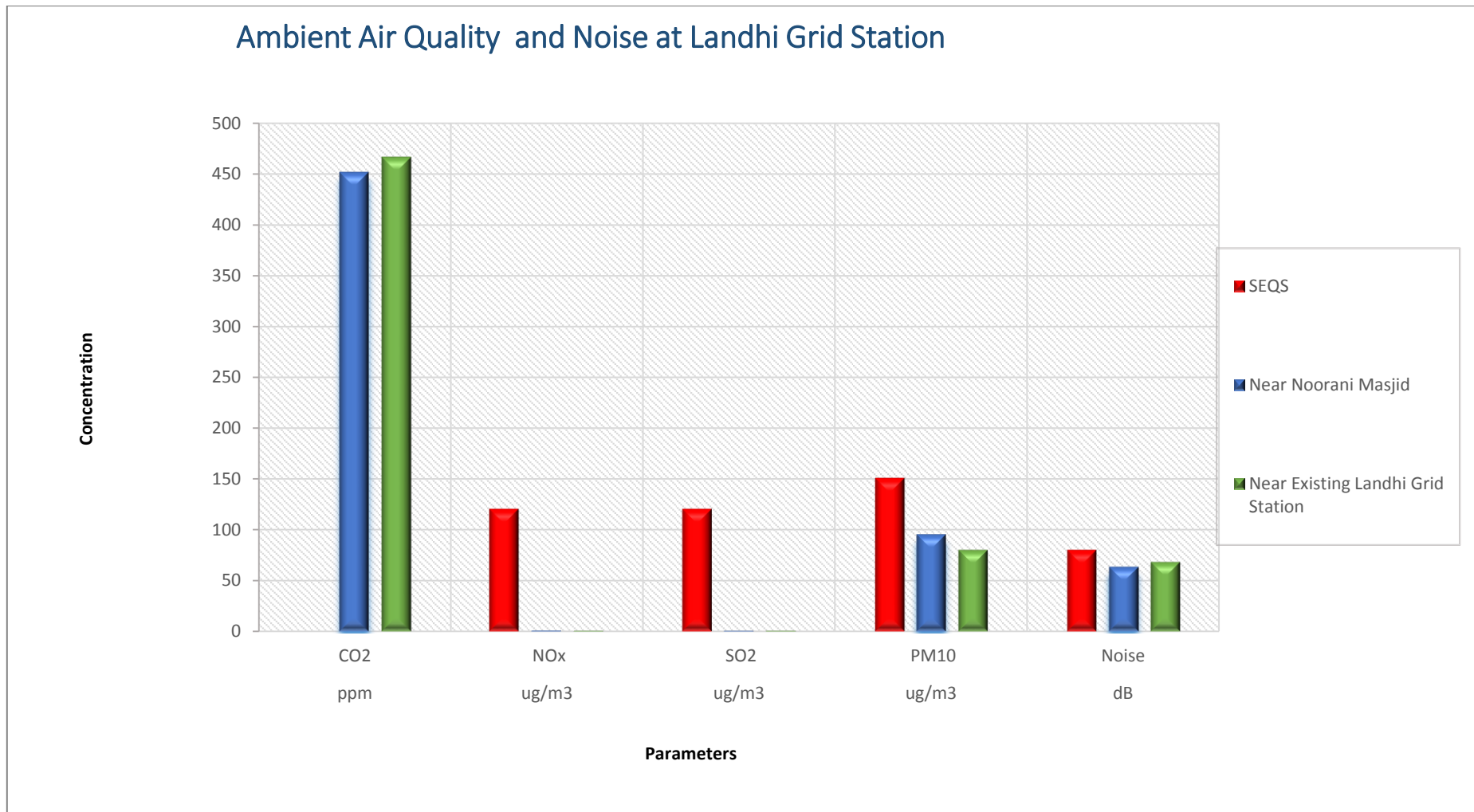
*GIS Gas Insulated Switchgear*

*KPC Korangi Power Complex*

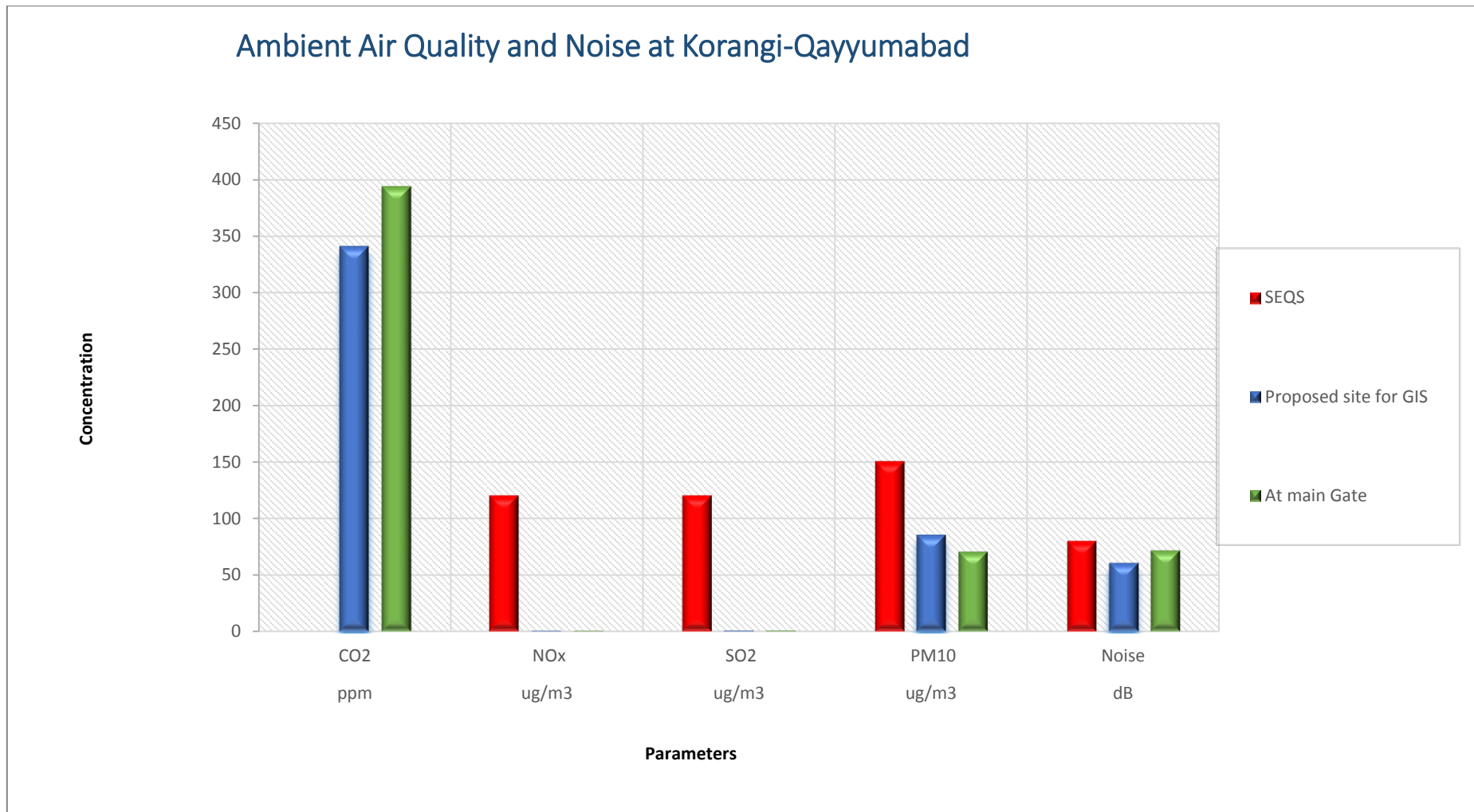
**Exhibit 4.19:** Graphical representation of Ambient Air Quality and Noise Monitoring Results at all Monitoring Locations for BQPS-III Power Project











## 4.6.2 Key Observations on Ambient Air Quality

The key observations are as follows:

- All the ambient air quality parameters monitored at five different locations for BQPS-I were observed to be within the SEQs limits
- All the ambient air quality parameters monitored at Landhi, KPC and Qayyumabad grid stations were observed to be within the SEQs limits
- One of the reasons, of relatively clean air quality within the project surrounding is fresh sea breeze, which dilutes air pollution.

## 4.7 WATER RESOURCES

This section details the water resources of the proposed project area. Both, surface and ground water resources have been summarized in this section of the report. Data was compiled from secondary sources and through field observations and data collection (EIA field survey).

### 4.7.1 Surface Water Resources

There are no significant natural freshwater sources in the proposed project area. The Indus River is about 85 km to the east of Karachi city and the Hub River lies at a distance of 60 km to the north west of Karachi. A perennial stream that originates from Balochistan and marks the boundary between Karachi Division and Balochistan are the sources of fresh water in Karachi.

The Lyari and Malir River that passes through the city do not have any natural flow, except during the monsoons. The Lyari River falls in Kemari and Malir River falls in Gizri Creek. Malir River is ephemeral and is constituted from two major tributaries i.e. Mol and Khadeji as well as some minor tributaries. Khadeji is a perennial stream that originates at Khadeji falls and gains flow as it travels across the Malir Basin.

Port Qasim lies on the inactive and western extent of the Indus delta which is largely arid and swampy; the deltaic coastline associated with Indus Delta is dissected by 17 major creeks and numerous minor creeks. The major creeks of the Indus Delta within the study area include the Phitti, Khuddi and Khai Creeks. Minor creeks, within the study area close to Port Qasim includes Korangi, Gizri, Kadiro, Issaro, Gharo, Chann Waddo and Rakhhal creek.

The Indus River had a river-dominated estuary\* but due to the increasing demand of fresh water and increasing number of dams and reservoirs the discharge of fresh water to the deltaic region became low which is critically affecting the growth of mangroves and the aquatic flora and fauna. However, the flow of fresh water increases during summer southwest monsoon season. In between 1940s and 1950s embankments were constructed on Haleji and Keenjhar lakes to divert freshwater from Indus River into these lakes and to feed the dry Gharo River. The diverted water again re-enters the intertidal

delta within the study area at a distance of 17 kilometers. The water from the Keenjhar Lake is also used for canal-fed irrigation within the eastern side of study area.

The main source of freshwater into the intertidal deltaic creeks of the study area is rain and associated runoff during the summer monsoon. The rainwater drains the land in the north of the study area and joins the intertidal deltaic creeks along the Gharo River, Malir River, ephemeral drains such as Badalnullah, Ghaggarnullah, Latnullah, and Mahyonullah, as well as wastewater drains, particularly into Korangi Creek.

#### 4.7.1.1 Drinking Water Resources

Since the key component of the proposed project lies in Port Qasim, therefore the drinking water samples were collected from BQPS-I facility and subjected to microbial and chemical analysis in the Global Environmental Lab (GEL) Pvt. Ltd. The laboratory results of drinking water are presented below in **Exhibit 4.20** and **Exhibit 4.21**.

**Exhibit 4.20:** Chemical analysis results of Drinking Water

S. No.	Parameters	Units	SSDWQ	Concentration	Method
1	pH	–	6.5-8.5	7.61	pH meter
2	Total Dissolved Solids	mg/l	1000	536	APHA 2540 C
3	Total Suspended Solids	mg/l	–	<5	Hach Method 8006
4	Chloride	mg/l	250	87.90	APHA 4500 Cl C
5	Total Hardness*	mg/l	<500	203.57	APHA 2340 C
6	Fluoride*	mg/l	≤1.5	0.62	Hach Method 8029
7	Nitrate	mg/l	<50	0.90	Hach Method 8039
8	Nitrite	mg/l	<3	0.044	Hach Method 8507
9	Sulphate*	mg/l	250	68	Hach Method 8051
10	Bicarbonate	mg/l	–	115.15	APHA 2320 B
11	Residual Chlorine	mg/l	0.5	0.06	Hach Method 8021

**Exhibit 4.21: Microbial Analysis Results of Drinking Water**

S. No.	Parameters	Recommended Value	Results
1	Total Colony Count	<500 cfu / ml	450 cfu / ml
2	Total Coliform	0 cfu / 100 ml	0 cfu / 100 ml
3	Faecal Coliform	0 cfu / 100 ml	0 cfu / 100 ml
4	Faecal Streptococci	0 cfu / 100 ml	0 cfu / 100 ml

*\*Recommended Values as per WHO guidelines for Drinking Water*

**4.7.2 Key Observations on Drinking Water Quality**

Drinking water quality at BQPS-I is fit for human consumption.

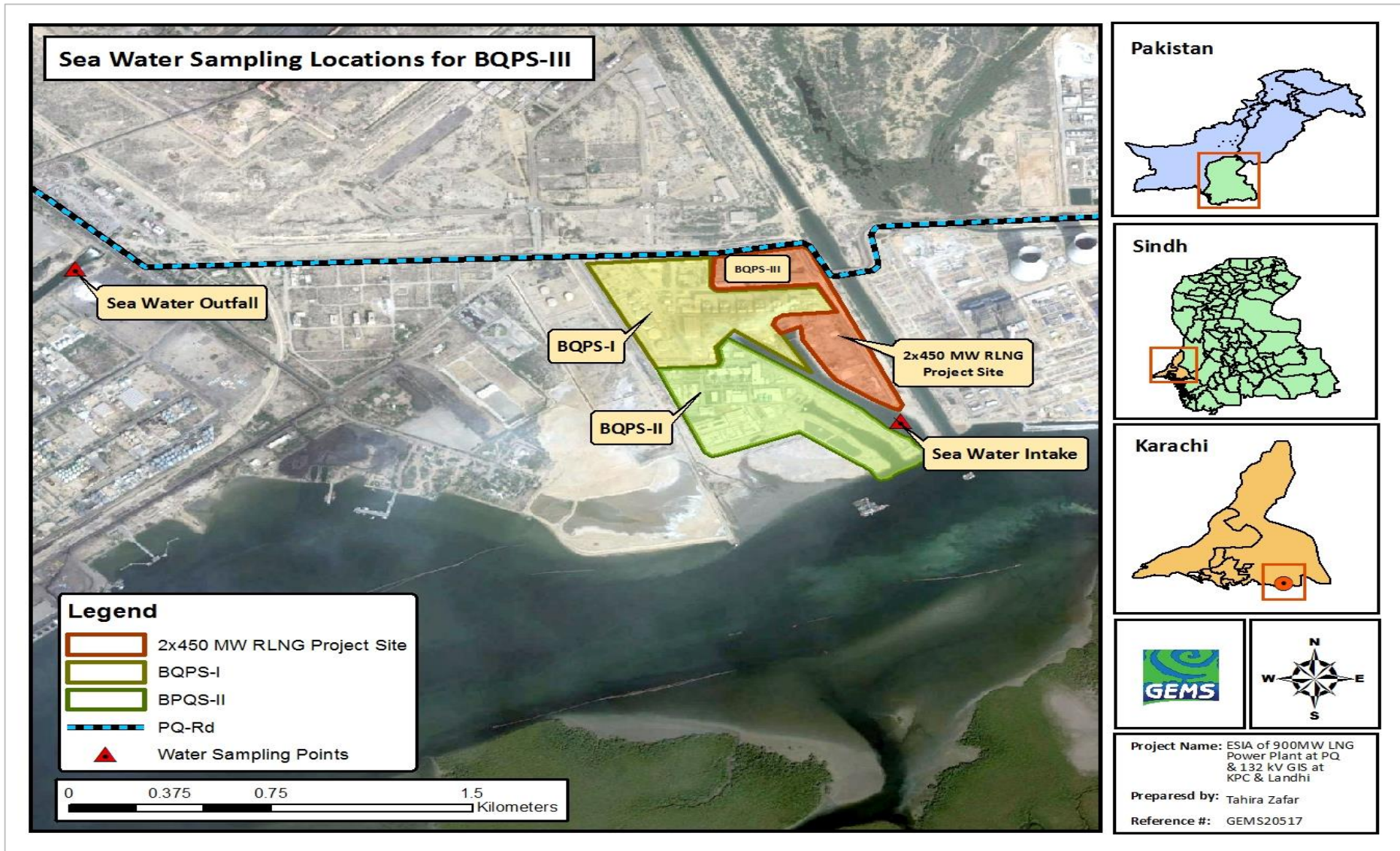
**4.7.2.1 Sea Water**

Two seawater samples were subjected to environmental monitoring and testing and both the samples were collected from BQPS-I intake and outfall channel, since the BQPS-III Power Project will fulfill its cooling water needs from the existing sea water channel. Sea water sampling location map has been presented as **Exhibit 4.23** after pictorial representation of seawater collection which has been presented in **Exhibit 4.22**, while the seawater analysis results in **Exhibit 4.24** and its graphical representation in **Exhibit 4.25**.

**Exhibit 4.22: Pictorial Representation for Sea Water Sampling**



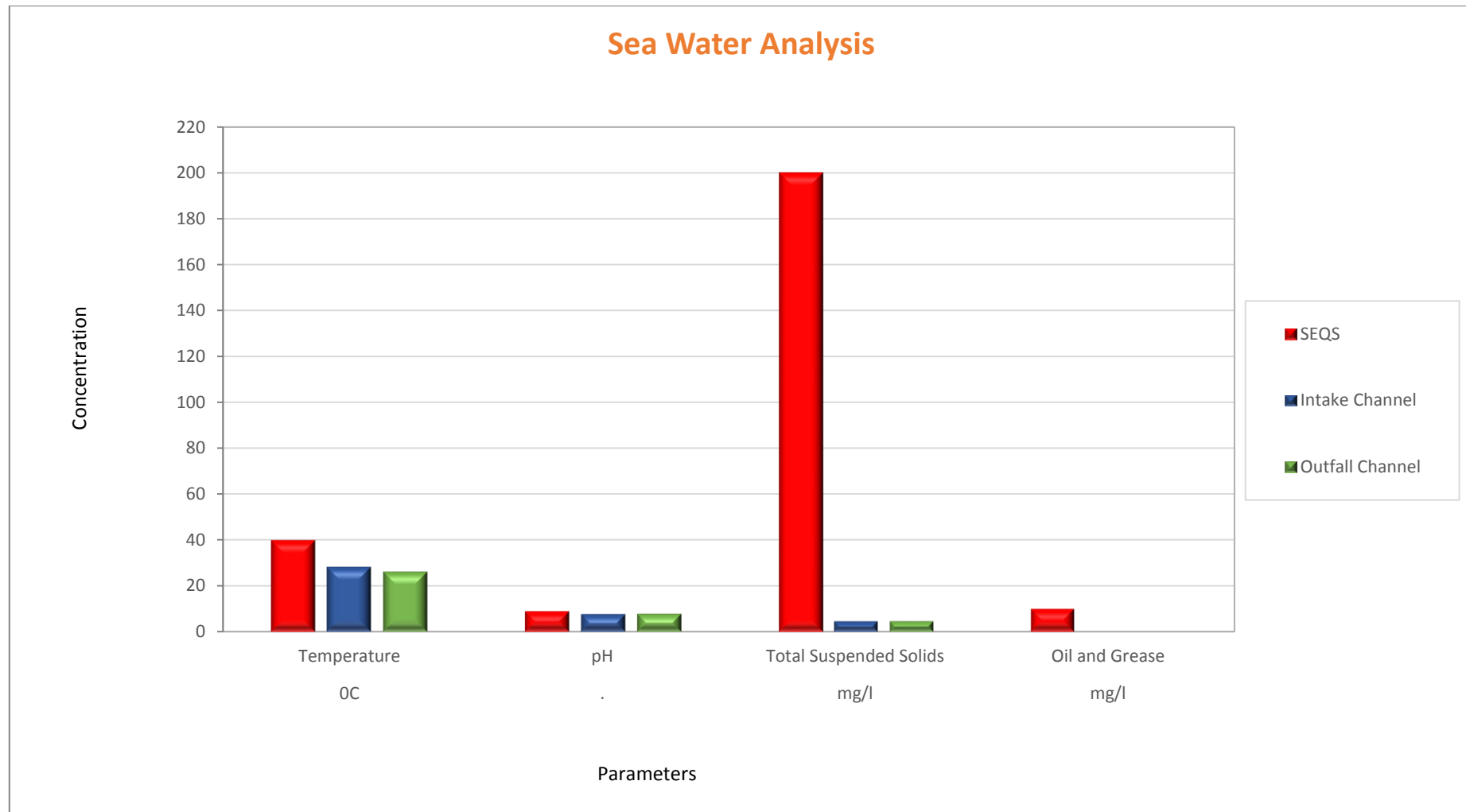
**Exhibit 4.23:** Seawater Sampling Points at Port Qasim, for BQPS-III Power Project



**Exhibit 4.24:** Sea Water Analysis Results of samples collected from Intake and Outfall Channel

S. No.	Parameters	SEQS	Unit	Concentration	
				Sea Water (intake)	Sea Water (outfall)
1	Temperature	40°C ( $\leq 3$ °C)	°C	28	31
2	pH	6-9	....	7.62	7.73
3	Oil and Grease	10	mg/l	ND	ND
4	Total Suspended Solids	200	mg/l	<5	<5

**Exhibit 4.25:** Graphical Representation of Average Concentrations of Sea Water Analysis



#### 4.7.2.2 Key Observations on Seawater Quality

Following are the key observations on seawater quality within the project surrounding

- Seawater is used for cooling the power generation units, therefore the discharge from outfall channel usually demonstrates about + 3 to 5° C variation in seawater at the time of discharge, however total length of the discharge channel also plays a significant role in temperature reduction at final discharge.
- Another factor behind elevated levels of seawater temperature is that the temperature in the Arabian Sea is strongly influenced by the monsoons.
- The highest temperature occurs around May, shortly before the southwest monsoon sets in. Temperature drops in mid-summer because at this time cold water from the deeper sea circulates near the coast
- However it is important to note at present all the parameters are within the SEQS limits, which shows that the existing power generation units have well developed systems and protocols for SEQS compliance.

##### 4.7.2.2.1 Waves

Karachi lies on the northern end of the Arabian Sea that extends southwards into the Indian Ocean for thousands of kilometers. The coast is exposed to waves from the south, southwest and west. The wave regime on the coastal belt of Karachi varies with season. It has been observed that during the winter season, when winds are around 5 m/s, the coastal waters are almost calm and during the southwest monsoon the wave height is less than 1 m, the winds are around 13 m/s and the waves on the coast are more than 3 m high. Deep sea wave data, for the southwest Monsoon months (May to September) applicable to Pakistan coast is given in the **Exhibit 4.26**.

**Exhibit 4.26:** Deep Sea Wave Data, For the Southwest Monsoon Months (May to September)  
Applicable To Pakistan Coast

Resultant Wave Height (m)	ave Period (Seconds)					Higher of Sea/Swell Height				Total
	0-3	W 4-5	for	6-7	8-9	12-13	14-15	16-17	18	
0 to 0.5	2.6%	4.1%	0.4%	0.1%	0.0%	0.0%	0.0%	0.0%	0.0%	7.4%
0.6 to 1.0	1.1%	5.3%	1.8%	0.4%	0.1%	0.0%	0.0%	0.0%		8.9%
1.1 to 1.5	1.2%	6.7%	6.3%	2.2%	0.6%	0.1%	0.1%	0.0%	0.0%	17.3%
1.6 to 2.0	0.1%	3.8%	4.9%	2.9%	0.9%	0.2%	0.1%	0.0%	0.0%	12.8%



#### 4.7.2.2.2 Tides

Tides\* along Karachi Coast are semi-diurnal but diurnal inequality is also present. The effect of this shows up in daily tidal cycle as there are two High Waters and two Low Waters which also vary considerably from each other in tidal heights. These are classified as HHW, LHW, LLW and HLW. The tides move from west to east i.e. the tide at the Hub River Coast arrives about 20 minutes earlier than Karachi. Similarly the tides at Karachi Harbour arrive at about 10 minutes earlier than entrance of Port Qasim. When tides

##### Tides\*

Tides are the rise and fall of sea levels caused by the combined effects of the gravitational forces exerted by the moon and sun and the rotation of the earth.

progress up the Phitti Creek its magnitude increases and there is time lag. The tides reach Port Bin Qasim after 22 minute which is about 20 miles from Karachi and is located about 15 miles up to creek from the sea. At Gharo Creek tides fall down rapidly due to frictional effects and the gradual weakening of the tidal forces. At Gharo 35 miles from the Phitti Creek entrance the tides are almost half of the mean sea tides at the entrance. Lowest Astronomical Tide (L.A.T) is – 0.6 m. The highest Astronomical Tide (H.A.T) at PQA is + 3.7 m while the Mean Tidal Level (M.T.L) is recorded as + 1.76 m Exhibit.

#### 4.7.2.2.3 Seawater Currents

The speed of the current is generally low, about ½ knots\*. The speed increases up to 1 knot during SW monsoon. The direction of the set is directly related with the prevailing wind system. The set is generally easterly in the SW monsoon and westerly in the NE monsoon. The slight difference in direction in the Western and Eastern part of the Karachi Coast is due to circulatory pattern of the current around gyres\* which are usually formed at the center of the sea. There is a clockwise gyre during SW monsoon and anti-clockwise gyre during NE monsoon (*Quraishie, 1988*). *Quraishie (1984, 1988)* has also observed the existence of warm core eddies in the offshore areas of Pakistan.

#### 4.7.2.2.4 Seawater Salinities

The average salinity of the sea water is in between 35 to 37 ‰ (parts per thousand) it remains constant throughout the year except in the months of monsoon. During the month of monsoon the average value of salinity decrease to 25-28 ‰ for a few days. The salinity in most of the intertidal creeks of the Indus Delta remains between 37 and 41‰ for most of the year. It drops to about 30‰ in certain creeks during the period of August to October, due to the rain. The influx of floodwater from the Indus River lowers salinity in the creeks adjacent to the river<sup>1</sup>.

### 4.7.3 Groundwater Resources

Groundwater resources in Karachi are limited. The aquifers close to the coastal belt are mostly saline and dry and this water cannot be used for drinking, domestic and agriculture purposes. Meanwhile

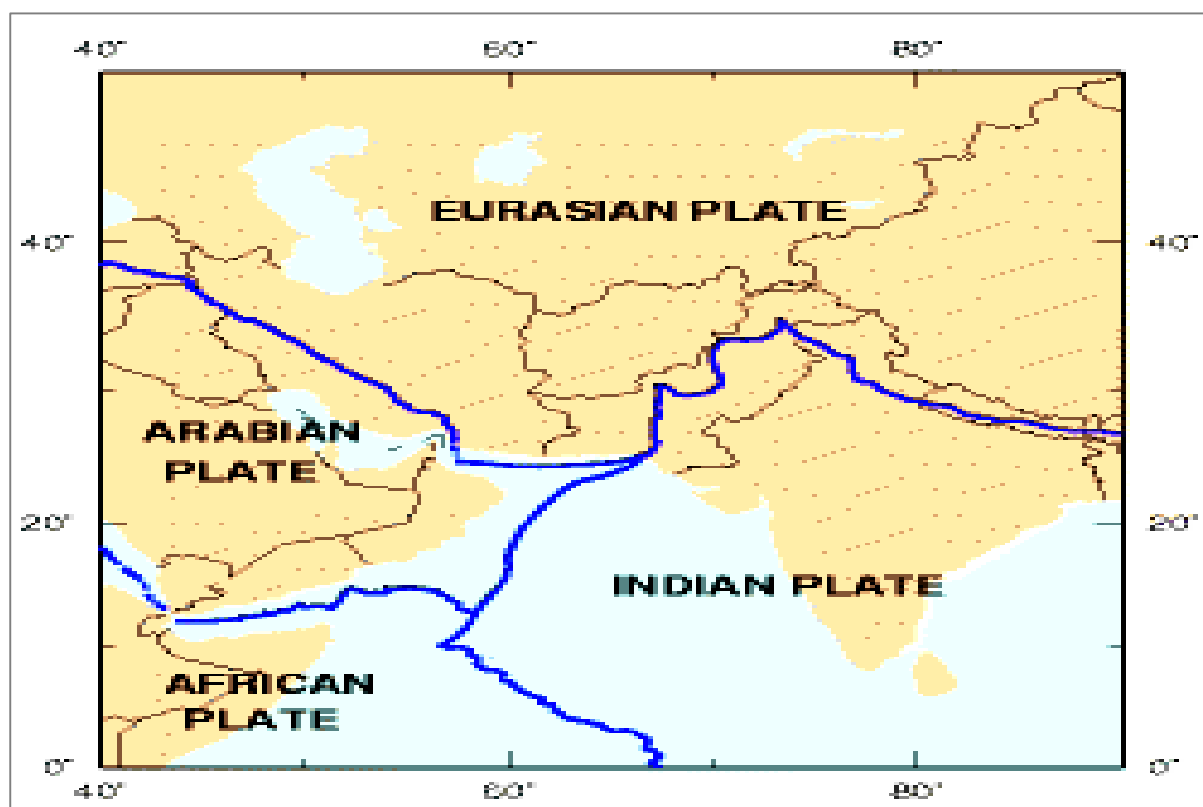
<sup>1</sup> *Cummulative Impact Assessment of Bin Qasim, Hagler Ballery Pakistan, 2016*

the aquifers which lies near the vicinity of the Hub River belt are well developed and are source of water for agriculture and other domestic purposes. Generally, the aquifers in the proposed project area are estimated to lie at depths of about 30ft to 40ft.

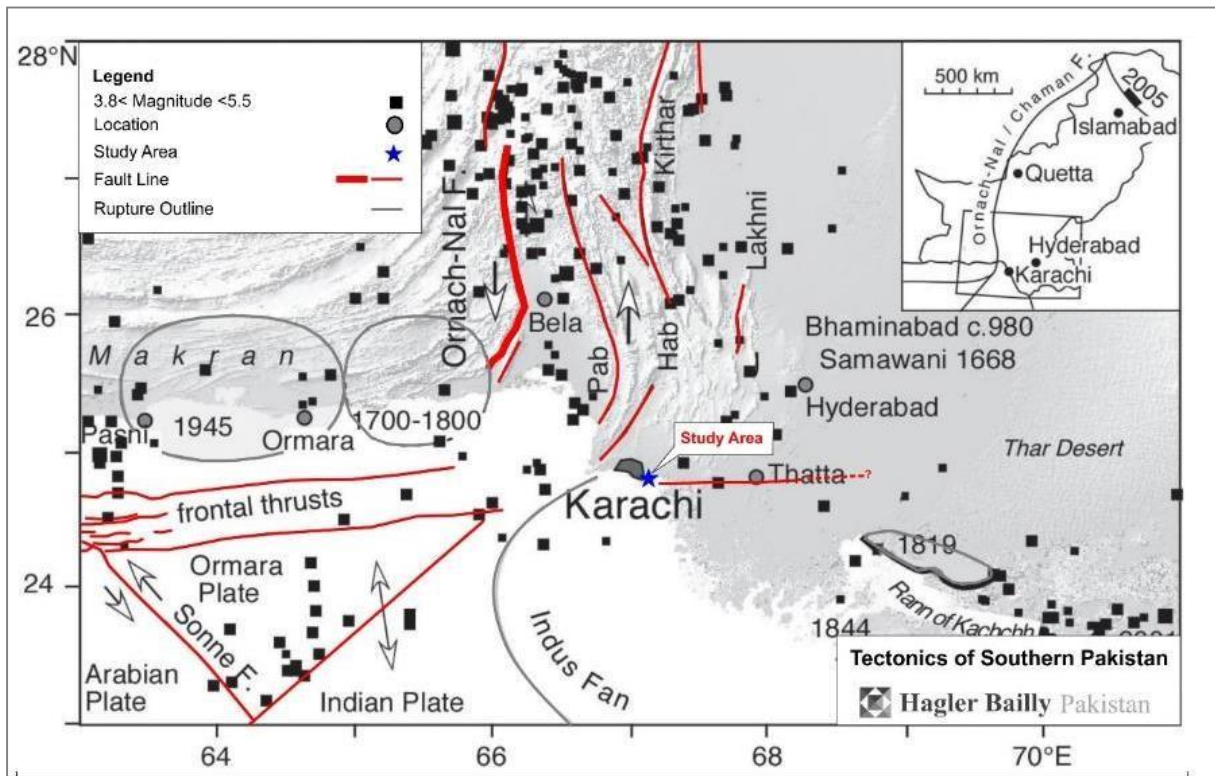
#### 4.8 FAULTS, EARTHQUAKES AND SEISMIC HAZARD

Being located close to the collision boundary of the Indian and Eurasian plates, Pakistan lies in a seismically active zone. Pakistan is located in the Indus-Tsangpo Suture Zone, which is roughly 200 km north of the Himalaya Front and is defined by an exposed ophiolite chain along its southern margin. This region has the highest rates of seismicity and largest earthquakes in the Himalaya region, caused mainly by movement on thrust faults. Seismic zone mapping of Pakistan has divided the country into four seismic zones ranging in term of major, moderate, minor and negligible zones with respect to ground acceleration values. Under this zoning Karachi Division has been identified on the edge of moderate to high hazard zone. This zone has minor to moderate damaging affect. The proposed Project Site Port Qasim is located adjacent to an active tectonic setting, and is approximately 190 km east of the triple continental junction between the Arabian, Eurasian and Indian plates. The tectonic map of Pakistan is presented in **Exhibit 4.27** Tectonics Map Pakistan, while **Exhibit 4.28** represents tectonics of southern Pakistan and **Exhibit 4.29** represents earth quake density of Pakistan respectively.

**Exhibit 4.27:** Tectonics Map of Pakistan

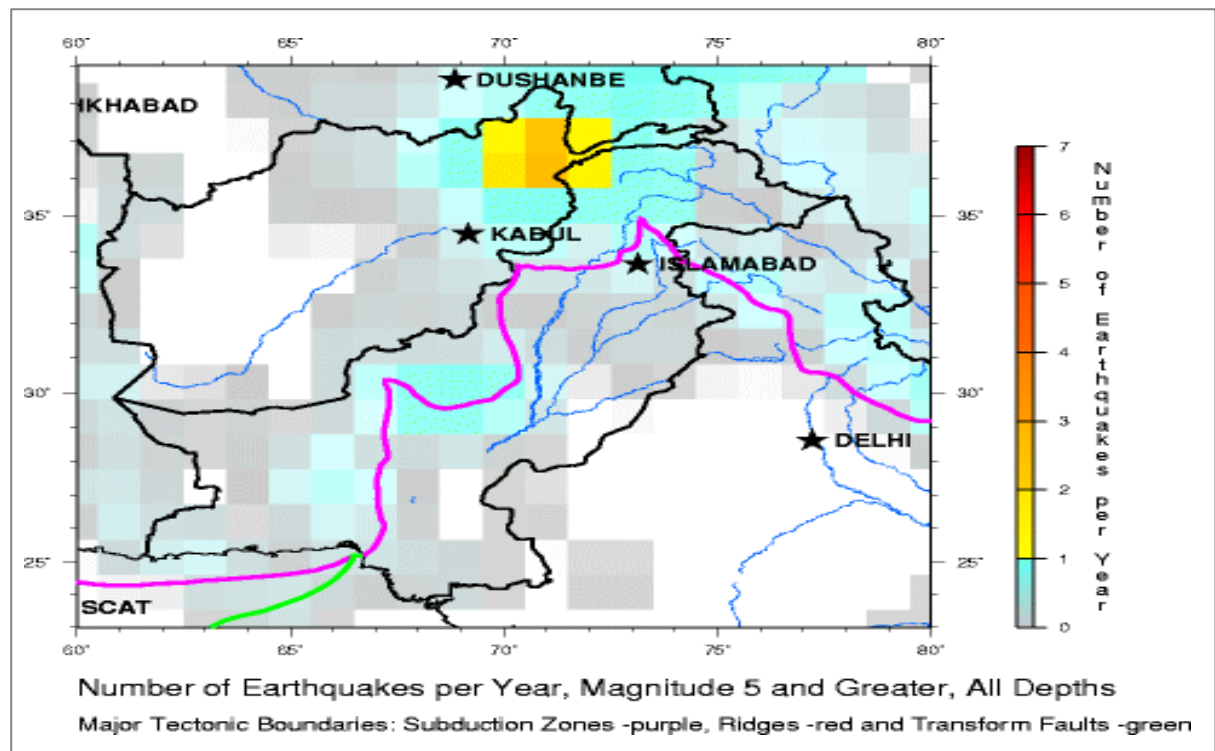


**Exhibit 4.28:** Tectonics of Southern Pakistan



Source: Cumulative Impact Assessment for Industrial and Port Developments at Port Qasim, Hagler Baley Pakistan, 2016

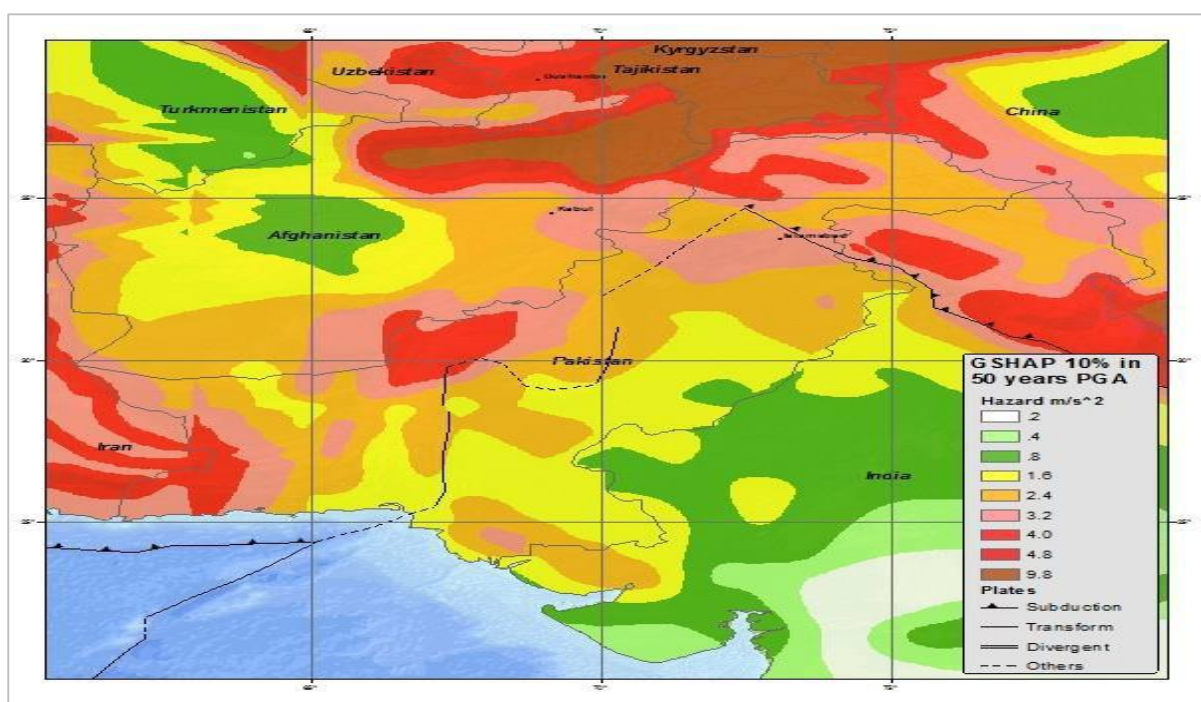
**Exhibit 4.29:** Earth quake Density of Pakistan



Source: Cumulative Impact Assessment for Industrial and Port Developments at Port Qasim, Hagler Baley Pakistan, 2016

The study area experiences an earthquake density of less than 1 Richter Scale per year. Earthquake epicenters, for magnitudes between 3.8 and 5.5 ML, have been recorded along the Pab fault, Hab fault, Ornach-Nal fault, smaller micro faults east of Karachi and in the offshore areas southwest of Port Qasim. Based on the Global Seismic Hazard Map Project (GSHAP), the peak ground acceleration (PGA) of 10 % in 50 years is  $1.6 \text{ m/s}^2$ . **Exhibit 4.30** represents seismic hazard map of Pakistan.

**Exhibit 4.30:** Seismic Hazard Map of Pakistan

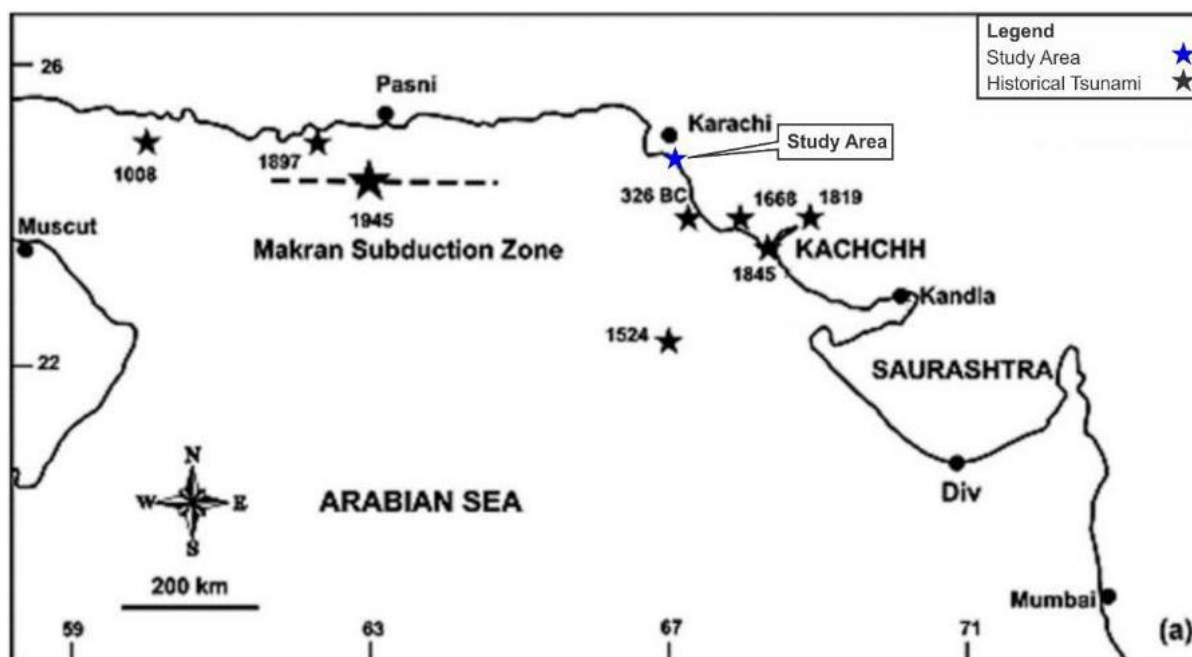


*Source: United States Geological Survey (USGS), "Seismic Hazard Map of Pakistan" (based on GSHAP), accessed 15 September 2014, <http://earthquake.usgs.gov/earthquakes/world/pakistan/density.php>*

## 4.9 TSUNAMIS

The coastal belt of Pakistan is located in an area of potential tsunami. While large tsunami genetic earthquakes have been relatively rare but there is potential for a tsunami associated with the Makran Subduction Zone (MSZ) or smaller localized tsunamis associated with several smaller thrust faults around Karachi. A map of historical tsunamis that have been generated, some in close proximity to the Port Qasim Area, is shown **Exhibit 4.31**.

**Exhibit 4.31:** Historical Tsunamis Generated In the Region (Up To 1945)



Source: Cumulative Impact Assessment for Industrial and Port Developments at Port Qasim, Hagler Baley Pakistan, 2016

Coastal areas of Karachi might experience the effect of Tsunamis as the coast line of Pakistan has had already experienced this natural hazard in the recent past. An earthquake of magnitude 8.3 generated a destructive tsunami wave in the Northern Arabian Sea and the Indian Ocean on 28th November, 1945, producing 12 m to 15 m high sea waves that killed at least 4,000 people in Pasni and adjoining areas. The tsunami hit as far as Mumbai in India. Karachi, about 450 km from the epicenter, experienced 2 m high sea waves which affected harbor facilities. Hence, the occurrence of tsunami cannot be ruled out in future. The city of Karachi lies close to potential epicenters for large earthquakes and it demands attention of the local government to enhance the capacity for managing disastrous situation, for minimizing disaster risk and response in order to reduce losses from tsunami or other climatic events. The coastal belt of Pakistan is also highly vulnerable to cyclones and associated storm surges. It has been recorded that Fourteen cyclones events had occurred between 1971 and 2001 (NDRMFP, 2007)

#### 4.9.1 Storms and Cyclones

Tropical cyclones also occur periodically in the coastal areas. These cyclones have high intensities. A total of 14 cyclones have been observed which reached the coastal areas of Pakistan since 1971 to 2001. The cyclone of 1999 in Thatta and Badin districts wiped out 73 settlements and killed 168 people and 11,000 cattle's. Nearly 0.6 million people were affected. It destroyed 1800 small and big boats and partially damaged 642 boats, causing a loss of Rs.380 million. Losses to infrastructure were estimated to be Rs.750 million. Climate change may increase the frequency and intensity of storms and could cause changes in their tracks. Although the frequency of cyclones along Pakistan coast belt is low but it can cause a huge damage when it occurs. Hence the possible occurrence of a future cyclone with severe consequences is quite rare but cannot be ruled out (NDRMFP, 2007).

CHAPTER  
**5**

# ECOLOGICAL ENVIRONMENT

## 5.1 GENERAL OUTLINE AND SCOPE

This section gives the detailed description of the ecological environmental conditions of the study area. The proposed project area under review was assessed for its potential impact on biodiversity, and ecosystem in short and long term. The data collection techniques are combination of both primary and secondary. Primary means by field verifications, observations, sampling and monitoring within the close proximity of major project installations i.e. 2 X 450 RLNG based CCGU that will be installed within the existing premises of BQPS-I and titled as BQPS-III at PQA.

However ecological baseline of the areas which requires small scale modification such as grid installations and replacements at Qayyumabad, Korangi and Landhi were also made part of this baseline investigations supplemented by secondary means of verification, which included review of published literature and previous ESIA studies, conducted by GEMS Pvt. Ltd. in the surrounding areas where small scale modifications will be made for the proposed project.

However key focus remained within the close vicinity of BQPS-III project site at PQA as the proposed project may contribute to the gaseous emissions, noise generation and heated effluent discharge during constructional and operational phase which may ultimately affect the ecology of the project surrounding at PQA, furthermore modifications associated with the proposed project in other areas are unlikely to bring about any changes within the ecological environment in its surrounding. The base line data defines and elaborates the present ecological environmental quality and features of the proposed project surrounding.

(Refer figure 1 and 2 to observe on-spot ecological baseline investigations and sampling pictures)

### KEY FEATURES OF ECOLOGICAL BASELINE

- ✓ General Habitation of Study Area under Focus
- ✓ Flora of The Study Area under Focus (Mangroves)
- ✓ Fauna of The Study Area under Focus (Macrofauna, MBI)



Figure 2: Ecological Expert Observing the Floral Species



Figure 1: Macrofauna Sampling at Project Site

Experts in the field of terrestrial ecology were engaged in the area of interest from Global Environmental Management (GEMS). The floral and faunal diversity was also determined by random sampling in and around for the area under focus. The objective of the study was to establish terrestrial and marine ecological baseline of the proposed project site and its vicinity.

Sampling locations for the identification of flora and fauna, assemblages were carefully selected so that the maximum number of species can be observed and significant ecological baseline can be generated for the proposed project area. A hand-held GPS was used to document changes in the ecological assemblages.

## 5.2 GENERAL HABITATION OF AREA UNDER FOCUS

The proposed project site is located on the northwest edge of the Indus delta system, which is characterized by long and narrow creeks, mud flats and the mangroves forest ecosystems towards the south of the plant. The present delta covers an area of about 600,000 hectares and is characterized by 16 major creeks and innumerable minor creeks, dominated by mud flats, and fringing mangroves. The coastal morphology is characterized by a network of tidal creeks and a number of small islands with sparse mangrove vegetation, mud banks, swamps, and lagoons formed because of changes in river courses.

The Gharo Phitti Creek System consists of three creeks: Gharo Creek, Kadiro Creek and Phitti Creek. All three are connected in a series starting from Gharo Creek at the north-eastern end to the Phitti Creek at the south-western end and located at 22.3 km from Karachi. This creek system is about 28 km long and its width ranges from 250 to 2,500 m. The Korangi Creek, and Kadiro Creeks are connected with it at the north-eastern end while it acts as main waterway connected with the open sea at the south-western end. However the project area also sustains Mangroves forest within its vicinity immediately after the outfall channel, the forest inhibits diverse species habitats of Marine Benthic Invertebrates, reptiles, birds, and flora. However it is important to note that the proposed project does not involve clearance of cutting of the Mangroves species within its vicinity.

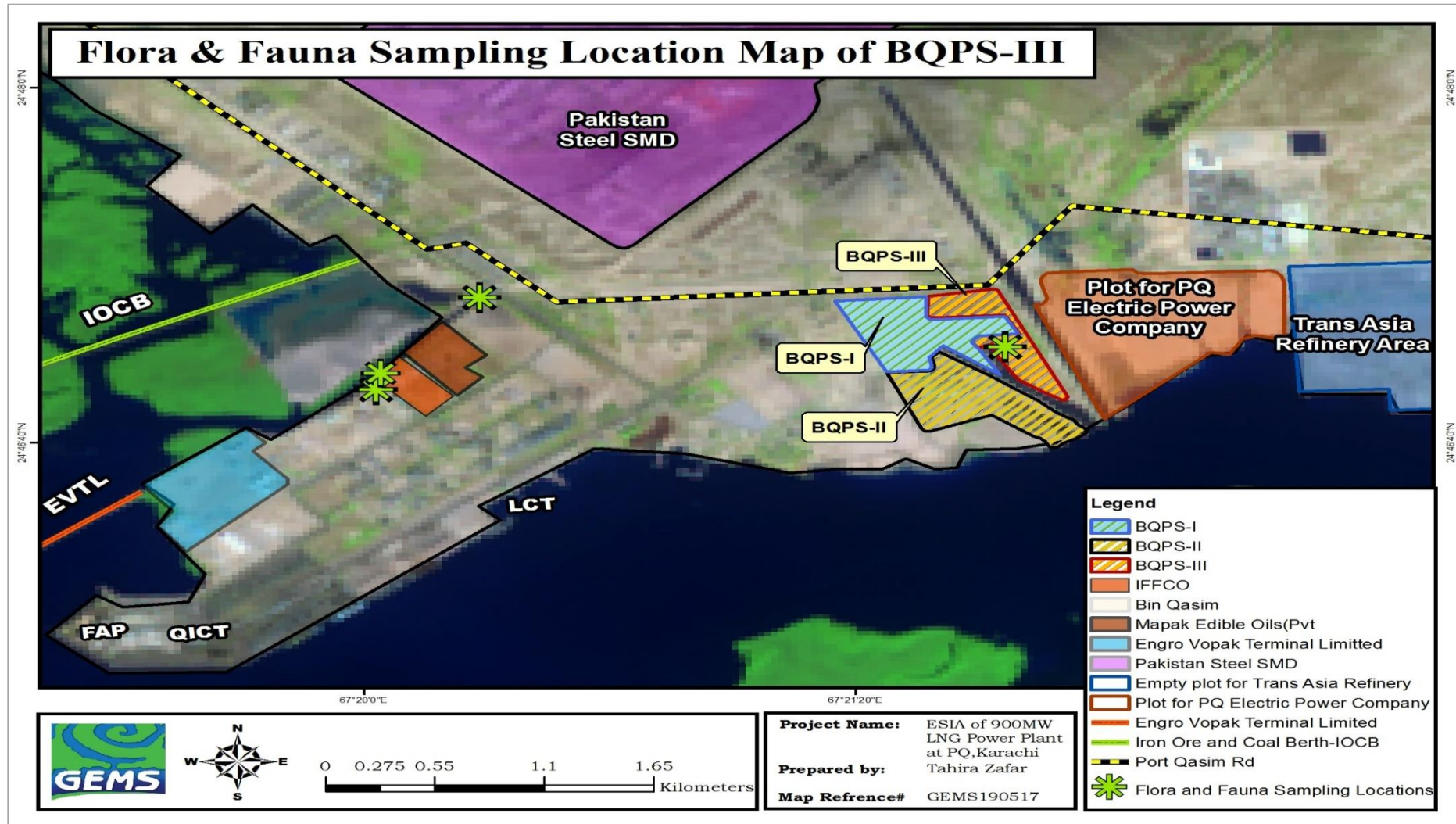
Furthermore the key area under focus for baseline establishment and other areas under modification and installation sustains a vegetation which is mostly dominated by shrubs. However variations in vegetation composition were observed with varying microhabitats. **Exhibit 5.1** represents the area under focus for ecological baseline establishment while **Exhibit 5.2** represents the flora and fauna sampling location map.

**Exhibit 5.1:** Biodiversity Study Area under Focus





**Exhibit 5.2:** Floral and faunal sampling location map.



## 5.3 FLORA OF THE PROJECT AREAS

### 5.3.1 Survey/Sampling Methodology for Mangroves:

A generic survey was carried out during the establishment of the baseline, to assess the health of Mangroves within the proposed project vicinity. According to the Sindh Forest Department, the mangroves in the area are under the control of Sindh Forest Department and Port Qasim Authority and it is declared as "**Protected Forests**".

#### 5.3.1.1 Brief Description

The PQA built area is located adjacent to the main land and has been surrounded by extensive networks of creeks system dominated by mangroves vegetation where few of the halophytic species were growing in association. The proposed project is located in Port Qasim which is part of the Indus Delta. The Indus Delta supports the seventh largest mangrove forest system in the world (WWF-P). In the Indus Delta mangrove ecosystem, eight species of mangroves have been reported out of 70 species known to occur in the tropical forests of the world. The *Avicennia marina* is the dominant species of the mangroves in the Indus Delta. Established natural or planted Mangrove habitats were not observed in immediate vicinity of the project site at both the intake and outfall channel area however, the outfall channel is lined with mangrove trees of *Avicennia marina* of >6 m in height. (Refer figure 3 & 4 to observe natural *Avicennia marina* mangroves at the outfall channel)

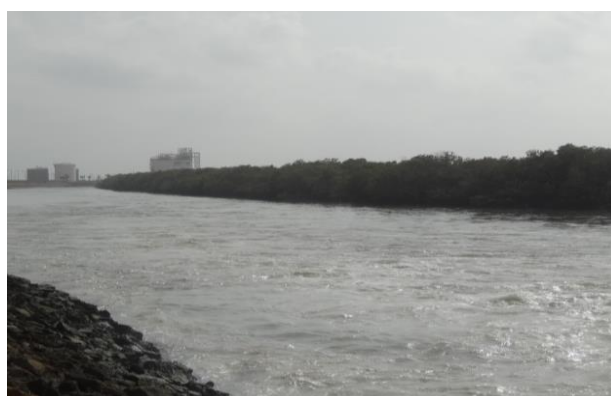


Figure 4: Natural *Avicennia marina* mangroves at the outfall channel.



Figure 3: *Avicennia marina*

### 5.3.2 Terrestrial Flora

#### 5.3.2.1 Survey/Sampling Methodology for Terrestrial Flora

The area was surveyed by adopting a plot less methodology based on ocular observations was prepared for the proposed project area.

### 5.3.2.2 Brief Description

The proposed project installations at PQA, Korangi, Landhi and Qayyumabad are in the built up area. The vegetation is dominated mostly by shrubs; however variations in vegetation composition were observed with varying microhabitats. The associated life forms consisted halophytes belonging to family *Chenopodiaceae*. The other significantly represented members of the floristic list belonged to *Poaceae*, *Asteraceae* and *Zygophylliaceae*. The terrestrial habitat in the Study Area largely consists of arid and dry plain land. Plant species reported from the area include Mesquite *Prosopis juliflora*, Indian Milkweed *Calotropis procera* and Caper Bush *Capparis deciduas* the most abundant among these, Mesquite *Prosopis juliflorais* an alien invasive species which is harvested by the locals and sold in the local timber market for fuel wood and construction of local huts. Locals graze their camels on *Mesquite Prosopis juliflora*.

The general floristic list observed at PQA is presented as **Exhibit 5.3**, while on the other hand the general floristic list observed at Landhi, Korangi and Qayyumabad is presented as **Exhibit 5.4** accordingly

**Exhibit 5.3:** Floral Species Observed in Intertidal and Terrestrial Habitat of PQA

S. No	Taxon	Family
1.	<i>Blepharis sindica</i> Stocks ex T. And	Acanthaceae
2.	<i>Achyranthes aspera</i> L	Amaranthaceae
3.	<i>Pentatropis nivalis</i> (J.F.Gmel.) Field & J.R.I.Wood	Asclepiadaceae
4.	<i>Calotropis procera</i> (Aiton) W.T.Aiton	Apocynaceae
5.	<i>Conyza aegyptiaca</i> Ait	Asteraceae
6.	<i>Launaea procumbens</i> (Roxb.) Amin	Asteraceae
7.	<i>Sonchus asper</i> Fig.	Asteraceae
8.	<i>Avicennia marina</i> (Forssk.) Vierh	Avicenniaceae
9.	<i>Heliotopium ophioglossum</i> Boiss	Boraginaceae
10.	<i>Capparis decidua</i> (Forsk.) Edgew	Capparidaceae
11.	<i>Arthrocnemum macrostachyum</i> (Moric.) C.Koch	Chenopodiaceae
12.	<i>Arthrocnemum indicum</i> (Willd.) Moq	Chenopodiaceae
13.	<i>Atriplex stocksii</i> Boiss	Chenopodiaceae
14.	<i>Chenopodium album</i> L	Chenopodiaceae
15.	<i>Salsola imbricata</i> Forsk	Chenopodiaceae
16.	<i>Suaeda fruticosa</i> Forsk. ex J.F.Gmelin	Chenopodiaceae

S. No	Taxon	Family
17.	<i>Suaeda monoica</i> Forsk. ex J.F.Gmelin	Chenopodiaceae
18.	<i>Convolvulus arvensis</i> L	Convolvulaceae
19.	<i>Cressa cretica</i> L	Convolvulaceae
20.	<i>Cyperus bulbosus</i> Vahl	Cyperaceae
21.	<i>Euphorbia serpens</i> Kunth	Euphorbiaceae
22.	<i>Alhagi maurorum</i> Medic	Fabaceae
23.	<i>Acacia nilotica</i> Delile	Mimosaceae
24.	<i>Prosopis juliflora</i> Swartz	Mimosaceae
25.	<i>Commicarpus boissieri</i> (Heimerl) Cufod	Nyctaginaceae
26.	<i>Aeluropus lagopoides</i> (L.) Trin. ex Thw	Poaceae
27.	<i>Chloris barbata</i> Sw	Poaceae
28.	<i>Cynodon dactylon</i> (L.) Pers	Poaceae
29.	<i>Desmostachya bipinnata</i> (L.) Stapf	Poaceae
30.	<i>Paspalum vaginatum</i> Swartz..	Poaceae
31.	<i>Pennisetum purpureum</i> Schum	Poaceae
32.	<i>Phragmites karka</i> (Retz.) Trin. ex Steud.	Poaceae
33.	<i>Sporobolus virginicus</i> (L.) Kunth	Poaceae
34.	<i>Rhizophora mucronata</i> Lam.	Rhizophoraceae
35.	<i>Salvadora persica</i> L	Salvadoraceae
36.	<i>Tamarix indica</i> Willd.	Tamaricaceae
37.	<i>Fagonia indica</i> Burm.f.	Zygophyllaceae
38.	<i>Zygophyllum simplex</i> L.	Zygophyllaceae

**Exhibit 5.4:** Floral species Observed at Landhi, Korangi and Qayyumabad

S. No.	Taxon	Family
1	<i>Blepharis indica</i> Stocks ex T. And	Acanthaceae
2	<i>Cocos nucifera</i> L.	Arecaceae
3	<i>Phoenix dactylifera</i> L.	Arecaceae
4	<i>Launaea procumbens</i> (Roxb.) Amin	Asteraceae
5	<i>Avicennia marina</i> (Forssk.) Vierh	Avicenniaceae
6	<i>Heliotopium ophioglossum</i> Boiss	Boraginaceae
7	<i>Arthrocnemum macrostachyum</i> (Moric.) C.Koch	Chenopodiaceae
8	<i>Arthrocnemum indicum</i> (Willd.) Moq	Chenopodiaceae
9	<i>Atriplex stocksii</i> Boiss	Chenopodiaceae
10	<i>Suaeda fruticosa</i> Forsk. ex J.F.Gmelin	Chenopodiaceae
11	<i>Suaeda monoica</i> Forsk. ex J.F.Gmelin	Chenopodiaceae
12	<i>Cressa cretica</i> L	Convolvulaceae
13	<i>Prosopis juliflora</i> Swartz	Mimosaceae
14	<i>Aeluropus lagopoides</i> (L.) Trin. ex Thw	Poaceae
15	<i>Chloris barbata</i> Sw	Poaceae
16	<i>Cynodon dactylon</i> (L.) Pers	Poaceae
17	<i>Zygophyllum simplex</i> L.	Zygophyllaceae

**Exhibit 5.5:** Pictorial Profile of Common Floral species observed at PQA, Landhi, Korangi and Qayyumabad



*Acacia senegal*



*Chorchorus depreses*



*Aerva javanica*



*Calotropis procera*



*Leucinea sp*



*Pentatropis nevalis*

### 5.3.2.3 Conservation Status

Based on information available in the ESIA's for projects in Port Qasim, Korangi, Landhi as well as Qayyumabad and literature review, no threatened or endemic terrestrial plant species has been reported from the Study Area, with an exception on mangroves at Port Qasim. The Mangrove species *Avicenna marina* found in the project area and *Rhizophora mucronanta* in the surroundings has been listed as least concern (LC), in IUCN red list of species, which endorsed its justification, as "This species is widespread and common throughout its range. It is a fast growing and fast regenerating, hardy species. It is threatened by the loss of mangrove habitat throughout its range, primarily due to extraction and coastal development, and there has been an estimated 21% decline in mangrove area within this species range since 1980. Mangrove species are more at risk from coastal development and extraction at the extremes of their distribution, and are likely to be contracting in these areas more than in other areas. It is also likely that changes in climate due to global warming will further affect these parts of the range. In addition to that according to the Sindh Forest Department, the area is under the control of Sindh Forest Department and Port Qasim Authority and declared as "**Protected Forests**".

## 5.4 FAUNA OF THE PROJECT AREA

### 5.4.1 Survey/Sampling Methodology for Coastal Invertebrate Fauna:

A field survey was undertaken by the marine environment experts on the during the month of April 2017 at project area during the onset of South West Monsoon Period. A Linear transects sampling methodology was followed using the hand-held GPS to identify the sampling station locations. A total of four sampling locations were selected to determine the baseline ecological conditions at the proposed project site. One sampling point was randomly selected at KE cooling water inlet and three sampling points at the outfall channel of the KE.

(Refer **Exhibit 5.2** to observe flora and fauna sampling points)

A digital camera was used to capture images of the marine habitats and fauna. The marine invertebrate specimens (Gastropods, Bivalves, Crustaceans, biofouling organisms etc.) encountered during the survey on exposed areas, were enumerated, documented and identified as taxonomic groups or to the genus level by referring to standard field guides.

**Pictorial view of Intake Channel  
BQPS-I**



**Pictorial view of Combine outlet  
Channel of BQPS-I & II.**



For benthic sampling (MBI), a spatula was used for sediment sampling top 10-20 cm of sediments was collected in 500 ml plastic jars. 10% neutralized Formalin was used to preserve the sediment samples for further analysis at the **CEMB research lab, Karachi University**. The macrofauna and meiofauna were separated through the 35 mm and 63 mm mesh size sieve from the sediments and preserved in 5% formalin mixed with Rose Bengal for staining of animals. The meiofauna was highly concentrated with sand particles and debris, therefore it was further diluted by making up 100 ml sample through tap water. From 100 ml sample, 10 ml sample was taken for meiofauna analysis. Samples were observed under the binocular stereo microscope and data sheet was prepared for the statistical analysis presented as **Exhibit 5.17**.

## **5.4.2 Brief Description and Findings**

### **5.4.2.1 Epi pelagic Fauna**

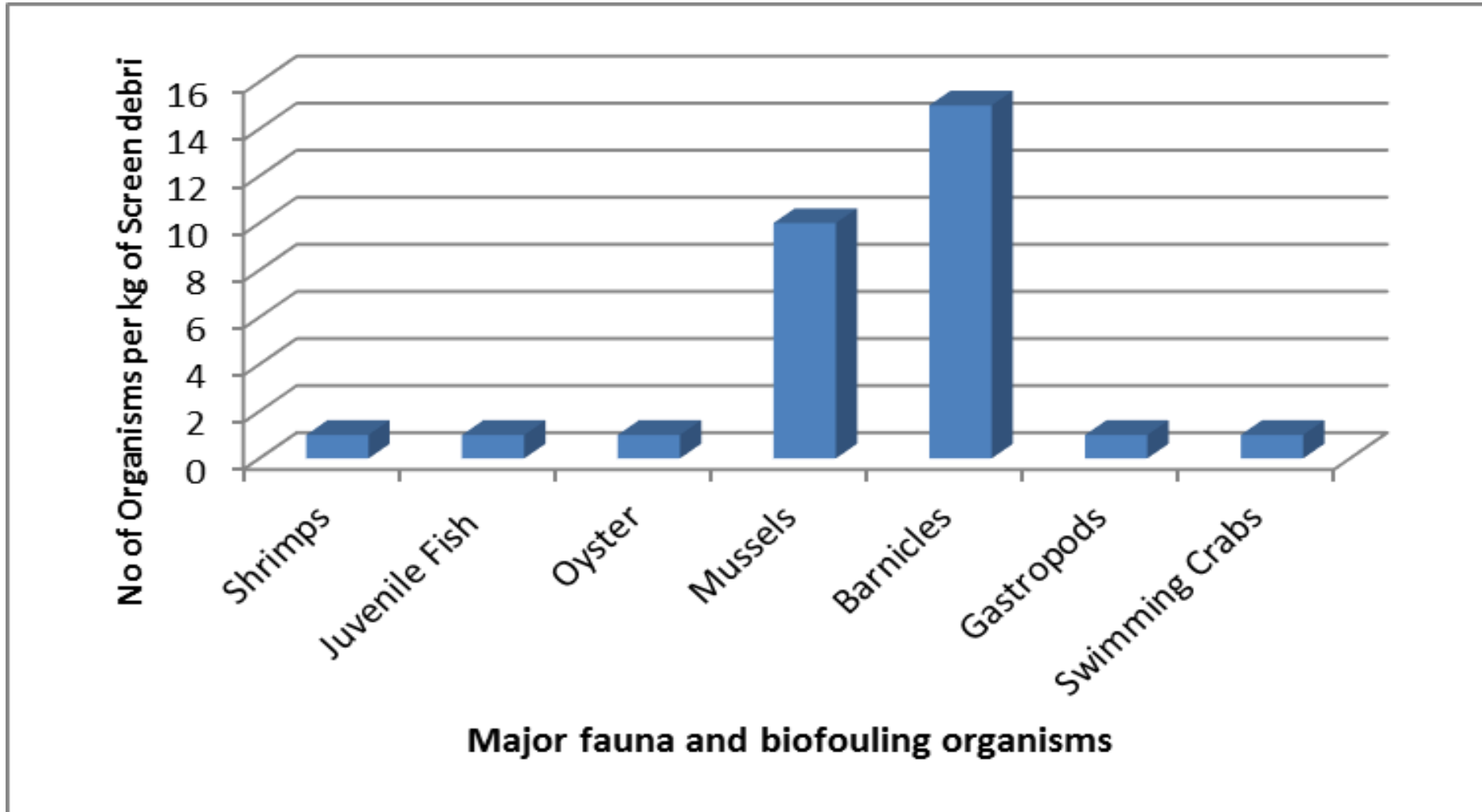
The marine invertebrates play an important role in mixing the organically enriched bottom sediments and are the key linkages in transferring the energy from lower trophic level to the next higher trophic level in the food chain.

#### **5.4.2.1.1 Epi pelagic fauna intake channel**

Approximately 230,000 m<sup>3</sup> per hour will be used as intake cooling water. The intake channel is productive in terms of benthic fauna and fish species primarily due to the fact it is a protected area and no fishing activity is allowed in the intake channel. The epi fauna observed at one sampling location of the intake channel includes juvenile fish, shrimps, swimming crabs, mussels, barnacles, oyster shells, gastropods. None of the taxonomic groups/species observed at the sampling locations are listed as endangered or near threatened or threatened under the red list published by IUCN 2014. Graph showing number of organisms at intake channel observed in per kg of screen debris is presented in **Exhibit 5.6**.



**Exhibit 5.6:** The numbers of organisms observed in per kg of screen debris at BQPS-I intake channel



#### 5.4.2.1.2. Descriptive Statistics

The epi fauna trapped in the inlet channel screen was approximately 200 Kg of fish, bivalves, crustaceans and bio fouling organisms per week, display a diversified fauna. The descriptive statistics of the faunal community is given in **Exhibit 5.10** while the pictorial profile of fauna and biofouling organism collected from the BQPS-I intake cooling screen on a weekly basis consisted of juvenile fish, shrimps, swimming crabs, mussels, barnacles, oyster shells, gastropods etc. is represented in **Exhibit 5.7**.

**Exhibit 5.7:** Descriptive Statistics of faunal community at the sampled location

Station Location	Mean Ind	Variance	Std. Dev	Std Error	Total Ind	Total Spp	Min	Max	Mean Confidence Interval
Station I-1	4.286	33.571	5.794	2.19	30	7	1	15	24.87

**Exhibit 5.8:** Pictorial Profile of Epi-pelegic Fauna Observed in the Sampling Area.



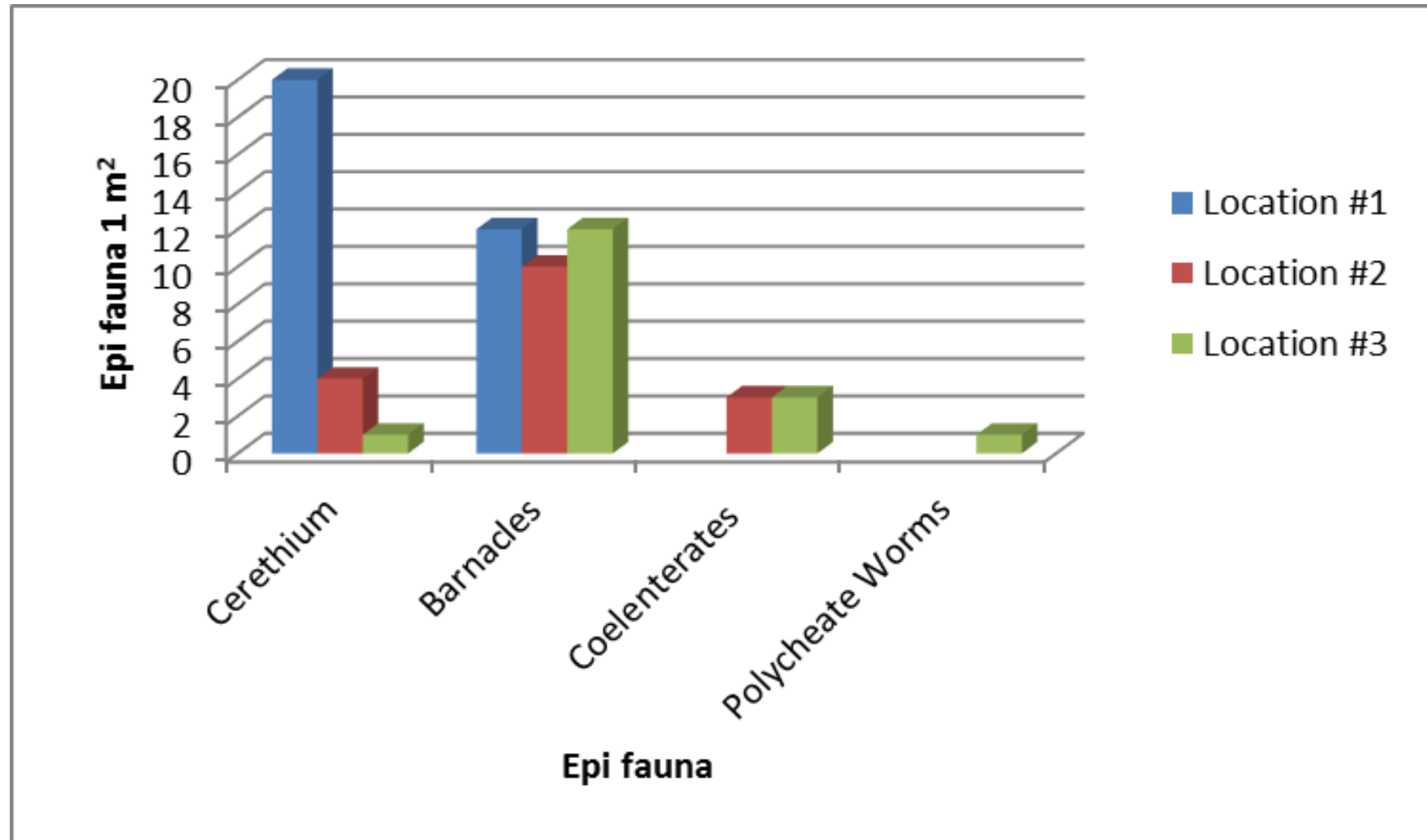
Fish, bivalves, crustaceans and bio fouling organisms trapped in the screen of intake channel of KE

		
<p>Shrimp (<i>Metapenaeus spp</i>)</p>	<p>Mussel (<i>adult</i>)</p>	<p>Juvenile fish spp</p>
		
<p>swimming crab (<i>Portunis pelagicus</i>)</p>	<p>Barnacles</p>	<p>Oyster shell</p>

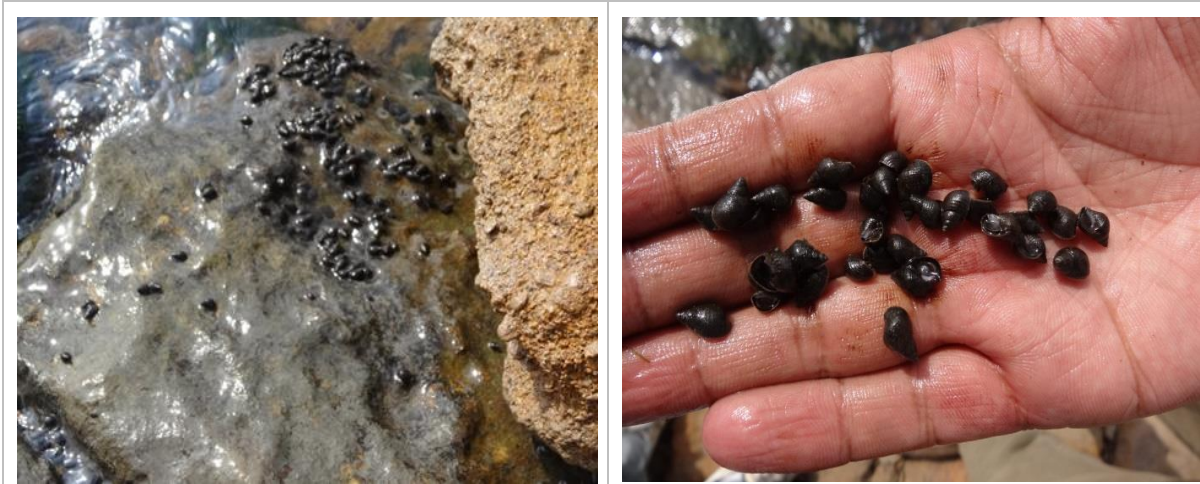
#### 5.4.2.2. Epi pelagic fauna outfall channel

The outfall channel was sampled at 3 locations at an approx. distance of 200 m from each sampling site. The epifaunal abundance observed at the outfall channel *Cerethium spp* was observed to be dominant at location # 1, the species number declined downstream at locations 2 & 3. Juvenile species of gastropods *Cerethium* were found in patches and a filamentous green microalgae was also observed. **Exhibit 5.9:** The Epifaunal Abundance Observed at the Outfall Channel of BQPS-I while on the other hand **Exhibit 5.10** represents the pictorial profile of epi pelagic fauna observed at the outfall channel.

**Exhibit 5.9:** The Epifaunal Abundance Observed at the Outfall Channel of BQPS-I



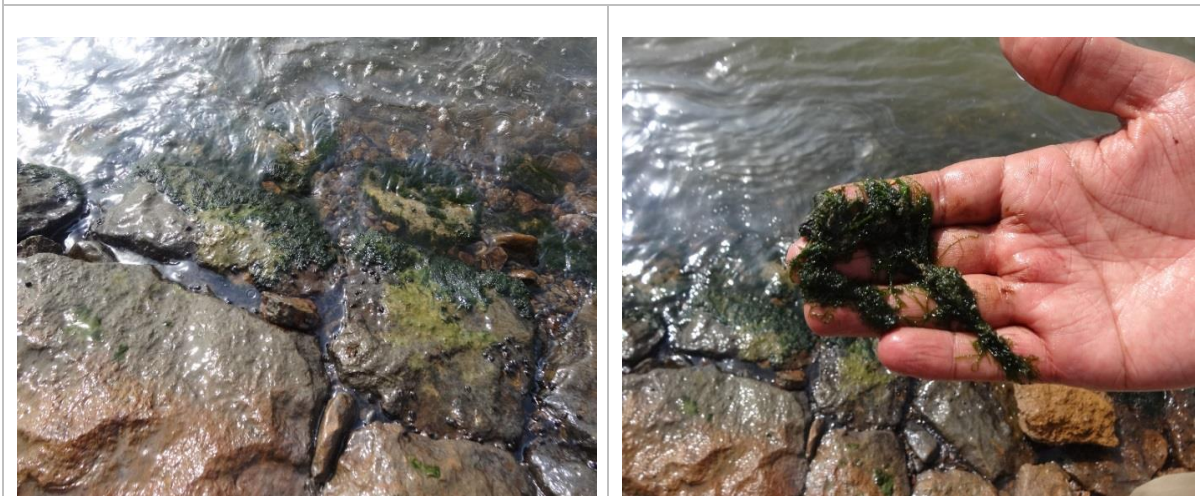
**Exhibit 5.10:** Pictorial Profile of Epi Pelagic Fauna Observed at the Outfall Channel



Juvenile of Gastropods *Cerethium*



Barnacles and Coelenterates



Filamentous Green Microalgae

#### 5.4.2.2.1. Descriptive Statistics

About 2-4 species were observed from the 3 outfall locations in the channel of the BQPS-I & II power plant. Station O-1 had the highest number of individuals representing 2 species while Station O-2 and Station O-3 had 17 individuals represented by 3 and 4 species respectively. Statistical evaluation of individuals observed at 3 locations in the outfall channel can be seen in **Exhibit 5.11**.

**Exhibit 5.11:** Descriptive Statistics of individuals observed at 3 locations in the outfall channel

Station Location	Mean Ind	Variance	Std Dev	Std Error	Total Ind	Total Species	Min	Max	Mean Confidence Interval
Station O-1	8	96	9.798	4.899	32	2	0	20	94.08
Station O-2	4.25	17.583	4.193	2.097	17	3	0	10	17.231
Station O-3	4.25	27.583	5.252	2.626	17	4	1	12	27.031

#### 5.4.2.2.2. Distribution Behavior

Coastal intertidal areas have a diverse range of communities that inhabit muddy/clay shores. The surface and burrowing marine invertebrates play an important role in mixing the organically enriched bottom sediments and are the key linkages in transferring the energy from lower trophic level to the next higher trophic level in the food chain. The marine invertebrate communities reported from the Study Area are characteristic of fine sediments from rocky to muddy/clayey. The Epifaunal species distribution (aggregate or random) is calculated for each of the species identified from the sampling stations is given in **Exhibit 5.12**.

The aggregate or random distribution is due to the mode of reproduction and bottom currents that may also be responsible for their distribution behavior. The Invertebrates epifaunal communities are restricted to top 10-15 cm of the bottom substrates. They have a relatively short regeneration (about 3-4 week) time and are quick to re-colonize. The epifaunal communities are good indicators of physical disturbance to bottom sediments or pollution related studies.

**Exhibit 5.12:** The Epi-faunal species distribution (aggregate or random)

Species	Variance	Mean	Chi-sq	d.f.	Aggregation
Cerethium	104.3333	8.3333	25.04	2	Aggregated
Barnacles	1.3333	11.3333	0.2353	2	Random
Coelenterates	3	2	3	2	Random
Polycheate Worms	0.3333	0.3333	2	2	Random

### 5.4.2.2.3. Shannon Weiner Diversity Index

Shannon Weiner diversity index is a tool for measuring the health of the ecosystem. The biodiversity values are relatively low at sample Station O-1 (0.62) at Station O-2 and Station O-3 the diversity values range from 0.959 and 0.885 respectively, (Diversity ranges from 0.1-3.0). The species Evenness ( $J'$ ) ranges from 0.639 to 0.954. The normal range for evenness ( $J'$ ) is from 0.1 to 1.0. The outfall channel is a relatively disturbed area, and therefore both species diversity and species richness are relatively low. The Shannon Weiner biodiversity Index for the outfall channel is shown in **Exhibit 5.13**.

**Exhibit 5.13:** Shannon Weiner biodiversity Index for the outfall channel

Index	Station O-1	Station O-2	Station O-3
Shannon H' Log Base 2.718	0.662	0.959	0.885
Shannon Hmax Log Base 2.718	0.693	1.099	1.386
Shannon J'	0.954	0.873	0.639

### 5.4.3. Benthic Invertebrate (MBI)

#### 5.4.3.1. Sampling methodology for MBI

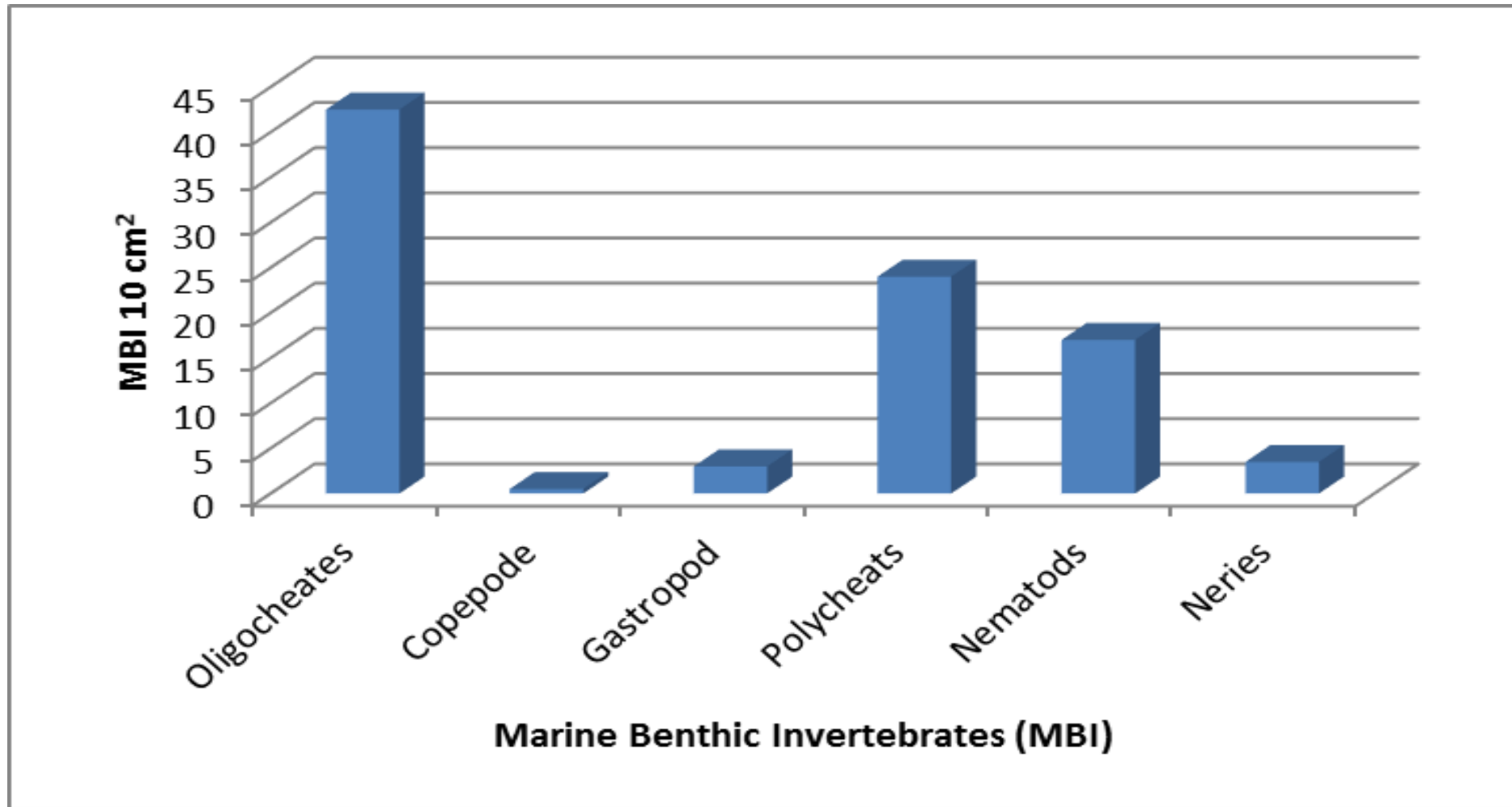
The benthic fauna (Macrofauna, Meiofauna and Microfauna) play an important role in biodegrading organic substances debris and dead material and in liberating nutrients within the sediments.

**Exhibit 5.14:** Descriptive Statistics of Benthic Fauna Observed In the Sampling Area

Outfall	Mean Ind.	Variance	Std. Dev.	Std. Error	Total Ind.	Total Species	Min.	Max.	Mean Confidence Interval
Sample 1	15.083	265.542	16.295	6.652	90.5	6	0.5	42.5	212.478



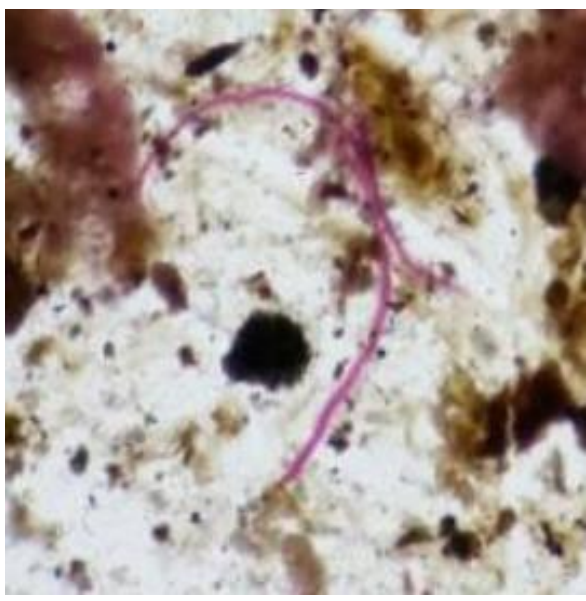

The sediment samples were greasy; there was presence of oil in the samples in the outfall drain. MBI were observed to be abundant in the benthic fauna. In macrofauna, oligochaetes (lemon color) were observed in highest number in the sample followed by Polychaete and nematodes presented below as **Exhibit 5.15**. Moreover, Copepods, Gastropods and Nereis were also present in small number in the sample which are presented in **Exhibit 5.16**. The meiofauna comprised of, nematode was observed in highest number in the sample followed by oligochaetes and forams.

**Exhibit 5.15:** Marine benthic Invertebrates observed at the outfall sampling location





**Exhibit 5.16:** MBI observed in the outfall sampling location.

	
<p>Oligochaetes</p>	<p>Oligochaetes</p>
	
<p>Nematode</p>	<p>Foraminifera</p>

#### 5.4.3.2. Conservation Status

The benthic fauna listed above are not listed as threatened, near threatened or as declining populations under the IUCN Red list of 2014.

#### 5.4.4. Survey/Sampling Methodology for Endemic Birds:

To estimate avifaunal diversity of the proposed project area individual count technique was used by using binocular spotting technique during field surveys and the identified species were immediately recorded and reported accordingly.

##### 5.4.4.1. General Description and Findings

The mangroves of the Indus Delta provide abundant food and shelter to a number of endemic species of birds Figure 16. The common birds are Oystercatcher *Haematopus ostralegus*, Lesser Sand Plover *Charadrius mongolus*, Greater Sand Plover *Charadrius leschenaultii*, Grey Plover *Pluvialis squatarola*, Golden Plover *Pluvialis apricaria*, Little Ringed Plover *Charadrius dubius*, Kentish Plover *Charadrius alexandrinus*, Sanderling *Calidris alba*, Dunlin *Calidris alpina*, Curlew *Numenius arquata*, Whimbrel *Numenius phaeopus*, Marsh Sandpiper *Tringa stagnatilis* and Common Sandpiper *Actitis hypoleucos*.

Breeding activities of a number of endemic birds have been reported in the coastal wetlands of the Delta particularly Little Tern *Sterna albifrons*, Common Tern *Sterna hirundo*, Gullbilled Tern *Gelochelidon nilotica*, Yellow legged Gull *Larus michahellis*, Lesser Black backed Gull *Larus fuscus* and Great Black headed Gull *Ichthyaetus ichthyaetus*

##### 5.4.4.2. Conservation Status

Among these birds, only Common Curlew *Numenius arquata* is listed as Near Threatened in IUCN Red List.

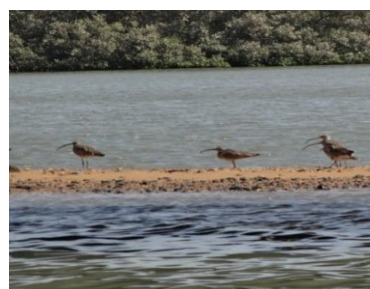
##### 5.4.5. Cetaceans

Dolphins have been sighted in the PQA area of interest and in the In the Indus deltaic region. The survey team did not observe any dolphins in the area during the boat survey. There is no published information available about the number of Cetaceans that visit the area. Similarly, the team did not find any turtles in the area nor any turtle tracks were found on the muddy shores. No turtle nest was observed. It is unlikely that the turtles would nest in muddy substrate, they prefer sandy substrates instead.

White Crane near Project Site

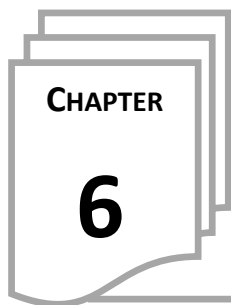


Flamingos in Flight at Proposed Project Area



## 5.5. CONCLUSION

Marine benthic invertebrates are essential for the energy transfer within the coastal ecosystem. However, they have a short reproductive life cycle, especially the marine benthic meiofauna (0.5 mm) that can quickly re-colonize a new site within a short span of about 2 – 3 weeks. None of the MBI species reported or observed in the vicinity are included in the IUCN Red List. Even though individuals are liable to be killed, the habitat loss associated with any construction activity is not likely to have a significant long-term impact on the MBI species due to their ability to re-colonize quickly.



# SOCIO-ECONOMICS & CULTURAL ENVIRONMENT

## 6.1 GENERAL OUTLINE AND SCOPE

A team of experts comprising of a sociologist and an environmental assessment specialist carried out a comprehensive study of socio-economic and cultural environment of the proposed project surrounding. The approach and methodology was a combination of primary and secondary data gathering techniques much of the secondary data was extracted from previous ESIA studies conducted in the project surrounding. This section of the report represents the assessment of the socio-economic baseline of the proposed project surrounding based on social surveys. The assessment also includes a focus on the gender aspects.

### KEY FEATURES OF SOCIO ECONOMIC ASSESSMENT

- Administrative Setup
- Demographic
- Amenities
- Health
- Education
- Livelihood
- Law and Order (Security)
- Economics

The socio-economic assessment is focused on evaluation of population, languages, literacy rate, educational facilities, health facilities, diseases, available utilities, access to social amenities, road access, availability and medium of transport, occupational statistics, water resources and basic needs of the people living in the area. However key focus remained within the close vicinity of BQPS-III project site at PQA as the proposed project may contribute to the gaseous emissions, noise generation and heated effluent discharge during constructional and operational phase which may ultimately affect the socioeconomic of the project surrounding at PQA, furthermore modifications associated with the proposed project at Korangi, Landhi and Qayyumabad are unlikely to bring about any significant changes within the socioeconomic environment in its surrounding. The information gained, helped in the measurement and determination of the impacts (positive and negative) on social services, livelihood and cultural pattern of the population under study.

## 6.2 PROJECT LOCATION AND ADMINISTRATIVE SETUP

The proposed project lies in the jurisdiction of Port Qasim Authority (PQA). PQA was established on June 29, 1973 and it is the second deep-sea industrial commercial port operating in Karachi. This Port is situated in Indus delta region at a distance of about 28 nautical miles in the south-east of Karachi. Port Qasim is geographically located on the trade route of Arabian Gulf. The port currently caters for more than 40% of seaborne trade requirements of the country. The port is engaged in providing shore-based facilities and services to international shipping lines<sup>1</sup>.

Major industrial areas in close proximity of the proposed project includes southwestern and North Western Industrial zone of PQA which houses a sizeable number of industries in its surrounding. Port Qasim Authority is the main administrative body of the town comprising of 7 UCs (Union Councils). **Exhibit 6.1** represents the administrative setup of the project surroundings.

### HUMAN SETTLEMENT SPECIFICATIONS

PQA employees residential 10 km from the proposed project site.

Pakistan Steel Mills Employees Township about 12 km from proposed project site.

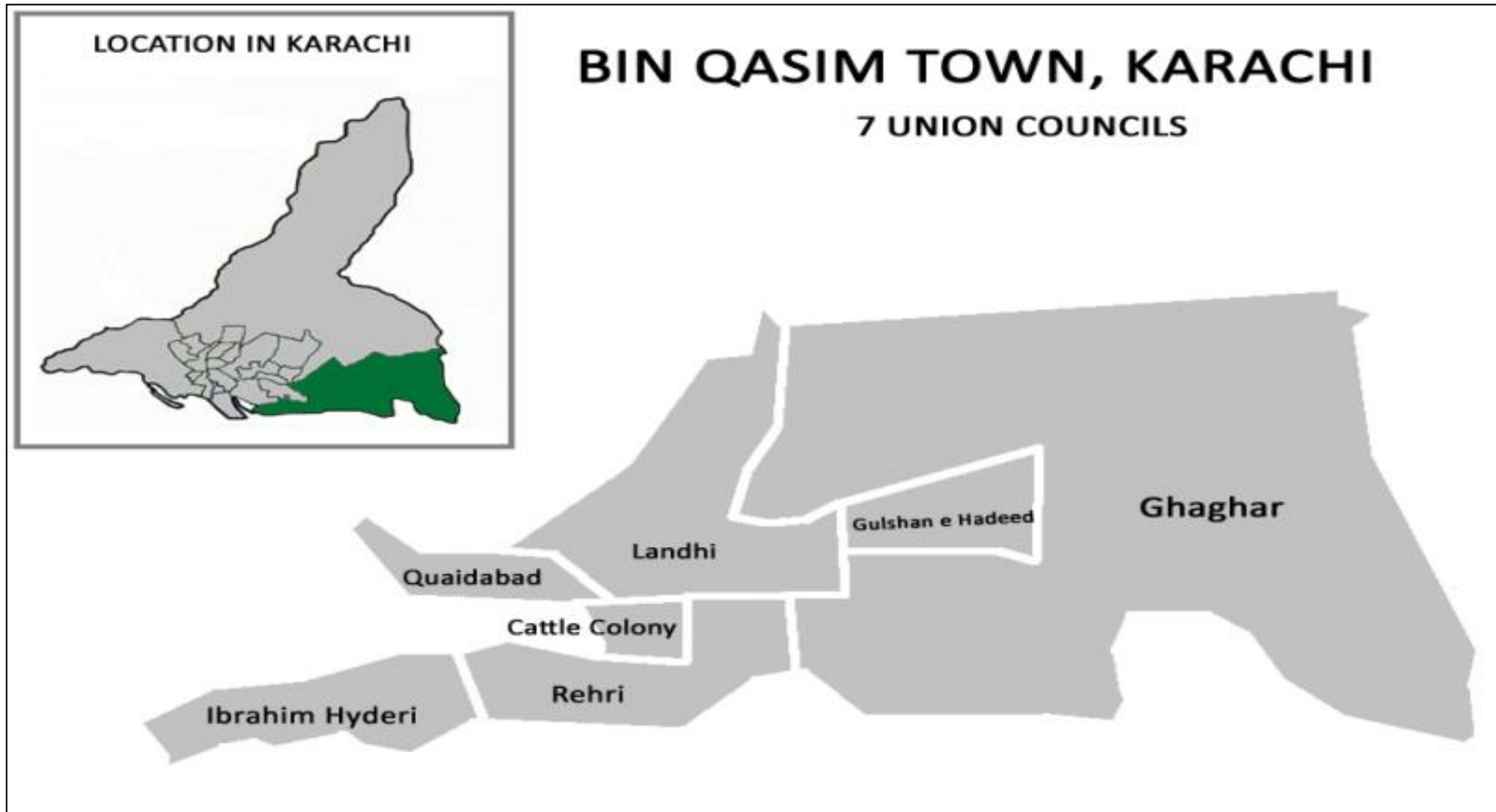
Gulshan-e-Hadeed about 12 km from proposed project site of BQPS-III.

Ibrahim Haidery about 14 km from proposed project site of BQPS-III.

Rehri Goth about 8 km from proposed project site of BQPS-III.

<sup>1</sup> <http://pqa.gov.pk/introduction.php>

**Exhibit 6.1:** Administrative Setup of the Proposed Project Area



### 6.3 TRAFFIC INLETS AND OUTLETS

The proposed project surrounding is less populated but it is rapidly growing as administrative towns of Karachi city. The local administration is working on the development and maintenance of roads and infrastructures and has led to the development of link roads and traffic networks in the city.

Considerable Major Access Routes to The Proposed Project Area		
Identification	Total Length	Status
National Highway N5	About 1819 km	Operational
Port Qasim Road	About 23.5 km	Operational

### 6.4 DEMOGRAPHICS

Karachi is reported to be the largest city of Pakistan and it is world's 5<sup>th</sup> largest city, spread over an area of 3,530 square kilometers. The city credits its growth to the mixed populations of economic and political migrants and refugees from different national, provincial, linguistic and religious origins that settle here permanently along with their families.

The population of Bin Qasim Town is approximately 1,260,000 (*Pakistan Economic Survey 2013-2014*)<sup>2</sup>. However, the population of the city is exponentially increasing with the passage of time due to the rapid developmental activities such as new residential towns are being developed to reduce the burden of overpopulation on the central city. Both upper and middle class population of the city is living near port Qasim. Gulshan-e-Hadeed and Steel Town are two main residential areas of the vicinity of the project area. Cattle colony is the center of cattle and meat trade in Karachi. Cattle Colony is the dairy products supply hub for Karachi. Small Goths such as Rehri Goth and Lath Basti sustains a major chunk of lower middle and lower class fishing communities.

#### UNION COUNCILS IN BIN QASIM TOWN

Cattle Colony  
Gaghar  
Gulshan-e-Hadeed  
Ibrahim Hyderi  
Landhi Colony  
Quaidabad  
Rehri

These communities are located about 10 to 12 km away from proposed project site on the North Western Zone of PQA, layout of (NWZ) is presented as **Exhibit 6.2**. Prominent industries like, Pakistan International Bulk Terminal Industries (PIBT) Engro Vopak Terminal Limited (EVTL), Pakistan International Bulk Terminal (PIBT), Fauji Oil Terminal Company (FOTCO) and Multi-Purpose Berths etc. are located on the South Western Zone of Port Qasim as presented in **Exhibit 6.3**. However industries such as, Trans Asia Refinery Limited, 1320 MW Coal Power Plant of Port Qasim Electric Supply

<sup>2</sup> [http://www.finance.gov.pk/survey/chapters\\_15/Highlights.pdf](http://www.finance.gov.pk/survey/chapters_15/Highlights.pdf)

Company (PQEPC), Engro Polymers, Engro Zarkhez, Tuwairqi Steel Mills Limited, KE Bin Qasim Power Station-I & II (BQPS) and Lotte Chemicals Pakistan Limited, etc. located near the project area comes under the Eastern Industrial Zone of PQA as shown in **Exhibit 6.4**. No human settlements are observed in the immediate vicinity of the proposed project as demonstrated in **Exhibit 6.5** accordingly



Exhibit 6.2: North Western Zone Layout of PQA

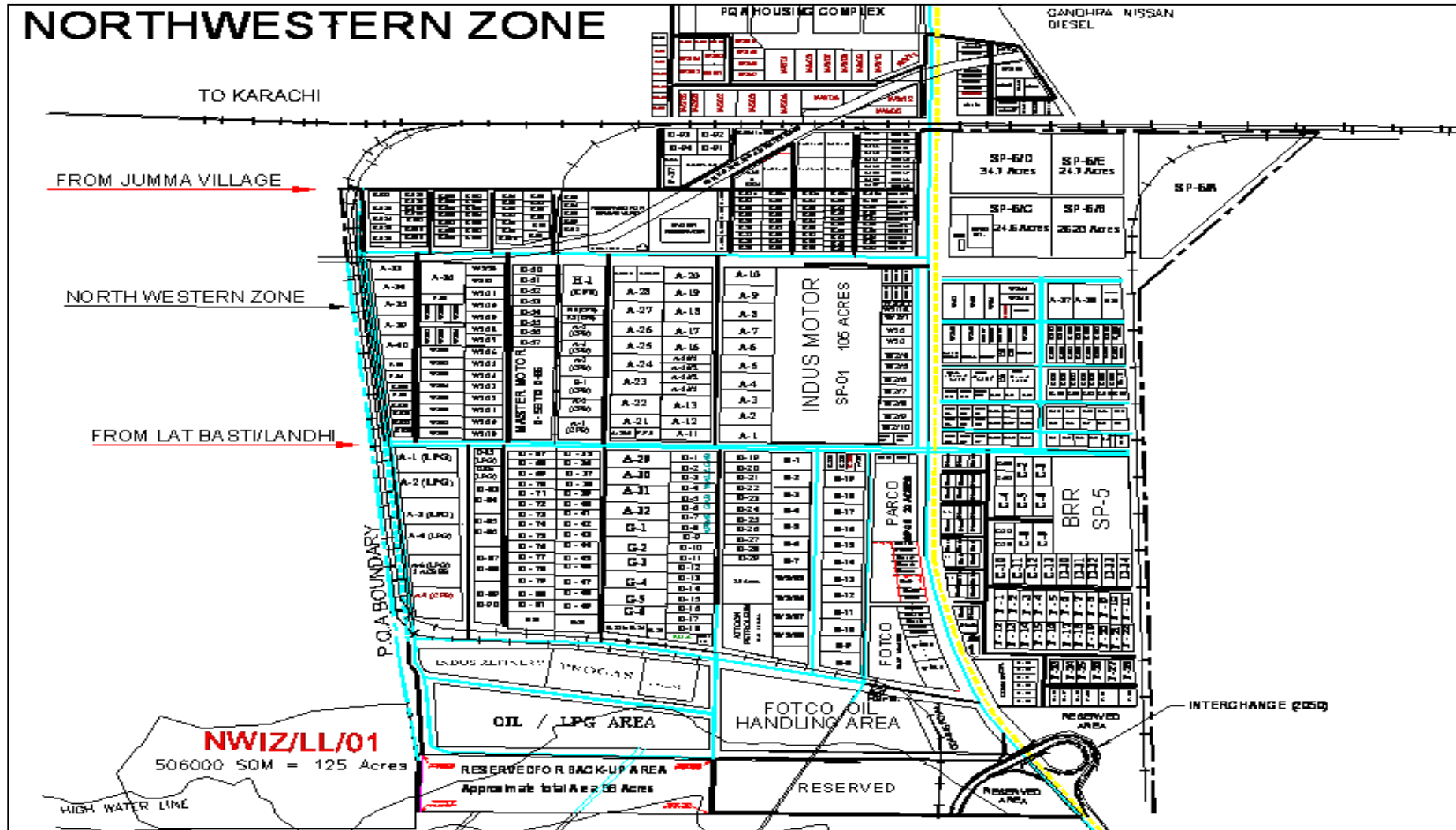
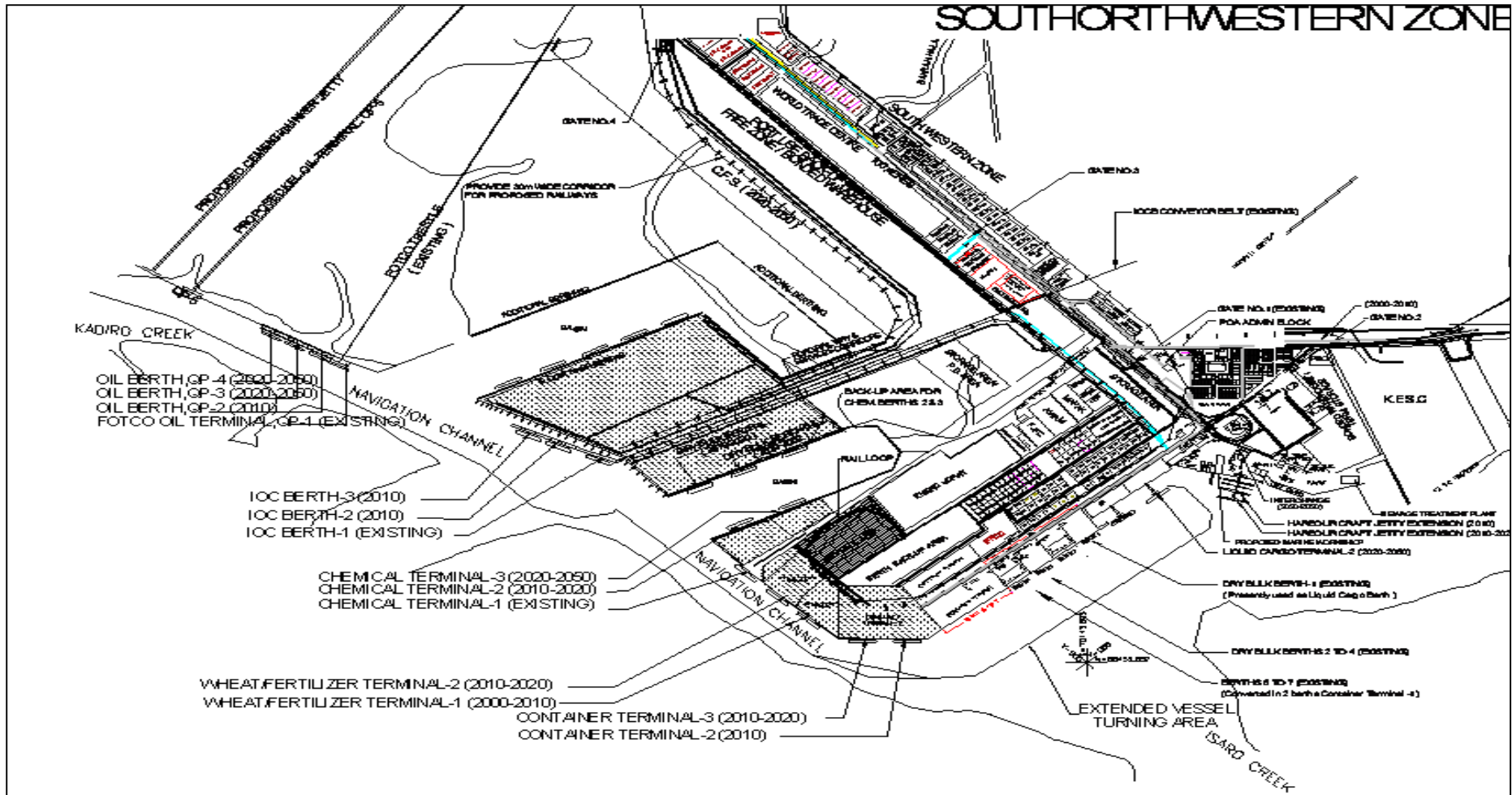


Exhibit 6.3: Southwestern Zone of PQA



Source: <http://pqa.gov.pk/uploads/image/northern-zone.gif>

Exhibit 6.4: Eastern Industrial Zone of PQA

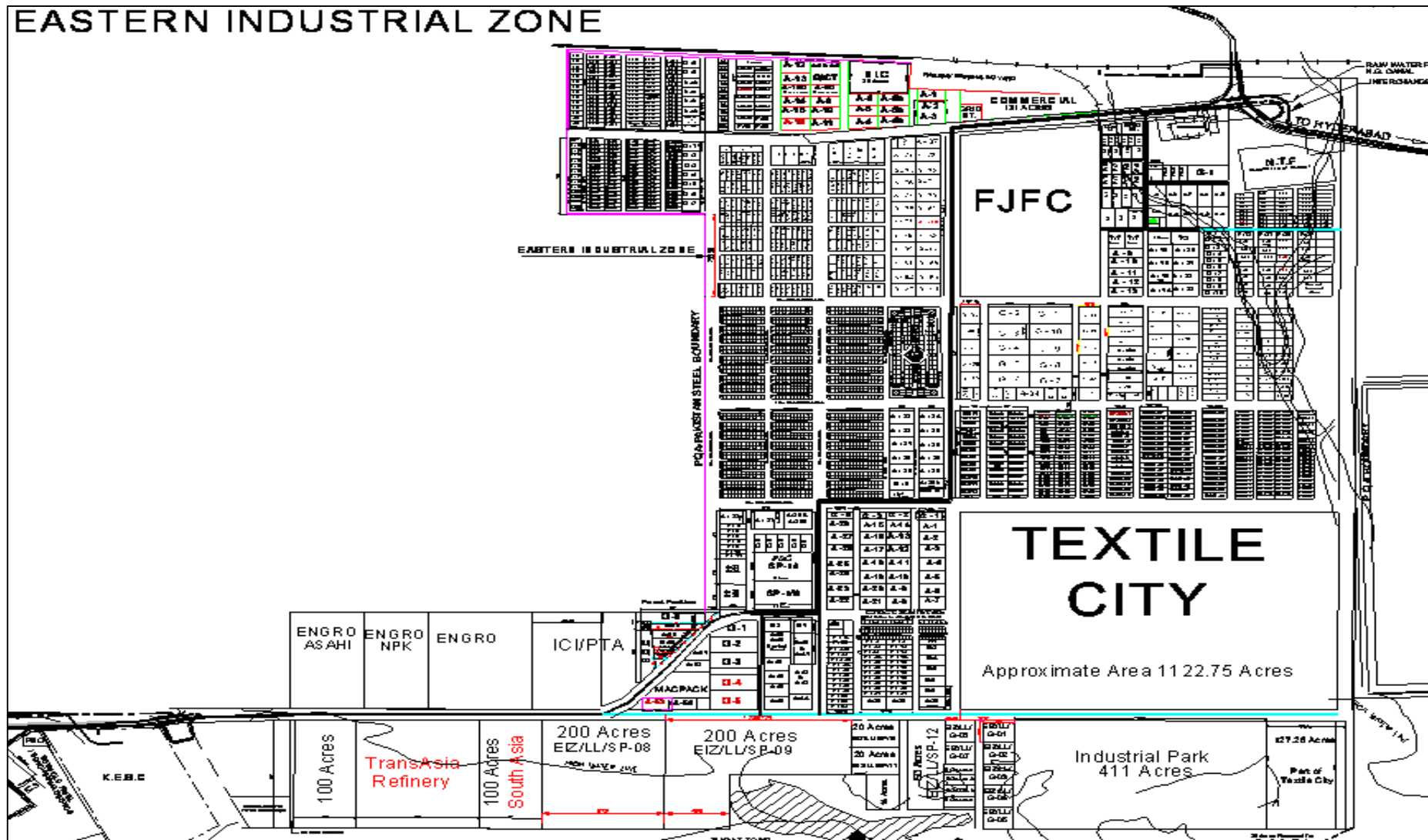
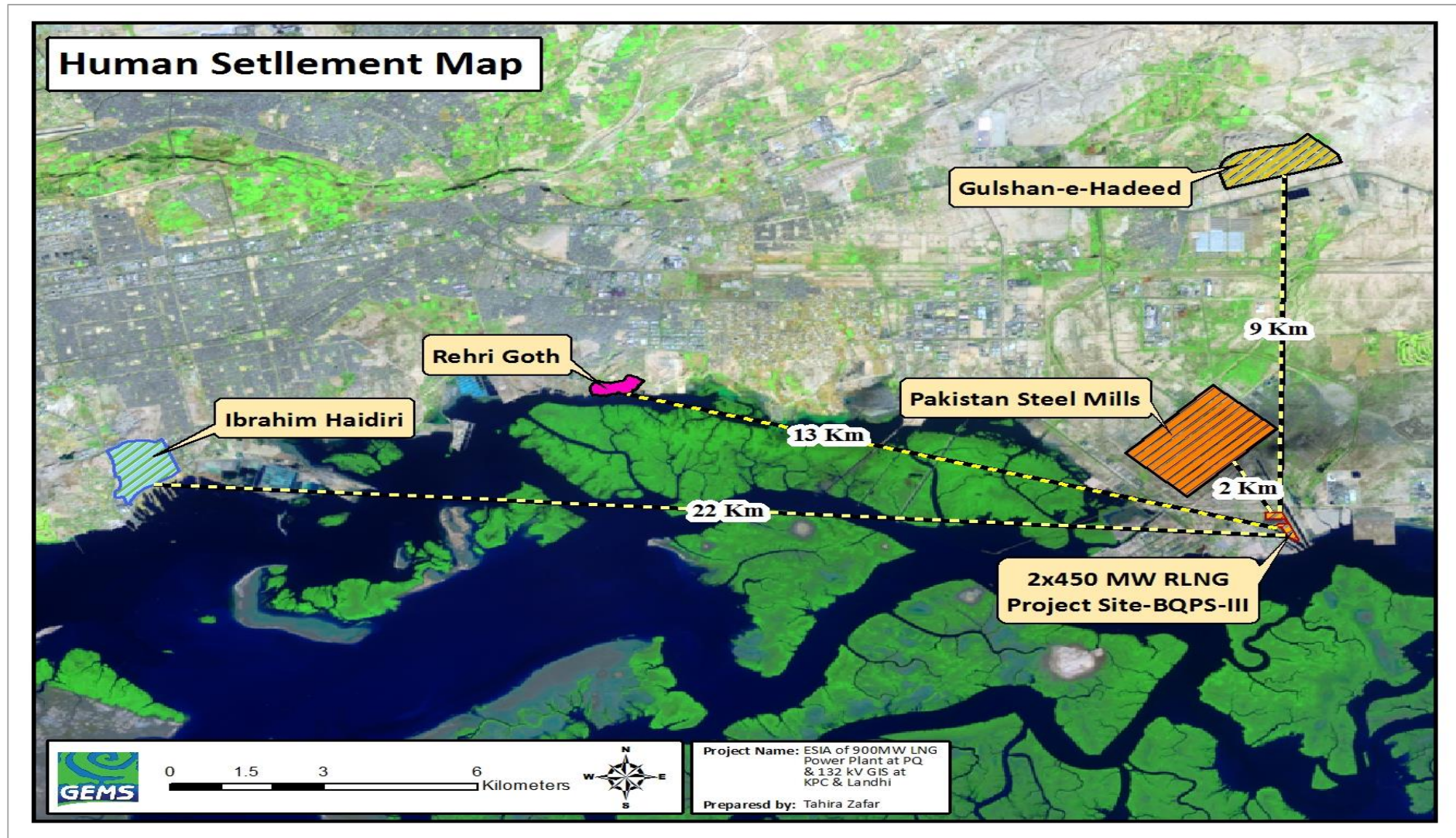


Exhibit 6.5: Human Settlement in Project Vicinity



## 6.5 NETWORKING AND BUSINESS ACTIVITIES

Key portion of the project surrounding comprises of developed infrastructure on land. Pakistan Steel Mills is one of the significant landmarks of the area, which exist at a distance of about 8 Km from the proposed project site. Apart from that PQA has launched multi-faceted strategy i.e. increase port parameters to accommodate larger vessels to benefit from economy of scales, strengthen the port with requisite crafts and build additional berths/terminal for capacity enhancement. Some of the development projects include: Deepening of navigation channel, acquisition of tugs, Establishment of 2nd Container Terminal, Grain & Fertilizer Terminal, LPG Terminal, Coal & Clinker/cement Terminal, World Trade Centre and Development of Waterfronts etc. To facilitate industrial and commercial

establishment at its industrial estate, PQA is also undertaking development of roads, provision of water facilities, sewerage, and storm water drainage in Eastern Industrial zone at a cost of Rs. 8.8 billion<sup>3</sup>. Moreover, it has been observed that Government of Pakistan is also pursuing to enhance gas production in order to meet the increasing need of energy in the country. Power sector has been given priority in terms of allocation of gas for power generation. Such kind of developments will not only promote networking and business activities in the project surrounding but will bring about a positive change in country's economy and the Cleaner Production techniques will be adopted by industry to minimize the air pollution<sup>4</sup> as the oil based power plant releases the noxious gases in environment as well as it is not the cost effective technology for the production of electricity. With concrete and sincere efforts of the government, almost 12 percent growth has been observed in real value addition of electricity generation & distribution and Gas distribution during FY 2015 and FY 2016 which in turn helped the real GDP growth of 4.7 percent during FY 2016.

### PRINCIPLE EXPORTS AND IMPORTS

#### AT PQA

Wheat	Imports & Exports
Chemicals	Imports Only
Coal	Imports Only
Containers	Imports and Exports
Crude oil	Imports Only
Furnace oil	Imports Only
Edible oil	Imports Only
Iron ore	Imports Only
Rice	Export Only
General Cargo	Imports & Exports
Cement	Export
Sugar	Import

## 6.6 LIVELIHOOD

The proposed project area sustains variety of livelihood opportunities for the residents of the vicinity as well as other parts of the city. The livelihood opportunities in the project area can be broadly classified as; the fishing and non-fishing communities.

<sup>3</sup> [http://pqa.gov.pk/port\\_qasim\\_at\\_a\\_glance.php](http://pqa.gov.pk/port_qasim_at_a_glance.php)

<sup>4</sup> <http://www.iris Punjab.gov.pk/Economic%20Surveys-New/Economic%20Survey%202015-16.pdf>

### 6.6.1 The Fishing Communities of the Project Area

Fishing communities are those who are engaged in fishing as a major source of their livelihood, these communities are located on the northwestern side of the port Qasim at distance of about 10 km away from the proposed project site. These communities are a group of diverse community who resides on the seashore of Rehri Goth, Korangi creek and Ibrahim Haidiri, most of them belong to the Baloch khaskhali tribe, and they totally rely on the mangroves forest for hunting of fish, crabs and shrimps. Ibrahim Haidiri and Rehri Goth are the two biggest fishing communities

#### ESTIMATED POPULATION OF FISHING COMMUNITIES

Village Name	Population
Rehri Goth	4450
Lat Basti	3000
Ibrahim Hyderi	150,000

Source: EIA, Global Energy Holding, 2012

of the proposed project site almost 90% of the fishing communities are directly or indirectly attached with fishing business in the form of net forming, boats and ships building, fisheries, selling fishes in the local as well as in international markets. The fishing communities are also engaged with ecotourism as many local tourists visit the creeks for recreational activities as well as for fishing, these sites are playing an important role for the nature explorer to explore the beauty of mangroves and other aquatic flora and fauna. The mangroves and migratory birds of the creeks provide fun to the visitors and nature lovers. **Exhibit 6.6** is pictorial presentation of fishing community at residence and on field while fishing.

**Exhibit 6.6:** Pictorial Presentation of Fishing Community at Rehri Goath and on Field While Fishing



Local Fisherman from Rehri Goth on Field for Fishing



Fishing Community of Rehri Goth at OtaakaAK (Local Residence)

### 6.6.2 The Non Fishing Communities of the Project Area

The communities located near the proposed project area were categorized as 'Non-Fishing Communities and belong to lower income class as their livelihood mainly depends on daily wages and labor in the industries located in PQA industrial and commercial zones, towns of Gharo, Dhabeji, and

Karachi city. On the other side, most of the people living in Steel Town belong to higher and middle income class. These people are engaged with Pakistan Steel Mills while some of the people living near the proposed project area are working on the port, the rest of the population is working in different industrial units of North-western, south-western and eastern part of Port Qasim. Livelihood of the people living in these areas is different from the residents of central city. The residents of Gulshan-e-Hadeed and other developed towns of the proposed project area are usually engaged in private and government jobs within and outside the city. The Higher Income class of the proposed project area is mostly engaged with businesses and working in private and public sectors.

## 6.7 LEADERSHIP DYNAMICS

The proposed project surrounding sustains a variety of industrial units and all the administrative matters are undertaken by PQA within the project surrounding. As mentioned earlier the proposed project surrounding sustains a number of industrial units, therefore a fully functional association referred to as Bin Qasim Association of trade and Industry (BQATI) looks after general industrial matters and affairs. This association came into existence under section 42 of companies ordinance 1984 dated February 3, 2006 with clear objectives to promote industrial activities in the area in sustainable way and to contribute positively to the economic well-being, industrial production and to advance, develop, protect, safeguard, and to promote the rights, interest and privileges of the industrialist, traders and service providers having their office and / or industries / facilities in the Bin Qasim Town, Karachi. The proposed project surrounding is less populated, hence no political or religious leadership was observed.

## 6.8 EDUCATION

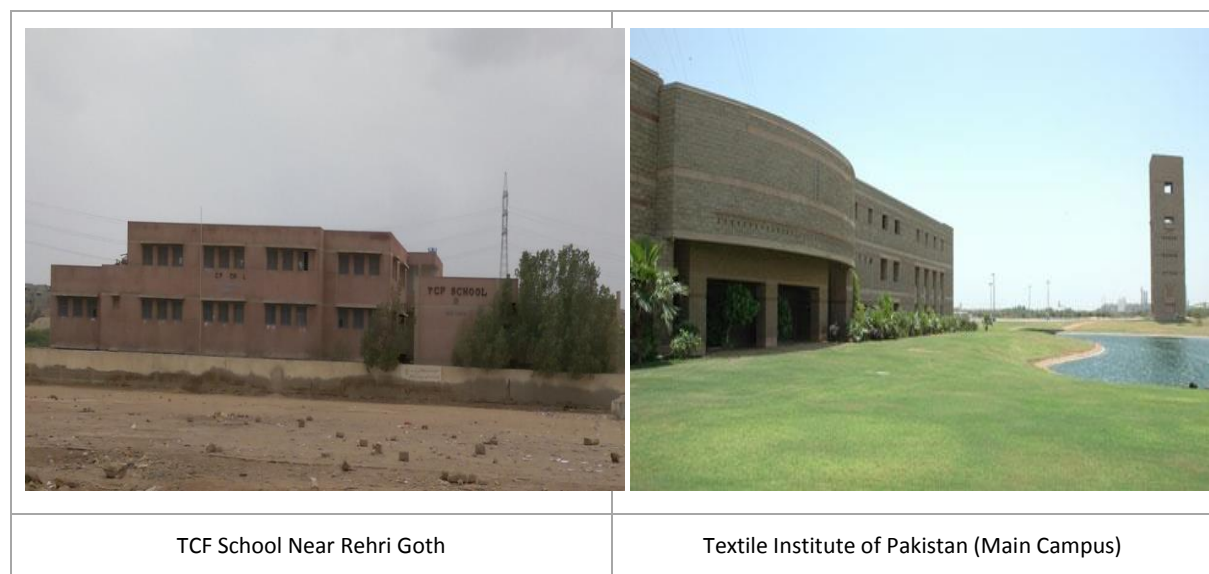
There are only few renowned educational facilities available within the project surrounding; these educational facilities are not enough to facilitate the communities of these areas. Most of the students within the project area seek higher education from central part of city.

Few renowned educational institutions in Bin Qasim Town are listed below:

- Textile Institute of Pakistan (Main Campus)
- Fast Institute (National University)
- Islamic Public School
- Askari Public School
- The Educators (Gulshan-e-Hadeed Campus)
- TCF School (Near Rehri Goth)

The educational facilities of the proposed project vicinity are shown in **Exhibit 6.7**.

**Exhibit 6.7: Educational Facilities of the Proposed Project Area**



**Note\*** None of the educational facility is in close proximity of the proposed project site

## 6.9 HEALTH

Only few hospitals and health care facilities are available within the proposed project area. In addition only one hospital is well equipped within the Bin Qasim Town namely Pakistan Steel Hospital. This hospital has a capacity of about 100 beds. This hospital can only accommodate approximately one Hundred serious patients at a time which is comparatively low as compared to the existing population of Bin Qasim Town. The hospital is located on National Highway near Steel Town, which was established to facilitate the local community. The residents of nearby Goths of the proposed project sites have only one public health facility namely Benazir Bhutto Shaheed Dispensary, which is a public facility. Other health facilities in the surrounding towns include Al-Hadeed Medical Centre, Child and Mother Clinic and Family Health Care Hospitals. Major contagious diseases in the area were observed to be GIT “Gastro Intestinal Tract Infections” and respiratory tract diseases due to the unavailability of clean drinking water and emissions of industries at Port Qasim and Pakistan Steel Mill.

Respiratory tract related infectious diseases are the major contagious disease reported in the proposed project area, this type of diseases are directly linked with the emissions from the industrial units. The people of Rehri Goth reported that they are having the epidemics of water borne, water washed and water related diseases, and these diseases are linked with the inadequate supply of fresh water in the area. **Exhibit 6.8** shows the health care facilities of the proposed project area.



**Exhibit 6.8: Health Care Facilities of the Proposed Project Area**



## 6.10 CULTURE, ETHNICITY AND RELIGION

Various cultural and ethnic groups such as Baloch, Pakhthuns, Sindhi and Punjabies are living in the project surroundings, some of the them are permanent residents of Gulshan-e-Hadeed and steel town while a major portion of the population are residing in the project vicinity due to employment opportunities. The people of the project area have adopted a mix lifestyle. Both the urban and rural establishments of the area have miscellaneous ethnic communities and multiple languages are spoken such as Sindhi, Punjabi, Pashtu and Balochi. The residents of Rehri Goth which near the proposed project site are mostly Balochi belonging to Khaskhali tribe and they speak Balochi Language.

The developing areas and Goths of Bin Qasim Town are facilitated with basic amenities especially the residents of bin Qasim and Gulshan-e-Hadeed. People of the project area have however established small communities according to their livelihood. The people of Steel Town and Gulshan-e-Hadeed represent urban life style and their way of life reflects the developed environment while on the other side, the inhabitants of Lutt Basti and Rehri Goth are urban villages and their daily routine practices resemble the Sindhi rural environment. There is a Jama masjid located by a distance of 7 km at Pakistan Steel namely Jamiya Masjid Bait ul Mukram and a famous shrine of Hazrat Hassan Shah Bukhari at Russian point Additionally it is important to note that variety of mosques and madaris are available in each society and Goths.

## 6.11 RECREATIONAL AREAS

Bin Qasim Town has a few recreational areas. Quaid e Azam Park is the only noted public recreational park of the town and this park was built in recent years adjacent to Steel Town. A large number of local people and residents from different part of Karachi visits this park and it has been noticed that on weekends the number of visitors increases. Another famous recreational point is the Arabian Sea Country Club situated in the centre of Bin Qasim Industrial Zone. This recreational

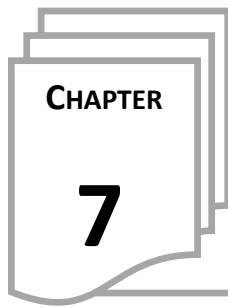


place is basically a golf club and a resort situated away from the residential areas. There are many playgrounds, small parks and gardens available within towns of the area especially Gulshan-e-Hadeed and Steel Town.

**Exhibit 6.9:** Socioeconomic Features of the Bin Qasim Town

Well Being Indicator	Name of Town / Area
	Bin Qasim Town
GPS Coordinates	25°50'05.29"N 67°21'22.67"E
Major Communities	Urdu-speaking, Punjabi, Sindhi, Pakhtoon, Balochi
No. of Houses	105000 approx.
Livelihood	Labor, business, shops, transporters, Public and private jobs
Electricity	Available
Fueling Source	Available
Major Educational Institutions	National University (Fast Institute) Textile Institute of Pakistan (Main Campus)
Literacy Rate	Low

<b>Drinking Water</b>	Tankers system, groundwater, KWSB
<b>Major Health Problems</b>	Malaria, Skin Diseases, Respiratory Tract Diseases
<b>Health Facilities</b>	Not Satisfactory
<b>Major Hospitals</b>	Pakistan Steel Hospital (100 beds)
<b>Major Needs</b>	Govt. hospitals. Modern Schools, Security, Drinking Water, Continuous Electricity
<b>Major Markets</b>	Small Markets and Shops
<b>Transport</b>	Public Transport, Motorcycle, cars, buses



# STAKEHOLDER CONSULTATION

## 7.1 GENERAL OVERVIEW AND SCOPE

The main objective of public consultation and scoping meetings is to disseminate information about the project and its expected impact on the primary and secondary stakeholders. The public consultation and participation serves as an effective tool for social interaction. This tool helps to develop the significant confidence between the stakeholders and the proposed project developer to minimize the anticipated environmental and social impacts of the project. Additionally, it is important to note that the word primary stakeholder is usually referred to those, which may be directly affected by the proposed project's activities while on the other hand secondary stakeholders refers to those who are usually affected indirectly or they have power to make decisions at governmental or institutional level. Based on the ESIA assessment procedures, a detailed scoping meeting/stakeholder consultative workshop was carried out on 26th April, 2017. The scoping meetings usually define the scope of environmental impact, which was later supplemented, by KIIs with different stakeholders. The most important objective of these consultation meetings was to determine the extent of the impact of different proposed project activities and suggest appropriate mitigation measures accordingly.

### KEY FEATURES OF STAKEHOLDER CONSULTATION

Key outcomes were derived from following sources:

- ✓ Key informant interviews (KII)
- ✓ Scoping meeting/  
stakeholder Consultative  
Workshop

## 7.2 SCOPING MEETING & STAKEHOLDER CONSULTATION OUTCOMES

As discussed earlier this section of ESIA clearly describes the issues raised by the stakeholders during different consultation meetings conducted specifically for this assignment, informal and focused group discussions with the primary and secondary stakeholders were carried out which was primarily focused on determining the perceptions of the following key stakeholders:

- Governmental departments
- NGOs
- Associations
- Industries

The overall objectives of the process were identified as follows:

- To inform and acquire feedback from primary and secondary stakeholders on proposed project activities
- To gain the consent of all the primary and secondary stakeholders for carrying out proposed project activities;
- To identify potential issues and mitigation measures;
- To incorporate stakeholders concerns in the project documents
- To identify the negative impacts due to the project execution

List of stakeholders consulted during the scoping meeting and KIIs is presented as **Exhibit 7.1**.

**Exhibit 7.1: List of Participants of Stakeholder Consultation Workshop**

**List of Participants of Scoping Meeting Conducted on 26<sup>th</sup> April, 2017**

S. No	Name	Designation	Organization
1.	Dr. Sami uz Zaman	Chairman	Global Environmental Management Services (GEMS) Pvt. Ltd.
2.	Dr Shahid Amjad	Marine Biodiversity Expert	Institute of Business Management (IOBM)
3.	Mr. Rafi Ul Haq	Consultant Ecologist	Coastal Restoration Alliance for Biodiversity (CRAB)
4.	Mr. Imran Sabir	Deputy Director Technical	Sindh Environmental Protection Agency (SEPA)
5.	Mr. Saleem uz Zaman	Chief Executive	Global Environmental Management Services (GEMS) Pvt. Ltd.
6.	Mr. Chandar Parkash	General Manager – HSE G&T	K-Electric (KE)
7.	Mr. Fattah Moin Jah	Manager Strategic Planning & Business Development Department	K-Electric (KE)
8.	Mr. Jibran Khalid Kidwai	Sr. Environmental Specialist & Project Coordinator	Global Environmental Management Services (GEMS) Pvt. Ltd.

S. No	Name	Designation	Organization
9.	Muhammad Zeeshan Siddiqui	Deputy General Manager Strategic Planning & Business Development Department	K-Electric (KE)
10.	Mr. Mansoor Akram	Deputy Director	K-Electric (KE)
11.	Mr. Muhammad Tahir Qureshi	Senior Advisor	International Union for Conservation of Nature (IUCN) Pakistan
12.	Engr Kashif Noor	Sr. Environmental Engineer	Global Environmental Management Services (GEMS) Pvt. Ltd.
13.	Ms. Sharmeen Shafique	Information Officer	National Forum for Environment & Health (NFEH)
14.	Mr. Shoaib Abdul Razzak	Conservation officer	World Wildlife Fund (WWF) PAK
15.	Ms. Ayesha Sufyan	Conservation officer	World Wildlife Fund (WWF) PAK
16.	Dr. Nuzhat Khan	Principle Scientific Officer	National Institute of Oceanography (NIO)
17.	Mr. Anwar Ali Memon	Legal Officer	Shehri, Citizen for Better Environment (CBE)
18.	Mr. Ali Rasheed	Executive Member	Shehri, Citizen for Better Environment (CBE)
19.	Dr. M Mansha	Director Earth Sciences	SUPARCO
20.	Mr. Tayyab Shafique	Environmental & Social Expert	Global Environmental Management Services (GEMS) Pvt. Ltd.
21.	Ms. Kanwal Khatri	ESIA Technical Writer	Global Environmental Management Services (GEMS) Pvt. Ltd.
22.	Ms. Maria Kausar	ESIA Technical Writer	Global Environmental Management Services (GEMS) Pvt. Ltd.

S. No	Name	Designation	Organization
23.	Ms. Tahira Zafar	GIS Specialists	Global Environmental Management Services (GEMS) Pvt. Ltd.
24.	Engr. Musawir Munsif	Environmental Engineer	Global Environmental Management Services (GEMS) Pvt. Ltd.
<b>List of Participants of KIIs during March, April 2017</b>			
1.	Dr. Zafar Iqbal Shams	Professor	Institute of Environmental Studies, University of Karachi (IES, UoK)
2.	Dr. Hashim Zuberi	Head of Department, Professor	Department of Environmental Science, Sindh Madresat ul Islam University (SMIU)
3.	Mr. Shabbir Anwar Kazi	Director General Technical	Port Qasim Authority (PQA)
4.	Mr. Chen Shujian	Chief Commercial and Technical Depart	Port Qasim Electric Power Supply Company PQEPC

### 7.3 STAKEHOLDER CONSULTATION OUTCOMES

As discussed above stakeholder consultations were carried out with both primary and secondary stakeholders through scoping meeting and key informant interviews (KII), these are questionnaires and an effective tool for the process. The outcomes and findings of the consultation workshop have been presented below under separate headings, accordingly

(Refer to **Exhibit 7.2** for pictorial presentation of scoping meetings and **Exhibit 7.3** for KIIs)

#### 7.3.1 Outcomes, Concerns and Recommendations of Scoping Meeting Participants

Outcome of concerns and recommendations given by various stakeholders during the meeting are summarized as follows:

- The participants of the scoping meeting revealed optimistic views regarding the proposed project as 2 x 450 MW RLNG based power generation units will exhibit less environmental pressure in terms of air pollution and thermal plume dispersion as compared to the existing power generation units of BQPS-I operating on Heavy Furnace Oil (HFO).
- Majority of the participants suggested that the air dispersion and thermal plume modeling for the proposed project should be considered and made part of this ESIA study, not only this but it was



also suggested by the participants that the impacts on aquatic ecology should also be studied and in case adverse impacts are envisaged a proper mitigation plan should be devised and implemented throughout the life cycle of the proposed project.

- The participants also identified that Pakistan as a country is moving towards industrialization therefore at this stage environmental compliance should be treated as priority to reduce the chances of environmental deterioration in future.
- A unique suggestion was also proposed by the participants that, K-Electric may work with NEPRA or other regulatory bodies to gain approvals for producing water from power generation units which can significantly contribute in reducing the water crises of the country.
- Participants appreciated KE's effort for producing electricity while reducing the environmental pressure. However, they stressed upon K-Electric to ensure regular monitoring and compliance with the SEPA regulations.

**Exhibit 7.2: Pictorial Presentation of Scoping Meeting**

	
<p style="text-align: center;">Chief Executive (GEMS) Pvt. Ltd. while opening the scoping meeting</p>	<p style="text-align: center;">Manager Strategic Planning &amp; Business Development Department K-Electric while briefing proposed project features.</p>
	
<p style="text-align: center;">A view of Scoping Meeting Participants.</p>	<p style="text-align: center;">Representative from Shehri CBE While Raising Concern Regarding The Proposed Project</p>



Senior Advisor IUCN Pakistan while raising concerns about thermal pollution effects on aquatic life & plume modeling



Principle Scientific Officer NIO while raising concerns & suggesting K-Electric to produce water from power generation



General Manager – HSE G&T K-Electric while Observing Participants Concerns



Conservation Officer WWF raising concerns regarding the proposed project



Director Earth Sciences SUPARCO While Briefing The Participants Regarding The Thermal Plume & Air Dispersion Modeling



Deputy Director Technical SEPA Emphasizing The Environmental Monitoring & Compliance



### 7.3.2 Outcomes, Concerns and Recommendations of Stakeholder during KIIs

Outcomes of suggestions, concerns and recommendations made by different stakeholders during KIIs are summarized as follows:

(Refer **Exhibit 7.3** for pictorial presentation of KIIs)

#### 7.3.2.1 Director General Technical PQA

- The proposed project, seems to be relatively clean and it is expected that the proposed project will reduce the environmental burden within PQA vicinity by replacing old HFO based power generation units by adding 2 X 450 MW RLNG based power generation units.
- Since the proposed project is being developed within the already built up area of BQPS-I therefore the project developer does not need to acquire any approvals from PQA.
- The project developer must ensure compliance of all the relevant provincial, national and international applicable standards during the entire life cycle of the propose project.

#### 7.3.2.2 Chief of Commercial and Technical PQEPC

- PQEPC employees are already facing health complications in terms of upper respiratory disorders, as the HFO based power generation unit's pollution is dispersed within the existing boundaries of PQEPC. Therefore it is suggested that the project developer should replace all the power generation units by RLNG or natural gas power generation units, which will reduce the chances of health degradation of human resource within the close proximity of BQPS-I.

- LNG is relatively a clean fuel and since the project developer is replacing old HFO based power generation units by 2 X 450 MW RLNG based power generation units within the close vicinity of PQEPC, therefore it is expected that the level of air pollution may reduce significantly within the proposed project area surrounding.
- Moreover it also suggested that a detailed air dispersion and thermal plume modeling should be made part of this ESIA assignment and air pollution concentrations along with thermal plume dispersion should be properly documented, reported and project developer to ensure strict compliance with all the recommended mitigation measures suggested by the environmental consultants for the proposed development.
- Project developer must ensure environmental compliance during the entire life cycle of the propose project, and maintain good liaison with its neighboring industries.

#### 7.3.2.3 Assistant Professor, IES, UOK.

- The proposed project seems to be an environmental friendly initiative from the project developer since the power generation units based on natural gas and RLNG does not contribute in SO<sub>x</sub> and Particulate matter emissions during its operations, however still the project developer must ensure pollution abatement technologies installation for the proposed power generation units to reduce the probability of pollution.
- Usually one of the serious concern regarding the environmental pollution associated with power plant projects is air pollution and thermal plume dispersion within its close proximity, however RLNG based power generation units usually results in less air pollution mainly due to use of cleaner fuel and thermal plume dispersion due to reduced cooling water requirements.
- A detailed air dispersion and thermal plume modeling reports must be generated for the proposed project, and project developer must ensure strict compliance of SEQs during the entire life cycle of the proposed project, not only this but all the recommended mitigations measures suggested in ESIA study should be given due consideration and to be implemented in true spirit.
- Since Karachi is the industrial hub of country and number of industrial units along with human population is increasing on day to day basis therefore its electricity demand is also increasing which at present is not up to the mark, therefore the project developer should ensure continuous and smooth supply of electricity while reducing the electricity demand and supply gap.

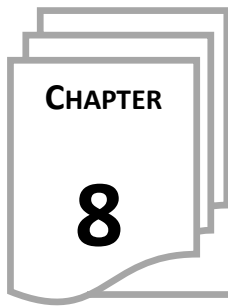
#### 7.3.2.4 Head of Department, Department of Environmental Sciences SMIU, Karachi.

- The current situation demonstrates that the current electricity demand of the city is not being catered properly, therefore the project developer must ensure continuous and smooth electricity throughout the city while reducing the demand and supply gap.

- Since the world is already moving towards sustainable development, therefore considering RLNG and Natural Gas as a fuel for the proposed power generation units is a sustainable step from the project developer.
- However it is strongly recommended that the project developer should execute the plantation plan within the project surrounding which will significantly reduce the level of air pollution, as mature trees serves as carbon sinks.

**Exhibit 7.3: Pictorial Presentation of KIIs**

	
KII at SMI University	KII at IES, UoK
	
KII at SEPCO	KII at PQA



# ANALYSIS OF ALTERNATIVES

## 8.1 GENERAL OUTLINE AND SCOPE

As discussed previously in this report, the proposed project mainly deals with construction and operations of 02 X 450 MW RLNG Based Combined Cycle Power Generation Units (CCPGU), which will include few modifications and installations of Gas Insulated Switchgears (GIS) at different locations.

Analysis of alternatives is an integral part of the ESIA process to select the best option among all the possible project options such as:

- Analysis of Project Refusal
- Analysis of Site Alternatives
- Analysis of Alternate technology/design

### KEY FEATURES OF PROJECT ALTERNATIVES

Analysis of alternatives is mainly based on following key aspects:

- ✓ Project Refusal
- ✓ Site Alternatives
- ✓ Technology Alternatives

The assessments and recommendations made by the ESIA team are presented below:

## 8.2 ANALYSIS OF PROJECT REFUSAL

### 8.2.1 Overview

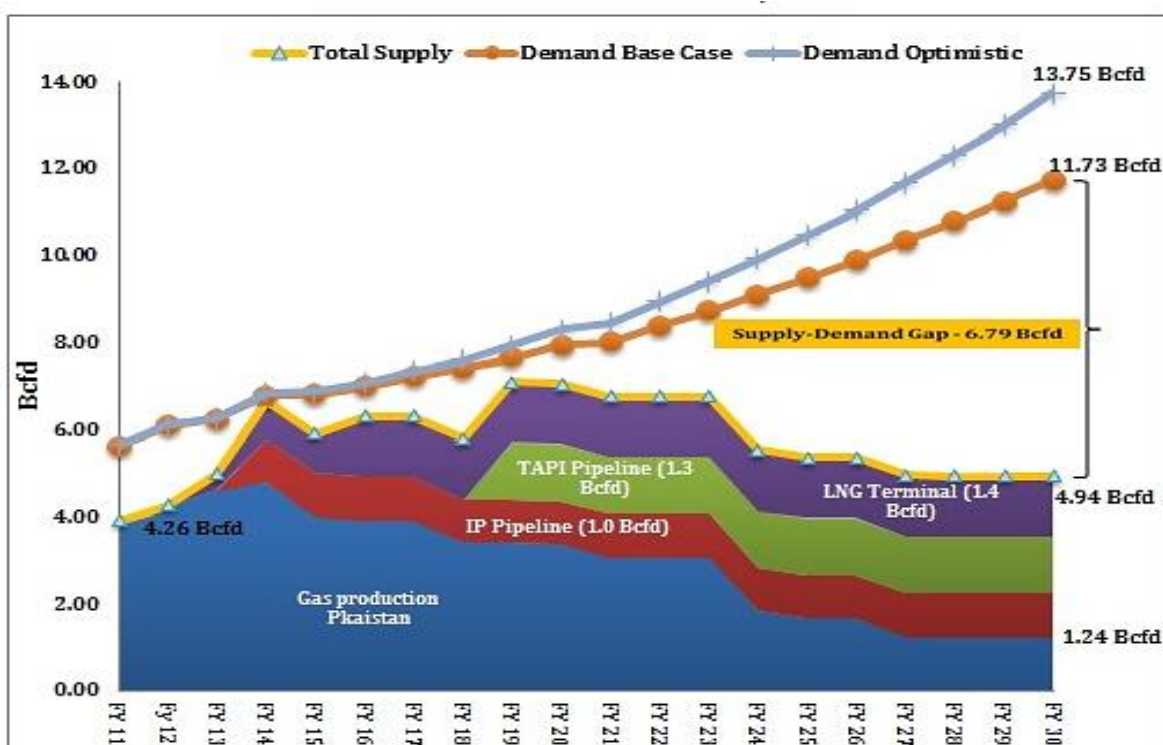
The “Project Refusal” means not proceeding with the proposed LNG based CCPGU and bringing no change to the baseline scenario and alternate technology option that is using HFO instead of Liquefied Natural Gas.

### 8.2.2 Key Observations

Pakistan is in the midst of a severe energy crisis that largely stemmed from mismanagement of natural resources in the country. Weak regulatory and pricing mechanisms in the natural gas sector have led to huge disparities between demand and supply. Pakistan has a large demand for natural gas and a well-established gas market and distribution system. At present, demand of natural gas is estimated

at around 8 Billion Cubic Feet (BCF) against a total supply of 4 BCF<sup>1</sup> As per Pakistan Gas Supply-Demand Study conducted in 2012 by ILF BeratendeIngenieure GmbH, over the next 17 years gas demand is projected to stand at 11.73 BCFD, while domestic supplies are expected to reach the level of 4.94 BCFD resulting in a huge shortfall of about 6.79 BCFD by FY 2030. The analysis was done considering the existing and planned capacity. Below given Exhibit shows the yearly natural gas supply-demand project. A base case scenario is considered based on existing scenario i.e. business as usual.

**Exhibit 8.1: Natural Gas Demand Projections**



Source: ILF Report on Gas/ Supply Demand Analysis and Base Gas Demand 2012

In order to meet the future energy challenges, to sustain and support economic growth, to mitigate the impact of widening shortfall, the Government has encouraged private investment LNG sector to establish an LNG Import projects under the LNG Policy 2002, 2006 & 2011.

Pakistan is going through an acute power shortage and the proposed project has the potential to increase electrical power production capacity, which is an urgent need of today’s energy deficient economy. Based on the above stated facts and figures KE being one of the prudent organization has also decided to place their reliance on imported LNG and initially replace their existing 2 x 210 MW NG and HFO based power generation units of BQPS-I by adding 2 X 450 MW RLNG based power generation units within the existing premises of BQPS-I.

The proposed project aims to improve Pakistan’s energy balance and decrease the gap between its growing energy requirements and available energy supplies in the country by utilizing environmental

<sup>1</sup> Total Gas Demand on System, 2013. Internal Documents of Ministry of Petroleum and Natural Resources. Islamabad, Pakistan

friendly RLNG fuel instead of more expensive, diesel and furnace oil, and the more environmentally detrimental coal, to generate electricity.

### **8.2.3 Rationale for Project Approval**

Based on the environmental expert's judgment and analysis which is supplemented by aforementioned facts and figures it can be interpreted that project refusal would mean loss 2 X 450 MW RLNG Electric Power Generating Units, thus ultimately resulting in bottleneck for smooth, continuous and uninterrupted electric supply to the city, while minimizing the industrial outputs and ultimately resulting in socioeconomic loss.

## **8.3 ANALYSIS OF SITE ALTERNATIVES**

### **8.3.1 Overview**

The basic purpose of "Analysis of Site Alternatives" is selecting the best possible site in terms of less environmental degradation while minimizing the environmental, social and monetary cost.

### **8.3.2 Key Observations**

As discussed previously in this ESIA document, the proposed 2 X 450 MW RLNG based power generation units will be installed within the already built up area of BQPS-I, as far as other project components are concerned such as grid installation and its modifications it will also be done within the already built up boundaries of KPC (Korangi Power Complex), Landhi Grid Station and Qayyumabad Grid Station.

The following criteria for installation of 2 X 450 MW RLNG based power generation units have been considered for the selection of the site for the proposed project:

- Availability of LNG import terminals.
- Ease of access to SSGC LNG tie in point.
- Availability of seawater for cooling;
- Availability of land;
- Low site preparation costs;
- Availability of access roads;

### **8.3.3 Rationale for Site Selection**

Based on the key observations as discussed above, the best possible site for installation of 2 X 450 MW RLNG based CCPGU at Port Qasim and Grid Modifications and Installations at KPC (Korangi Power Complex), Landhi and Qayyumabad will result in following key benefits:



- The sites selected for installation of proposed 2 x 450 MW RLNG based CCPGU and Grid Stations, is expected to exhibit insignificant impact and disturbance onto the existing land use patterns at Port Qasim, Korangi and Landhi since all the project components are proposed within the already built up area.
- The proposed power plant will be located at Port Qasim, nearby upcoming LNG Import Terminals and SSGC LNG tie in point, which will make RLNG transmission more viable and economical, and less environmental damaging.
- Sea water channels are present and the capacity is sufficient to fulfill the needs of the new proposed power generation units, therefore this site will not prove to be a new introduction to the sea system.

## **8.4 ANALYSIS OF ALTERNATE TECHNOLOGY/DESIGN**

### **8.4.1 Overview**

The basic purpose of “Analysis of Alternate technology/design” is selecting the best possible technology, design or arrangements to minimize the environmental degradation by promoting sustainable development.

### **8.4.2 Combined Cycle Technology**

#### **8.4.2.1 Key Observations**

Power Generation Plants are designed according to available fuels and feasibility of operation in existing environmental setups of the area. Coal, Petroleum, Gas and renewable energy sources are utilized for power generation around the world. In the proposed project, considerations were taken for available fuels (i.e. Liquefied Natural Gas and Natural Gas) and the durability of the proposed power plant.

The power plant is designed to generate electricity by utilizing the maximum available resources. Gas Turbines are selected to ensure continuous power generation from Liquefied Natural gas as well in case of shortage of Liquefied Natural Gas, Natural gas fuel is to be used. HRSGs are selected to recover heat and utilize the heat as energy source in Steam Turbine, this shall enhance power generation capacity as well as prove as effective resource utilization.

Not only this but project modifications and installations at Korangi, Landhi and Qayyumabad includes replacement of old AIS (Air Insulated Switchgear) by GIS (Gas Insulated Substation) which is relatively an advanced technology.

#### 8.4.2.2 Rationale for technology/design selection

At present among fossil fuels, the options currently available for power generation includes:

Heavy Furnace Oil (HFO)

Diesel

Coal and Natural Gas

All the available options exerts pressure onto the existing environment in terms of pollution not only this but power plants operating on aforementioned fuels also require a significant amount of financial resources to install sophisticated pollution abatement technologies to reduce the pollution levels.

However power RLNG, used in power generation emits about 50 per cent fewer greenhouse gases than coal and far fewer smog-causing air pollutants.<sup>2</sup>

Moreover the proposed GIS technology is used as a compatible grid station option and it needs less space and is cost-effective in terms of maintenance. The area available will suffice for the installation of GIS.

---

<sup>2</sup> <http://blog.transcanada.com/bcs-Ing-projects-will-reduce-global-ghg-emissions-and-air-pollution-experts-say/>



# ENVIRONMENTAL IMPACTS AND MITIGATIONS

---

## 9.1 GENERAL OUTLINE AND SCOPE

As discussed previously in chapter 2; project description of this ESIA document, the key project component is installation of 2 X 450 RLNG based power generation units within the existing boundaries of BQPS-I at PQA and including modifications at Korangi, Landhi as well as Qayyumabad as sub components of the proposed project, therefore the key focus during the impact assessment remained on the aforementioned component. Moreover after a thorough review and assessment of the existing environmental and socio-economic conditions and review of technical data, a team of environmental professionals analyzed the significant environmental impacts and suggested the necessary measures for mitigating the impacts. This chapter presents the environmental impact assessment of the proposed project as a whole including all the components.

This section discusses the potential environmental and social impacts of the proposed activities associated with construction and operational phase of the proposed project additionally this section of the report predicts the magnitude of the impact, assess its significance, recommends mitigation measures to minimize adverse impacts, and identifies the residual impacts of the proposed project.

The discussion starts with a description of the methodology used for the impact assessment. The impacts on the environment from various activities of the proposed project can be categorized as follows:

### Impact on Physical Resources

- Topography and Land use pattern

### Impact on Environmental Resources

- Air Quality
- Noise Levels
- Surface and Ground Water Quality
- Soil Quality

### Impact on Ecological Resources

- Terrestrial Ecology
- Aquatic Ecology

### **Impact on Human Environment**

- Health and Safety

### **Socio-economics**

- Road Safety & Traffic
- Livelihood & Economy

### **Waste Disposal**

- Liquid and Solid waste disposal

## **9.2 IMPACT ASSESSMENT METHODOLOGY**

Potential impacts from the proposed project activities were identified by thorough review of the project activities, study of surrounding environment, review of literature, review of previous similar studies and expert's judgment.

The identification and assessment of environmental impacts is based on the local and international guidelines as discussed previously in chapter 3; legislative requirements of this ESIA document which was supplemented by review of project activities, expert's judgement study of surrounding environment, review of literature and review of previous similar studies. The assessment procedure includes following steps:

### **a. Prediction of the potential environmental and social impacts**

This step refers to the description, quantitatively (where possible) or qualitatively impacts of the proposed project. This may be achieved through comparison with other similar activities.

### **b. Definition of the Criteria for Determining Significance**

The consequence of the proposed activity is evaluated by comparing it against a recognized Significance Criteria. The criteria are of the following types:

- Institutional recognition laws, standards, government policies, or plans;
- Technical recognition guidelines, scientific or technical knowledge, or judgment of recognized resource persons;
- Public recognition social or cultural values or opinion of a segment of the public, especially the community directly affected by the proposed project;
- Professional interpretation of the evaluator.

### **c. Identification of the mitigation measures**

If it is determined that the predicted impact is significant then the suitable mitigation measures are identified. There is a range of mitigation measures that can be applied to reduce impacts. Broadly, these measures can be classified into four categories:

- Avoiding the impact altogether by not taking certain proposed activity or parts of an activity, for example, using CFC-free equipment to avoid impact on ozone layer;
- Minimizing impacts by limiting the degree or magnitude of the activity, for example, minimizing dust emission by reducing vehicle speed;
- Rectifying the impact by repairing, rehabilitating, or restoring the affected environment;
- Compensating for the impact by replacing or providing substitute resources or environments.

The project developer plays a key role in implementing the mitigation plan and assessing the feasibility of proposed measures.

### **d. Evaluation of the residual impacts**

Incorporation of the suggested mitigation measures reduces the adverse impact of the proposed project and brings it within the acceptable limit. This step refers to the identification of the anticipated remaining impacts after mitigation measures have been applied.

### **e. Identification of the monitoring requirements**

The last step in the assessment process is the identification of the minimum monitoring requirements. The scope and frequency of the monitoring depends on the residual impacts, and its details are later addressed in Chapter 10; Environmental Management and Monitoring Plan (EMMP) of this ESIA document. The purpose of monitoring is to confirm that the impact is within the predicted limits and to provide timely information if unacceptable impact is taking place.

## **9.3 IMPACT ASSESSMENT (CONSTRUCTION PHASE)**

### **9.3.1 Impact on Physical Resources**

#### **9.3.1.1 Topography and Land use**

The activities associated with construction phase, may result in changes in topography however no major impacts onto the existing land use pattern is envisaged at all project locations.

#### **a. Potential Impact**

The activities expected to exhibit impacts onto the surface topography at all project locations may include excavation activities, site leveling and grading etc. Further, the grading and leveling of the site

are likely to result in modified surface topographical regime at proposed BQPS-III project site at Port Qasim, while small scale excavation and site leveling activities are envisaged at other project modification sites including Korangi, Landhi and Qayyumabad, these sites may also be impacted by loss of top soil and soil erosion though the impact on the topography at project modification sites is expected to be insignificant.

#### **b. Criteria for Determining the Significance**

An adverse impact will be interpreted if surface topography is modified and the proposed project site at PQA is flooded during rainy season, meanwhile an adverse impact onto the surface topography of project modification sites will be interpreted if the fact is established that the topographic elevation of project sites is modified and prominent heaps are observed.

#### **c. Mitigations**

- Proper site leveling should be ensured, in order to minimize the probability of topographic changes at and project site flooding during rainy season at all project locations.
- Ensure that construction material such as cement and or ready mix is handled properly and no residual material is left unattended so as to avoid the probability of formation of heaps and uneven structures

#### **d. Residual Impacts**

- If the suggested mitigation measures are implemented, disturbance to the surface topography will be minimized.

#### **e. Monitoring Requirements**

- Surface topography, to be monitored during construction by an Independent Environmental Monitoring Consultant.

### **9.3.2 Impact on Environmental Resources**

#### **9.3.2.1 Ambient Air Quality**

##### **a. Potential Impact**

It is anticipated that all project components i.e. 2 x 450 MW RLNG based CCPGU installation and grid installations or modifications may require small scale excavation, site leveling and demolition of old structures which may result in elevated levels of Dust and Particulate Matter dispersion at proposed project locations. Not only this but un-tuned construction equipment, vehicles and machineries may result in elevated levels of SO<sub>x</sub>, NO<sub>x</sub>, PM<sub>10</sub> and CO, thereby affecting the air quality of the proposed project surrounding which will be transitory in nature. Not only this but release of welding fumes and VOC from welding / metal fabrication works, surface cleaning and painting; is also anticipated, the

fumes generated during welding and metal cutting activities and hazardous air pollutants released during spray-painting can cause health hazard to workers.

#### **b. Criteria for Determining the Significance**

An adverse impact will be interpreted if the ambient air quality at all the proposed project locations exceeds the prescribed SEQs limits.

(Refer chapter 2 to observe project locations)

#### **c. Mitigations**

- Use of standard construction equipment and vehicles;
- Scheduled maintenance of equipment and vehicles including engine tuning, filter cleaning, etc.;
- Water spraying will be done to reduce dust emissions;
- Enclosed painting booths and dedicated fabrication areas in favor of wind direction so the fumes may divert away from the site;
- The vehicle speeds on graded roads will be limited in order to minimize dust emissions.

#### **d. Residual Impacts**

- Dust and Particulate matter dispersion will occur but will be transitory in nature. Fumes from painting and fabrication works will be controlled to minimized levels.

#### **e. Monitoring Requirements**

- Ambient air quality monitoring including critical pollutants such as SO<sub>x</sub>, NO<sub>x</sub>, PM<sub>10</sub> and CO to be conducted by engaging Independent Environmental Monitoring Consultant. The monitoring reports to be submitted quarterly to SEPA, providing compliance status with applicable regulations.

### **9.3.2.2 Noise**

#### **a. Potential Impact**

It is anticipated that the heavy equipment used for the construction work, fabrication activities, earthwork such as grading and excavation, and the vehicles used for transportation of men and materials to site may result in elevated levels of noise which may serve as nuisance to the workers working in close proximity of the construction sites, however it is important to note that the major construction activity is expected to be carried out during the daytime and all the proposed project sites at Port Qasim, Korangi and Landhi are far away from densely populated areas, only few residential plots were observed during the surveys although these plots are far away from the proposed project sites.

#### **b. Criteria for Determining the Significance**

An adverse impact will be interpreted if, the noise levels at within the close proximity of the proposed project construction sites exceeds the SEQS limits.

#### **c. Mitigation Measures**

- Noise levels as per SEQS will be maintained at the fence lines of the construction sites;
- Project construction zone to be barricaded and proper signs boards to be displayed at all construction sites.
- Unauthorized personnel will not be allowed to access construction zone;
- Onsite workers associated with construction activities will be provided with adequate 'personal protective equipment' (PPE) to reduce their probability of high noise exposure;
- Construction equipment/machineries will be provided with suitable noise dampening systems such as mufflers, silencers, etc. as feasible, to minimize noise at source;
- Also, the construction activities will be scheduled / planned in such a way as to prevent high noise activities during night times and simultaneous operation of multiple high noise equipment will be avoided to the extent feasible.

#### **d. Residual Impact**

- Strict implementation of the proposed mitigation measures is not likely to leave any long-term residual impact, however the minimal level of noise is still expected from proposed project activities.

#### **e. Monitoring Requirements**

- During construction phase periodic noise level monitoring will be carried out as prescribed in SEQS, by an IEMC. The ambient noise levels and noise emission from equipment and machineries will also be monitored.

### **9.3.2.3 Surface and Groundwater Quality**

#### **a. Potential Impact**

Since the proposed 2 X 450 MW RLNG based CCPGU will be installed within the existing premises of BQPS-I (Bin Qasim Power Station) and will replace existing unit 3 and 4, therefore there is no need to develop new discharge channels as the discharge channels for existing unit 3 and 4 will be used for newly proposed power generation units, therefore the impact associated with development of discharge channel is not foreseen for the proposed project. However construction residue and debris if not handled and stored properly may result in seawater contamination, while on the other hand it is important to note that the proposed power plant will be installed near the coastline at Port Qasim



and there is no significant groundwater resource within the vicinity of power plant installation therefore no impact on groundwater quality is envisaged.

As far as project modification sites at Korangi, Landhi and Qayyumabad is concerned there is no significant surface water source nearby these modification sites, and it is anticipated that the impact on groundwater quality is insignificant since the proposed project modification sites does not involve heavy duty construction works.

#### **b. Criteria for Determining the Significance**

A significant impact on the surface water quality will be interpreted if improper discharge of construction material onsite causes nuisance and may result in disturbed surface water visual aesthetics.

#### **Mitigation measures**

- Ensure that the all liquid raw material such as oil, lubricants and chemical at all proposed project sites are stored within the storage yard with impermeable floors and roof top, the storage yard should be protected with secondary containment facility with appropriate labeling, this will significantly reduce the chances of liquid waste or material discharge into the sea during the accidental spill or rain water runoff, not only this but the but such kind of storage will also reduce the chances of ground water contamination by impermeable flooring.

#### **c. Residual Impacts**

Residual impacts are foreseen to be negligible / low in this case if recommended mitigation measures are adhered with.

#### **d. Monitoring Requirements**

Visual inspection and chemical testing of surface water quality to be done by an Independent Environmental Monitoring Consultants. The parameters to be monitored includes:

- TSS
- pH
- Temperature
- Oil and grease

### **9.3.2.4 Soil Quality**

#### **a. Potential Impact**

Since the proposed project will be developed within the existing boundaries of already built up area of BQPS-I and modifications associated with the proposed project will also be made within the built up areas at Korangi, Landhi and Qayyumabad, hence small scale excavation will be required, which

may result in soil erosion, not only this but leakage and spillage of construction material and or leakages from construction machineries may also result in soil contamination.

#### **b. Criteria for Determining the Significance**

The adverse impact onto the site soil will be interpreted in case if it is contaminated by spillage of construction material.

#### **c. Mitigation Measures**

- Careful use of heavy machineries and equipment should be ensured in order to prevent leakages which may result in release of contaminants directly onto the soil.
- Ensure that malfunctioning machineries should be kept away from exposed soil area and should be repaired on immediate basis at designated workshops having impermeable floors.
- A spill prevention response team will be available throughout the construction phase.

#### **d. Residual Impacts**

Residual impacts are foreseen to be negligible / low in this case if recommended mitigation measures are adhered with.

#### **e. Monitoring Requirement**

Visual inspections will be carried out by an Independent Environmental Monitoring Consultant to ensure that the soil within the project surrounding is not being contaminated during the project activities.

### **9.3.3 Impact on Ecological Resources**

#### **9.3.3.1 Terrestrial Ecology**

##### **a. Potential Impact**

The impact on terrestrial ecology is envisaged to be insignificant as none of the Species within or around the project sites that are classified as rare, threatened, endangered or of significant conservation value. However small scale impact onto the terrestrial ecology is envisaged largely due to site clearing and leveling activities. Further, disturbance to ecology in the area will also result from increase in noise during construction activities and vehicle movements, which can be easily mitigated by adopting best and safe industrial practices.

Avifauna in the area are very common and are highly adaptable or can easily re-colonized vacant habitats whenever necessary. In general, the BQPS-III project is foreseen to have a very minimal or insignificant impact to the flora and fauna in the area. The development will cause a very minimal

mortality to plant life and to some extent loss of foraging area for avifauna. In addition, the fauna, which is largely composed of birds, at the site are mostly omnivores (generalist feeders) that can easily shift from one diet to another. This ecological trait will permit them to move from other vegetated areas especially the tree communities surrounding project site.

### **9.3.3.2 Aquatic Ecology**

#### **a. Potential Impact**

The impact on aquatic ecology is envisaged to be insignificant as the proposed project does not require construction of new discharge channels, the aquatic species have already adapted to the existing baseline conditions of the proposed project area and no additional burden or pressure will be added to these species. However the possible release or leakage of any construction material containing toxic waste may result in short term adverse impact on to the aquatic ecology which can be mitigated by implementation of standard construction practices and implementation of spill prevention and containment plan.

### **9.3.4 Impact on Human Environment**

#### **9.3.4.1 Health and Safety**

##### **a. Potential Impact**

Construction phase activities may result in severe health and safety hazards and health conditions. It is important to note that the untrained workers may cause harm to themselves as well as others due to lack of awareness and skills.

##### **b. Criteria for Determining the Significance**

A significant impact will be interpreted if a large number of frequent accidents, incidents, injuries and hazards occurs at proposed project sites.

##### **c. Mitigation Measures**

The contractor will ensure that activities at the site will not cause damage to lives and properties by implementing the following measures to ensure the health and safety of workers and the public.

- Only skilled workers will be allowed to work at the construction sites;
- Provision of first aid facilities for workers at site for meeting the emergency needs of workers;
- Emergency response training should be given to employees and evacuation drills should be scheduled and conducted
- Ensure that hazards associated with manual lifting are controlled by proper lifting techniques, work rotation system will reduce the chances of being exposed to work related stress associated with construction activities.

- Unauthorized personnel will not be allowed to access the proposed project site without permission and safety permits.
- Arrangement of proper first aid unit and emergency vehicle to take affected personnel to the nearest medical facility.
- Workers should be facilitated by providing appropriate work specific PPE's;
- Construction area will be fenced to avoid accidents and will be properly drained to avoid ponding of water that could harbor mosquitoes and other disease vectors;
- Accidents records will be maintained;
- Use of signage must be implemented.
- The project developer must ensure implementation of proper HSEQ policy at all project locations so as to reduce the chances of occurrence of frequent hazards

(Refer **Annexure-IV** for KE HSEQ Policy)

#### **d. Residual Impacts**

Residual impacts are foreseen to be negligible / low in this case if recommended mitigation measures are implemented

#### **e. Monitoring Requirements**

Risk assessment to be carried out on weekly basis by engaging Independent Environmental Monitoring Consultants

### **9.3.5 Socio-Economics**

#### **9.3.5.1 Road Safety and Traffic Management**

##### **a. Potential Impact**

Since the proposed project developments, installations and modifications will be undertaken within the existing boundaries of already built up area of BQPS-I, KPC, Landhi and Qayyumabad therefore the construction equipment and material carrying vehicles will be parked in designated areas within the premises of aforementioned project sites therefore the impact on road safety and traffic management is anticipated to be insignificant. However it is strongly recommended that the drivers of construction equipment and material carrying vehicles should have valid licenses and must obey all the relevant road safety standards, protocols and traffic rules. A proper traffic management plan for incoming and outgoing project specific vehicles is attached as **Annexure V**.

### **9.3.5.2 Impact on Livelihood & Economy**

#### **a. Potential Impact**

Since the proposed project will use the existing facilities such as intake and outfall, hence no further conflict or loss of sea access for the local fishermen due to this project is envisaged, and accordingly the impact on livelihood is assessed to have negligible/ minor significance. However, construction activities will require significant number of local skilled and unskilled workers therefore a positive impact on the local livelihood during the construction phase through creating new job opportunity is envisaged. In addition, local hotels (Dhabas) in project vicinity will also be benefited in terms of increased routine sales. Considering the above, beneficial impacts are envisaged from the proposed project on the local employment and economy. Therefore, it can be concluded that the proposed project will set positive impact on local livelihood option.

### **9.3.6 Waste Disposal**

#### **9.3.6.1 Solid waste:**

##### **a. Potential Impact**

The construction phase of the proposed project is expected to generate wastes including; packing waste; scrap, excess construction materials and debris, empty containers and drums, used lubricating oils and chemicals etc. Besides being an eyesore, the waste can also pose a health hazard; pollute soil, surface and ground water if disposed of improperly. Majority of the construction material to be used and waste generated as a result of construction activity will be inherently less reactive and chemically inert under normal conditions however, its handling and storage may pose adverse impacts of minor nature which could easily be controlled by employing the recommended mitigation measures in this report.

##### **b. Criteria for Determining The Significance**

A significant impact will be interpreted the construction waste is scattered and dispersed at project sites and its surroundings.

##### **c. Mitigations Measures**

A waste management plan will be developed by the contractor after approval of K-Electric before the start of the construction activities. Key elements of the waste management system will be the following:

- Separate bins will be placed for different type of wastes - plastic, paper, metal, glass, wood, and cotton;
- Recyclable material will be separated at source. The recyclable waste will be sold to waste contractors for recycling;

- No waste will be dumped at any location outside the proposed site boundary;
- All hazardous waste will be separated from other wastes. Hazardous wastes will be stored in designated areas with restricted access and proper marking. Hazardous wastes will be disposed of through approved waste contractors;
- Surplus construction materials including partially filled chemical and paint containers will be returned to suppliers. Inert construction wastes will be sold as scrap to contractors;
- Record all waste generated during the construction period will be maintained. Quantities of waste disposed, recycled, or reused will be logged on a Waste Tracking Register;
- Training will be provided to personnel for identification, segregation, and management of waste.

#### **d. Residual Impacts**

Proper implementation of the mitigation measures will ensure that the residual impact from waste is minimal.

#### **e. Monitoring Requirements**

An IEMC will carry out monthly visual inspections to ensure good solid waste management practices at proposed project site.

## **9.4 IMPACT ASSESSMENT (OPERATIONAL PHASE)**

### **9.4.1 Impact on Physical Resources**

#### **9.4.1.1 Topography and Land use**

Since all the developments and installations will be executed during the construction phase, hence no impact on to the topography and land use pattern is envisaged during the operational phase of the proposed project.

### **9.4.2 Impact on Environmental Resources**

#### **9.4.2.1 Air Quality**

##### **a. Potential impact**

Quantitative techniques are used to assess the impacts of air emissions during the operation phase, for which computer simulation models are used. AERMOD software was used for conducting air dispersion modeling, which demonstrated air dispersion comparison scenario for existing HFO based unit 3 & 4 and proposed 2 X 450 MW RLNG based CCPGU.

This modeling addressed emissions from stationary point sources. The emissions from existing HFO based power generation unit 3 & 4, were calculated separately and were found to be significantly high as compared to the emissions from newly proposed 2 X 450 MW RLNG based CCPGU which were also calculated separately and were found to be insignificant, therefore the air dispersion modeling concluded that the air pollution concentrations will reduce significantly not only this but the intensity of the impact on air quality due to emissions from the proposed project is expected to decrease with increasing distance from the project-site

Detailed findings of Air Dispersion modeling is attached as **Annexure VI**. It is to be noted that maximum air dispersion will occur when the proposed power plant will run on complete load. However, on mean calculations of pollutant emissions, they were all found to be within SEQS.

#### **b. Criteria for Determining the Significance**

An adverse impact will be interpreted if the newly proposed 2 X 450 MW RLNG based CCPGU exceeds the maximum permissible SEQS limits.

#### **c. Mitigation Measures**

- Ensure Fuel to Air Ratios are maintained;
- Ensure power plant maintenance;
- Ensure Fuel quality is excellent for utilization even after fuel treatment.

#### **d. Residual Impacts**

Strict implementation of the proposed mitigation measures is unlikely to leave any long-term residual impact.

#### **e. Monitoring Requirements**

Periodic air quality monitoring will be carried out as prescribed in SEQS, by an IEMC. The parameters to be monitored includes:

- NOx
- CO

### **9.4.2.2 Noise**

#### **a. Potential Impact**

The proposed project will include a number of noise sources, which will have potential adverse impacts on the workplace and ambient noise levels. Most of the sources are continuous which include the engines / generators, steam turbines and pumps.

The continuous exposure to the elevated levels of noise may result in; headaches, hearing problems and even loss in severe conditions, anxiety, and accumulation of stress hormones and hypertension.

All these health conditions may affect the overall health of the exposed workers and laborers associated with the proposed project.

#### **b. Criteria for Determining the Significance**

An adverse impact will be interpreted if the noise level exceeds the prescribed SEQs limits.

#### **c. Mitigations Measures**

- Proper maintenance of all the equipments to be utilized during operational phase will be maintained throughout the entire life cycle of the proposed project to reduce the chances of elevated noise levels.
- High noise areas, will be identified and proper safety signs indicating noise hazards will be displayed, KE Employees accessing high noise area will always wear PPE's like ear protection muffs or ear plugs;
- Unauthorized personnel will not be allowed to access high noise areas.

#### **b. Residual Impacts**

- Nuisance or health effects caused by high noise will be reduced

#### **c. Monitoring Requirements**

- During operational phase periodic noise level monitoring will be carried out as prescribed in SEQs, by an IEMC. The ambient noise levels and noise emission from equipment and machineries will also be monitored.

### **9.4.3 Impact on Ecological Resources**

#### **9.4.3.1 Terrestrial Ecology**

##### **a. Potential Impact**

It is important to note that the proposed project area is already under PQA industrial zone therefore, the terrestrial species observed have already adapted to such environment. Although some of them may still be under the phase of adaptation and their migratory paths and or habitats may be affected due to maintenance activities resulting in noise and vibration however the anticipated impact will be transitory and insignificant in nature.



### 9.4.3.2 Aquatic environment.

#### a. Potential Impact

As mentioned earlier, the proposed power plant is the replacement of existing HFO based power generation unit 3 & 4 at BQPS-1 in Port Qasim and proposed 2 X 450 MW RLNG based CCPGU is designed with efficient technologies which would utilize less amount of water than existing two units. Moreover it is important to note that a detailed thermal plume modeling has been conducted for the proposed project and it has been predicted that during its operations and by abandoning existing HFO based unit 3 & 4 of BQPS-I there would be reduced discharge flow rate and velocity therefore, it is expected that impact on the marine ecology with Regulatory Mixing Zone of 100 m due to this project would be minimized and would result in lesser area to be affected due to reduced discharge from 144,780 m<sup>3</sup>/hr to 69,622 m<sup>3</sup>/hr and flow velocity which would also result in plume dispersion with shorter distance in downstream i.e. 8.86 m.

Moreover it is important to note that the potential impact from the discharge of effluents is tempered by the following factors: the total volume of brine being released; the constituents of the discharge; and the amount of dilution prior to release. Further, it may be noted that the treated effluents will be combined with return cooling water prior to discharge, which will result in significant dilution of the effluents and in turn will reduce the concentration of various constituents. Furthermore, the combined effluents from the plant will be discharged to sea through existing common marine outfall, which will result in further dilution prior to discharging to the marine environment.

#### b. Criteria for determining the significance

Temperature difference in water will be caused due to heat exchange in plant. To assess the impact Thermal Plume modeling is conducted. CORMIX is used for assessing thermal plume variance. The mixing zone will completely neutralize the temperature difference. The Thermal Plume modeling is attached as **Annexure-VII**. However the significant impact will be interpreted if temperature of the effluent discharge exceeds 3 °C of ambient seawater temperature at the edge of a scientifically established mixing zone.

#### c. Mitigations Measures

- Retain effluent prior to final discharge for treatment unless the quality remains within SEQS;
- The treated water can be reutilized for green belt areas.

#### Residual Impacts

- Residual impacts are foreseen to be negligible / low in this case if recommended mitigation measures are strictly implemented

#### Monitoring Requirements

- Quarterly benthic faunal sampling at the proposed project site will be carried out by an Independent Environmental Monitoring Consultant to check the biodiversity status of the project area.

## **9.4.4 Impact on Human Environment**

### **9.4.4.1 Health and safety**

#### **a. Potential Impact**

Operational activities which may result in health and safety hazards such as, slipping, tripping, falling from height, electrocution, fires, explosions and suffocation in confined space etc. One of the major potential issue related to the health and safety of the workers working in close proximity of the proposed project area includes accidental LNG release, fire hazards and other health and safety hazards.

#### **b. Criteria for determining the significance**

A significant impact will be interpreted if a large number of fire, explosions, frequent accidents, incidents, injuries and hazards occurs at proposed project sites.

#### **c. Mitigation Measures**

- Ensure that all the safety and security procedures are in place and implemented in true spirit.
- Ensure proper maintenance of firefighting systems during the entire life cycle of the proposed project.
- All the workers involved in, operational activities will be provided with proper PPEs according to their job description including; safety belts, footwear, helmets, goggles, eye-shields, and coveralls to workers depending on their nature of work.
- Necessary training regarding safety aspects to the personnel working at the proposed project site will be given.
- Material Safety Data Sheet (MSDS) for chemicals, if any, will accompany the consignment.
- The project developer must ensure implementation of proper HSE policy at all project locations so as to reduce the chances of occurrence of frequent hazards.

#### **d. Residual Impacts**

- Residual impacts are foreseen to be negligible / low in this case if recommended mitigation measures are adhered with.

#### **e. Monitoring Requirements**

- HSE Inspections and detailed risk assessments will be carried out on monthly basis by engaging IEMC at proposed project site to evaluate the health and safety practices at the project site.

## **9.4.5 Socio-Economics**

### **9.4.5.1 Road Safety & Traffic**

#### **a. Potential Impact**

Since the proposed project will operate in an already built up area of BQPS-I within industrial zone of PQA, therefore vehicular movement for employs mobilization is already a routine activity within the given area and a sufficient road infrastructure is also available. However probability of road accidents and traffic congestions always remains therefore all the workers moving from different parts of the city towards project site will have valid driving licenses and will obey traffic rules at all times.

### **9.4.5.2 Livelihood & Economy**

#### **a. Potential Impacts**

Since the proposed project will use the existing facilities such as intake and outfall, hence no further conflict or loss of sea access for the local fishermen due to this project is envisaged, and accordingly the impact on livelihood is assessed to have negligible/ minor significance. However, project operations will require significant number of skilled and unskilled workers therefore a positive impact on the local livelihood during the project operations is expected by creating new job opportunity. In addition, local hotels (Dhabas) in project vicinity will also be benefited in terms of increased routine sales. Not only this but adding 2 X 450 MW RLNG based CCPGU will result in smooth and continuous supply of electricity which is expected to result in continuous and smooth industrial production thus contributing towards economic development.

## **9.4.6 Waste Disposal**

### **9.4.6.1 Water and Waste water**

#### **a. Potential Impacts**

Water requirement during operation phase of the proposed project will be sourced from existing channel of sea. Domestic and process wastewater will be generated during operational phase. The wastewater can be a potential source of pollution to surface and sea water.

#### **b. Criteria for Determining the Significance**

A significant impact will be interpreted if the discharge effluent water does not meet the prescribed SEQS limits or exceeds the limits.

#### **c. Mitigations Measures**

- Appropriate facilities to be provided for collection, storage and routing the wastewater streams to treatment plant and facilities are to be provided;

- Appropriate sludge handling and disposal facilities are to be provided for waste treatment sludge.
- Effluent sewers to be periodically cleaned and inspected for integrity in order to ensure effective transport of effluents and prevent overflows and leakages and infiltration;
- Sanitary wastewater from all sections of the facility to be collected and routed to sanitary treatment system
- All run off from the process area to be routed for treatment prior to disposal.

#### **d. Residual Impacts**

- Residual impacts are foreseen to be low in this case if recommended mitigation measures are adhered with.

#### **e. Monitoring Requirements**

- Treated water from the WTP is to be periodically analyzed for relevant parameters in order to assess compliance with SEQS. Analysis reports will be submitted to SEPA as required; and
- Periodic audits to be conducted to assess implementation of the control measures and results of audits to be reviewed and corrective actions to be taken for any deviations.

### **9.4.6.2 Waste Generation and Disposal System**

#### **a. Potential Impacts**

During scheduled and unscheduled maintenance work on the engines and auxiliary systems there can be considerable amounts of spare part and packaging waste. The large majority of the rejected engine spare part waste is metal and can be sold for recycling. Also maintenance on auxiliary systems gives rise to rejected spare part waste, which could consist of metal, electronic components, hazardous components (mainly batteries and filters) and other materials like rubber, plastic, glass fibre, graphite, porcelain, etc.

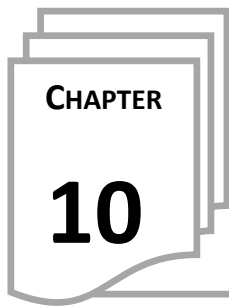
It should be kept in mind that the stated values are long term average ranges, within which typical values might fall. The true values are dependent on site conditions, quality of fuel and other fluids, habits of workers, maintenance work done, etc. The amount of hazardous waste is largely dependent on how hazardous products (e.g. lube oil and solvents) are delivered.

The estimated waste generation during operation phase is provided in **Exhibit 9.1**.

**Exhibit 9.1:** Anticipated Waste Generation during Operation

Waste Type	Estimated Daily Generation	Source	Onsite Waste Handling and Treatment	Disposal Method	Indicative Composition (of pollutants)
<b>Sludge</b>					
Sludge from oily water treatment	~4.6 m <sup>3</sup> /day	Oily water treatment unit	To be collected and stored in tank.	To be handed over to third party, which is licensed by relevant government agency to treat hazardous waste.	Contains oil and small amounts of e.g. metals. The concentrations are dependent on fuel quality and operation of systems.
Sludge from biological treatment	~0.05 m <sup>3</sup> /day	Biological water treatment unit	To be collected and stored in tank.	To be handed over to third party, which is licensed by relevant government agency to treat hazardous waste.	Dry content matter 3.8 – 8.2%
<b>Waste in solid form</b>					
Non-hazardous	40-300 kg/day	Offices, control rooms, social facilities, sanitary facilities, spare part packaging material, etc.	To be collected and stored at assigned area.	Part of the waste might be reusable, the rest should be sent for recycling or incineration/disposal by qualified waste vendor.	Domestic, paper, glass, landfilling waste, metal scrap (excl. spare parts), packaging material (wood, cardboard, plastic, polystyrene).

Waste Type	Estimated Daily Generation	Source	Onsite Waste Handling and Treatment	Disposal Method	Indicative Composition (of pollutants)
Hazardous	20-100 kg/day	Engine operation and offices	Should be handled, stored at assigned area and handed over, in accordance with IFCs EHS general guidelines section 1.6 Waste Management.	To be handed over to third party which is licensed by relevant government agency to treat hazardous waste.	Rags contaminated with hazardous products, contaminated cans and drums, used filters, lighting equipment, batteries, etc.
Filters (charge air and process ventilation)	6-15 kg/day	Charge air system (hazardous only if contaminated with oil) and process ventilation.	To be collected and stored at assigned area.	Sent for treatment by qualified waste vendor.	Depends on filter type.



# ENVIRONMENTAL MANAGEMENT AND MONITORING PLAN

---

## 10.1 OVERVIEW AND SCOPE

The potential environmental impact during the construction and operations of the proposed combined cycle LNG based units on various environmental components such as social, biological and physical environment were predicted in the course of the ESIA. The ESIA has also identified mitigation measures to minimize the environmental impact of the proposed project, keeping these effects within acceptable limits.

The EMMP (Environmental Management and Monitoring Plan) has been designed to address how the proposed measures will be implemented. It defines the responsibilities of the project developer and contractor; develops a system of checks and balances; proposes actions that are to be taken by each role player; and lays down the required documentation, communication, and monitoring procedures.

## 10.2 PURPOSE AND OBJECTIVES

The purpose of this EMMP is not only to address the expected environmental impacts of the proposed project, but also to enhance project benefits and to introduce standards of good practice to be adopted for the proposed project.

The primary objectives of the EMMP are to:

- Facilitate the implementation of the mitigation measures that are identified in the ESIA;
- Define the responsibilities of the project proponent and contractor and to provide a means for effective communication of environmental issues between them;
- Identify monitoring parameters in order to ensure the effectiveness of the mitigation measures.
- An integrated Environment Management System play important role in sustainable industrial development if their Environment Management and Monitoring Plan is more effective and economically beneficial covering all activities of the industry and give proper implementable guidelines.

The specific EMMP for the proposed activities of the PGPL LNG Import Terminal-2 has been prepared by assessment of impact scale which has been categorized as high, medium and low obtained by multiplying impact severity into likelihood. The impact scaling criteria has been presented below in **Exhibit 10.1**, a detailed EMMP in **Exhibit 10.2**.

**Exhibit 10.1:** Impact Scaling Criteria

IMPACT SCALING CRITERIA			
Severity	Rating	Likelihood	Rating
HIGH	3	HIGH	3
MEDIUM	2	MEDIUM	2
LOW	1	LOW	1
IMPACT SCALE = SEVERITY X LIKELIHOOD			
HIGH = 7-9			
MEDIUM = 4-6			
LOW = 1-3			

### SEVERITY

Impact severity has been categorized as follows:

**HIGH:** The anticipated environmental impact may adversely affect the environmental conditions.

**MEDIUM** The anticipated environmental impact may exhibit moderate effect onto the environmental conditions.

**LOW** The anticipated environmental impact is insignificant and may not affect the environmental conditions.

### LIKELIHOOD

**HIGH:** The anticipated environmental impact is most likely to occur.

**MEDIUM** The anticipated environmental impact is likely to occur.

**LOW** The anticipated environmental anticipated environmental impact is less likely to occur.



**Exhibit 10.2:** Environmental Management and Monitoring Plan

Aspect	Impact	Impact Scale <small>Severity X Likelihood</small>	Mitigation Safeguards	Residual Impact	Monitoring Parameter	Monitoring Location	Monitoring Frequency	Monitoring Responsibility
<b>Construction Phase</b>								
<b>Topography &amp; Landscape</b>	Formation of heaps due to improper handling of construction residue	1 X 2 = 2 <b>LOW</b>	<ul style="list-style-type: none"> <li>- Proper site leveling should be ensured, in order to minimize the probability of topographic changes at and project site flooding during rainy season</li> <li>- Ensure that construction material such as cement and or ready mix is handled properly and no residual material is left unattended so as to avoid the probability of formation of heaps and uneven structures</li> </ul>	1 X 1 = 1 <b>LOW</b>	Surface topography	Project sites at Port Qasim and Korangi Power Complex	Monthly	KE by engaging IEMC
<b>Ambient Air Quality</b>	Construction activities may result in following impacts:	2 X 2 = 4 <b>MEDIUM</b>	<ul style="list-style-type: none"> <li>- Use of standard construction equipment and vehicles;</li> <li>- Scheduled maintenance of back-up generators, equipment and vehicles including engine tuning, filter cleaning, etc.;</li> </ul>	2 X 1 = 2 <b>LOW</b>	Emissions of CO, NOX, PM10, and SOx from sources such as construction machineries and vehicle movement	All Project Installation and Modification Sites	Monthly	KE by engaging IEMC

Aspect	Impact	Impact Scale <small>Severity X Likelihood</small>	Mitigation Safeguards	Residual Impact	Monitoring Parameter	Monitoring Location	Monitoring Frequency	Monitoring Responsibility
	<p>Impairment of ambient air quality</p> <p>Chronic health issues</p> <p>Upper respiratory disorders</p>		<ul style="list-style-type: none"> <li>- Water spraying will be done to reduce dust emissions;</li> <li>- Enclosed painting booths and dedicated fabrication areas in favor of wind direction so the fumes may divert away from the site;</li> <li>- The vehicle speeds on graded roads will be limited in order to minimize dust emissions</li> </ul>					
<b>Noise</b>	<p>Headaches</p> <p>Hearing problems</p> <p>Accumulation of stress hormones</p> <p>Hypertension</p>	<p>2 X 2 = 4</p> <p><b>MEDIUM</b></p>	<ul style="list-style-type: none"> <li>- On site workers will be provided with adequate 'personal protective equipment' (PPE);</li> <li>- Construction equipment/machineries will be provided with suitable silencers;</li> <li>- Regular maintenance of construction machinery and equipment will be ensured</li> </ul>	<p>2 X 1 = 2</p> <p><b>LOW</b></p>	Noise levels and Construction Equipment/Machinery Maintenance Report	All Project Installation and Modification Sites	Monthly	KE by engaging IEMC

Aspect	Impact	Impact Scale <small>Severity X Likelihood</small>	Mitigation Safeguards	Residual Impact	Monitoring Parameter	Monitoring Location	Monitoring Frequency	Monitoring Responsibility
			<ul style="list-style-type: none"> <li>- Construction activities will be scheduled / planned in such a way as to prevent high noise activities during night times and simultaneous operation of multiple high noise equipment will be avoided to the extent feasible</li> </ul>					
<b>Surface and Ground Water Quality</b>	Seawater contamination by oil spillage from construction vehicles and equipment	2 X 2 = 4 <b>MEDIUM</b>	<ul style="list-style-type: none"> <li>- All liquid raw material such as oil, lubricants and chemical at all project sites will be stored within the storage yard with impermeable floors and roof top.</li> <li>- The storage yard should be protected with secondary containment facility with appropriate labeling, to significantly reduce the chances of liquid waste or material discharge into the sea during the accidental spill or rain water runoff.</li> </ul>	1 X 1 = 1 <b>LOW</b>	pH, TSS, Temperature Oil and Grease and visual inspection of Surface Water Quality	Proposed project Site at Port Qasim	Monthly	KE by engaging IEMC

Aspect	Impact	Impact Scale <small>Severity X Likelihood</small>	Mitigation Safeguards	Residual Impact	Monitoring Parameter	Monitoring Location	Monitoring Frequency	Monitoring Responsibility
<b>Terrestrial Ecology</b>	Minimal mortality to plant life  Loss of foraging area for avifauna	2 X 1 = 2  <b>LOW</b>	<ul style="list-style-type: none"> <li>- Green areas will be developed in vacant portions of proposed project areas;</li> <li>- Best and safe industrial practices should be adopted for the less disturbance of ecology of the area.</li> </ul>	1 X 1 = 1  <b>LOW</b>	Visual Inspection	Korangi Power Complex	Monthly Basis	KE by engaging IEMC
<b>Soil Quality</b>	Small scale excavations and site leveling may result in following impacts:  Soil erosion  Contamination of soil.	2 X 2 = 4  <b>MEDIUM</b>	<ul style="list-style-type: none"> <li>- Careful use of heavy machineries and equipment should be ensured in order to prevent leakages onto the soil.</li> <li>- A spill prevention response team will be available throughout all the activities for immediate action on site</li> </ul>	2 X 1 = 2  <b>LOW</b>	Visual Inspection	Proposed project sites at Port Qasim and Korangi Power Complex	Monthly Basis	KE by engaging IEMC
<b>Aquatic Ecology</b>	Small scale impact on aquatic ecosystem	2 X 2 = 4  <b>MEDIUM</b>	<ul style="list-style-type: none"> <li>- Existing drainage has bearing capacity of more effluent and will sustain rise in effluent</li> </ul>	2 X 1 = 2  <b>LOW</b>	Fish population density and productivity by fauna sampling and its laboratory analysis.	Proposed project Site at Port Qasim	Monthly	KE by engaging IEMC

Aspect	Impact	Impact Scale <small>Severity X Likelihood</small>	Mitigation Safeguards	Residual Impact	Monitoring Parameter	Monitoring Location	Monitoring Frequency	Monitoring Responsibility
			<p>discharge caused during construction activities;</p> <ul style="list-style-type: none"> <li>- Construction activities will be performed with complete standard procedures and minimal discharge will be produced</li> </ul>					
<b>Health &amp; Safety</b>	<p>Lack of awareness among general laborers about safety may lead to accidents</p> <p>Unskilled and untrained workers might cause harm to themselves and others</p> <p>Construction works may</p>	<p>3 X 2 = 6</p> <p><b>MEDIUM</b></p>	<ul style="list-style-type: none"> <li>- Ensure that hazards associated with manual lifting are controlled by proper lifting techniques, work rotation system will reduce the chances of being exposed to work related stress associated with construction activities.</li> <li>- Trained personnel will be appointed for the specific work</li> <li>- Unauthorized personnel will not be allowed to access the project site without permission and safety permits.</li> <li>- Arrangement of proper first aid unit and emergency vehicle to</li> </ul>	<p>2 X 1 = 2</p> <p><b>LOW</b></p>	<p>HSE inspections</p> <p>Risk assessment reports</p> <p>Record of Safety Talks</p> <p>Record of safety Incidents (Major &amp; Minor)</p> <p>Record of PPEs</p> <p>Visual Assessments</p>	All Project Installation and Modification Sites	Monthly	KE by engaging IEMC

Aspect	Impact	Impact Scale <small>Severity X Likelihood</small>	Mitigation Safeguards	Residual Impact	Monitoring Parameter	Monitoring Location	Monitoring Frequency	Monitoring Responsibility
	include many risks and hazards that may lead to severe injuries		take affected personnel to the nearest medical facility. - Workers should be facilitated by providing appropriate work specific PPE's; - Accidents records will be maintained					
<b>Road Safety and Traffic Management</b>	Traffic Congestion  Risk of accident	2 X 1 = 2  <b>LOW</b>	- Trained drivers and operators to drive the construction vehicles - Obey traffic and safety rules/precautions and traffic management plan.	1 X 1 = 1  <b>LOW</b>	Driver's license and traffic rules	NIL	NIL	NIL

Aspect	Impact	Impact Scale <small>Severity X Likelihood</small>	Mitigation Safeguards	Residual Impact	Monitoring Parameter	Monitoring Location	Monitoring Frequency	Monitoring Responsibility
<b>Livelihood &amp; Economy</b>	The proposed project will have positive impacts on local economy, however small scale conflicts between local vendors and project developer may occur	2 X 1 = 2 <b>LOW</b>	<ul style="list-style-type: none"> <li>- Specify time scale for construction activities</li> <li>- People from neighboring areas will be considered for unskilled employment</li> <li>- Suppliers and Vendors of neighboring areas will be given priority</li> <li>- Employment opportunities will be increased and the preference will be given to locals.</li> </ul>	1 X 1 = 1 <b>LOW</b>	Complaint register and Grievance Redress Mechanism (GRM)	All Project Installation and Modification Sites	Monthly	KE by engaging IEMC
<b>Solid waste</b>	Health hazards  Unaesthetic conditions	3 X 2 = 6 <b>MEDIUM</b>	<ul style="list-style-type: none"> <li>- Separate bins will be placed for different type of wastes - plastic, paper, metal, glass, wood, and cotton;</li> <li>- The material to be used during construction phase should be limited and should not exceed the needed amount so as to prevent solid waste production at project site.</li> </ul>	1 X 1 = 1 <b>LOW</b>	Visual inspections  Assessment of solid waste quantity and type	All Project Installation and Modification Sites	Monthly	KE by engaging IEMC

Aspect	Impact	Impact Scale <small>Severity X Likelihood</small>	Mitigation Safeguards	Residual Impact	Monitoring Parameter	Monitoring Location	Monitoring Frequency	Monitoring Responsibility
			<ul style="list-style-type: none"> <li>- No waste will be dumped at any location outside the proposed site boundary;</li> <li>- All hazardous waste will be separated from other wastes. Hazardous wastes will be disposed of through approved waste contractors;</li> <li>- Record all waste generated during the construction period will be maintained.</li> <li>- Training will be provided to personnel for identification, segregation, and management of waste.</li> </ul>					
<b>Operational Phase</b>								
<b>Air</b>	Chronic Respiratory health effects	2 X 3 = 6 <b>MEDIUM</b>	<ul style="list-style-type: none"> <li>- Ensure Fuel to Air Ratios are maintained;</li> <li>- Ensure power plant maintenance.</li> </ul>	2 X 1 = 3 <b>LOW</b>	CO and NOx	Project Site at Port Qasim	Quarterly	KE



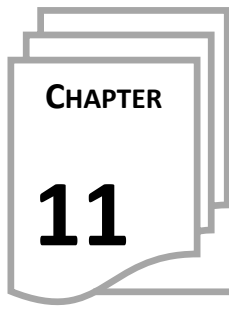
Aspect	Impact	Impact Scale <small>Severity X Likelihood</small>	Mitigation Safeguards	Residual Impact	Monitoring Parameter	Monitoring Location	Monitoring Frequency	Monitoring Responsibility
			<ul style="list-style-type: none"> <li>- Ensure Fuel to be used of approved quality.</li> </ul>					
<b>Noise</b>	<p>Power plant operations may result in elevated levels of noise which may result in following impacts:</p> <p>Stress</p> <p>Hypertension</p> <p>Hearing loss</p> <p>Headache</p>	<p>1 X 3 = 3</p> <p><b>LOW</b></p>	<ul style="list-style-type: none"> <li>- KE Employees accessing the area will always wear PPE's like ear protection muffs or ear plugs;</li> <li>- Proper maintenance of all the equipment to be utilized during operational phase will be maintained throughout the entire life cycle of the proposed project</li> <li>- Unauthorized personnel will not be allowed to access high noise areas.</li> </ul>	<p>1 X 2 = 2</p> <p><b>LOW</b></p>	Noise levels	Project Site at Port Qasim	Quarterly	KE
<b>Aquatic Environment</b>	Change in diversity of benthic community	<p>2 X 3 = 6</p> <p><b>MEDIUM</b></p>	<ul style="list-style-type: none"> <li>- Retain effluent prior to final discharge for treatment unless the quality remains within SEQs;</li> </ul>	<p>2 X 1 = 2</p> <p><b>LOW</b></p>	<p>MBI</p> <p>Marine outfall Parameters as per SEQs or SEPA requirement</p>	Benthic faunal sampling stations at outfall and intake channel of	Quarterly	KE

Aspect	Impact	Impact Scale <small>Severity X Likelihood</small>	Mitigation Safeguards	Residual Impact	Monitoring Parameter	Monitoring Location	Monitoring Frequency	Monitoring Responsibility
	Water pollution		<ul style="list-style-type: none"> <li>- The treated water can be reutilized for green areas</li> </ul>			BQPS-III at Port Qasim		
<b>Health &amp; Safety</b>	<p>Lack of awareness among general laborers about safety may lead to accidents</p> <p>Unskilled and untrained workers might cause harm to themselves and others</p> <p>Health hazards</p>	<p>2 X 3 = 6</p> <p><b>MEDIUM</b></p>	<ul style="list-style-type: none"> <li>- Ensure that all the safety and security procedures are in place and implemented in true spirit.</li> <li>- Ensure proper maintenance of firefighting systems during the entire life cycle of the proposed project.</li> <li>- Necessary training regarding safety aspects to the personnel working at the project site will be given.</li> <li>- Material Safety Data Sheet (MSDS) for chemicals, if any, will accompany the consignment.</li> <li>- The project developer must ensure implementation of proper HSE policy at all project locations so as to reduce the chances of occurrence of frequent hazards.</li> </ul>	<p>2 X 2 = 4</p> <p><b>MEDIUM</b></p>	<p>Record of Safety Talks</p> <p>Record of safety Incidents (Major &amp; Minor)</p> <p>Record of PPEs</p> <p>Visual Assessments</p>	All Project Installation and Modification Sites	Monthly	KE

Aspect	Impact	Impact Scale <small>Severity X Likelihood</small>	Mitigation Safeguards	Residual Impact	Monitoring Parameter	Monitoring Location	Monitoring Frequency	Monitoring Responsibility
<b>Livelihood and Economy</b>	<p>Proposed project will reduce the energy deficit of Karachi.</p> <p>people will benefit in form of employment and business activities</p> <p>Operational phase activities can cause health and safety risk</p>	<p>2 X 1 = 2</p> <p><b>LOW</b></p>	<ul style="list-style-type: none"> <li>- Possibility of recruitment of local workers having pertinent education skills will be explored;</li> <li>- Local businesses such as fabricators, maintenance service providers, food suppliers, transporters, etc., are likely to have business opportunities associated with the operation of the plant</li> <li>- Mechanism will be developed for local community engagement for complaints and suggestions;</li> </ul>	<p>1 X 1 = 1</p> <p><b>LOW</b></p>	<p>Complaint register and Grievance Redress Mechanism (GRM)</p> <p>Local Consultations records</p>		As and when required	KE

Aspect	Impact	Impact Scale <small>Severity X Likelihood</small>	Mitigation Safeguards	Residual Impact	Monitoring Parameter	Monitoring Location	Monitoring Frequency	Monitoring Responsibility
<b>Water and Waste Water</b>	Heated effluent discharge and untreated wastewater may result in seawater pollution and impacts on aquatic ecology	2 X 2 = 4 <b>MEDIUM</b>	<ul style="list-style-type: none"> <li>- Appropriate facilities to be provided for collection, storage and routing the wastewater streams to treatment plant and facilities are to be provided;</li> <li>- Appropriate sludge handling and disposal facilities are to be provided for waste treatment sludge.</li> <li>- Effluent sewers to be periodically cleaned and inspected for integrity;</li> <li>- Sanitary wastewater from all sections of the facility to be collected and routed to sanitary treatment system</li> <li>- All run off from the process area to be routed for treatment prior to disposal.</li> </ul>	2 X 1 = 2 <b>LOW</b>	Parameters as per SEQS or SEPA requirements	Water sampling stations at outfall and intake channel of BQPS-III at Port Qasim	Monthly	KE
<b>Solid waste</b>	Health impacts	2 X 3 = 6 <b>MEDIUM</b>	<ul style="list-style-type: none"> <li>- The solid waste management plan will be developed and facilities for collection, storage</li> </ul>	2 X 1 = 2 <b>LOW</b>	Within the site premises	All Project Installation and	Monthly	KE

Aspect	Impact	Impact Scale <small>Severity X Likelihood</small>	Mitigation Safeguards	Residual Impact	Monitoring Parameter	Monitoring Location	Monitoring Frequency	Monitoring Responsibility
	Unaesthetic view  Property loss  Unhygienic conditions		and transportation will be established and organized;  - A safe and designated area will be selected for disposal of waste and EPA certified contractors will be hired;  - Dumping of solid waste will be prohibited around the facilities.			Modification Sites		



# CONCLUSION

---

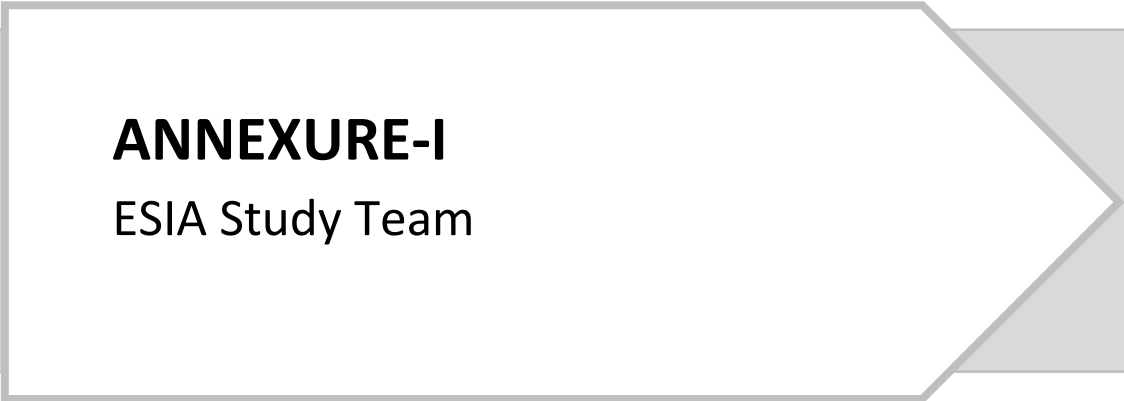
ESIA of the proposed 02 X 450 MW RLNG Based CCPGU project has achieved the following goals:

- Identification of national and provincial environmental regulatory requirements that apply to the proposed project activities;
- Identification of the environmental features of the proposed project area including the physical ,biological and social disturbance and likely impact of the project on the environment;
- Recommendation of appropriate mitigation measures that the project developer will incorporate and ensure as per this ESIA into the project to minimize the adverse environmental impacts.

Baseline physical, biological, socio-economic and cultural data and information was collected from a variety of primary and secondary sources, including field surveys, review of relevant literature and online publications. The collected data was used to organize profiles of the physical, biological and socio-economic environments, likely to be affected by the proposed project. Primary and secondary stakeholders were consulted through scoping meetings and consultation processes. These included communities, industries and institutional stakeholders. The aim of public consultation was to assure the quality, comprehensiveness and effectiveness of the ESIA as well as to ensure that the views and opinions of the local people were adequately taken into account in the decision making process. Further, an Environmental and Social Impact Assessment Report was made to highlight the potential impacts of the described proposed project on the area's physical, biological, socio- economic and cultural environments.

After assessing the proposed project activities and investigating the proposed project area, the environmental consultants, GEMS have concluded that:

**"If the activities are undertaken as described in this ESIA report, and the recommended mitigation measures along with environmental management plan is adopted specifically, the proposed BQPS-III 900 MW RLNG Based Combined Cycle Power Plant project will not result in any long-term impacts on the physical and biological environment of the proposed project area. Additionally the proposed project installation will significantly contribute towards reduced environmental pressure in terms of air quality as natural gas is recognized as a comparatively clean burning fuel and it emits less particulates and negligible SO<sub>2</sub>, as well as less NO<sub>x</sub> and CO<sub>2</sub> than other fossil fuels. It will also improve plant overall efficiency. Moreover the proposed project will create employment opportunities for local residents and play vital role in overcoming the power shortfall in the country, since Karachi is the industrial hub of Pakistan thus the continuous power supply will not only boost the industrial and economic development of country but also result in a long-term net beneficial impact on air quality as well as social wellbeing of local community".**



**ANNEXURE-I**  
ESIA Study Team

S.No	Name of Expert	Professional Qualification	Expertise	Proposed Position
1.	Dr. Sami-Uz-Zaman	Ph.D. Environmental Chemistry	Environmental Chemistry	Environmental Impact Mitigation Expert
2.	Mr. Saleem-Uz-Zaman	MBA	Project Management	Project Manager & Environmental Expert
3.	Mr. Shahid Lutfi	Bachelors of Engineering	ESIA Expert	ESIA Study Advisor
4.	Mr. Jibran Khalid Kidwai	MS Environmental Sciences	Project Coordination, ESIA , IEE and Monitoring and Auditing	Project Coordinator & Environmental Expert
5.	Dr. Shahid Amjad	Ph.D. Marine Biology	Marine Biology	Oceanographic/Marine Biology & Impact Mitigation Expert
6.	Mr. Rafi ulHaq	M.Sc Botany	Mangrove Ecology	Biodiversity Impact Mitigation Expert
7.	Mr. Qadiruddin	M.Sc Chemistry	Air Quality	Air Quality Monitoring Expert
8.	Mr. Ali Aslam	M.Sc Chemistry	Environmental Monitoring	Environmental Monitoring and Sampling Expert
9.	Dr. Ishratullah Siddiquie	Ph.D. Environmental Chemistry	Environmental Analytics	Environmental Sample Analysis Expert
10.	Engr. Muhammad Zohair	BE &M.Sc Environmental Sciences	Environmental and Social Impact Mitigation	Environmental and Social Impact Mitigation Expert
11.	Engr. Muneer Ahmed	ME Environmental Sciences	Green Energy	Green and Sustainable Energy Expert
12.	Engr. Kashif Noor	ME Environmental Sciences	Pollution Prevention Technologies	Environmental Impact Mitigation Expert



S.No	Name of Expert	Professional Qualification	Expertise	Proposed Position
13.	Mr. Zahid Raza	M.Sc Chemistry	Waste Management	Waste Management and Mitigation Expert
14.	Mr. Hafiz Baseer Khan	MS Environmental Sciences	Stakeholder Consultations	Environmental and Social Specialist
15.	Ms. Sundus Sohail	M.Sc Environmental Sciences	Stakeholder Consultations& Gender Assessment	Social & Gender Specialist
16.	Mr. Sikandar Ali	M.Sc Environmental Sciences and Zoology	Environment and Biodiversity	Environmental and Biodiversity Survey Expert
17.	Ms. Kanwal Khatri	M.Sc Environmental Sciences	Environmental Impact Assessment Technical Writing	Technical Writer
18.	Ms. Maria Kausar	M.Sc Environmental Sciences	Environmental Impact Assessment Technical Writing	Technical Writer
19.	Mr. Karim Akber	M.Sc Environmental Science	GIS and Air Dispersion Modeling	Air Dispersion Modeling Expert
20.	Mr. Nisar Khan	M.Sc Environmental Sciences	Environmental Sampling	Environmental Sampling and Monitoring Surveyor
21.	Mr. Tayyab Shafique	M.Sc Environmental Sciences	Environmental and Social Consultation	Environmental and Social Expert



**ANNEXURE-II**

SEQS 2015



# The Sindh Government Gazette

Published by Authority

---

**KARACHI THURSDAY JANUARY 28, 2016**

---

## PART-I

GOVERNMENT OF SINDH  
SINDH ENVIRONMENT PROTECTION  
AGENCY

### NOTIFICATION

NO.EPA/TECH/739/2014:- In exercise of the powers conferred under clause (g) of sub-section (1) of section 6 of the Sindh Environmental Protection Act, 2014, the Sindh Environmental Protection Agency, with the approval of the Sindh Environmental Protection Council, is pleased to establish the following standards:-

1. (1) These Standards may be called the Sindh Environmental Industrial Waste Water, Effluent, Domestic, Sewerage, Industrial Air Emission and Ambient Airs, Noise for Vehicles, Air Emissions for Vehicles and Drinking Water Quality Standards, 2015.

(2) These Standards shall come into force at once.

2. In these Standards, unless there is anything repugnant in the subject or context --

(a) "Government" means the Government of Sindh;

(b) "Standards" means the Sindh Environmental Quality Standards.

**SINDH ENVIRONMENTAL QUALITY STANDARDS FOR MUNICIPAL AND  
LIQUID INDUSTRIAL EFFLUENTS (mg/l, UNLESS OTHERWISE DEFINED)**

S. No.	Parameter	Standards		
		Into Inland Waters 3	Into Sewage Treatment <sup>(5)</sup> 4	Into Sea <sup>(1)</sup> 5
1.	Temperature 40 <sup>0</sup> C or Temperature Increase *	≤3 <sup>0</sup> C	≤3 <sup>0</sup> C	≤3 <sup>0</sup> C
2.	pH value (H <sup>+</sup> ) .	6-9	6-9	6-9
3.	Biochemical Oxygen Demand (BOD) <sub>5</sub> at 20 <sup>0</sup> C <sup>(1)</sup> ..	80	250	80**
4.	Chemical Oxygen Demand(COD) <sup>(1)</sup> ..	150	400	400
5.	Total Suspended Solids (TSS) ..	200	400	200
6.	Total Dissolved Solids (TDS)	3500	3500	3500
7.	Oil and Grease	10	10	10
8.	Phenolic compounds (as phenol)	0.1	0.3	0.3
9.	Chloride (as Cl <sup>-</sup> )	1000	1000	SC***
10.	Fluoride (as F <sup>-</sup> )	10	10	10
11.	Cyanide (as CN <sup>-</sup> ) total .	1.0	1.0	1.0
12.	An-ionic detergents (as MBAS) <sup>(2)</sup>	20	20	20
13.	Sulphate (SO <sub>4</sub> <sup>2-</sup> )	600	1000	SC***
14.	Sulphide (S <sup>2-</sup> )	1.0	1.0	1.0
15.	Ammonia (NH <sub>3</sub> )	40	40	40
16.	Pesticides <sup>(3)</sup>	0.15	0.15	0.15
17.	Cadmium <sup>(4)</sup> ..	0.1	0.1	0.1
18.	Chromium (trivalent and hexavalent) <sup>(4)</sup> ..	1.0	1.0	1.0
19.	Cooper <sup>(4)</sup> ..	1.0	1.0	1.0
20.	Lead <sup>(4)</sup>	0.5	0.5	0.5
21.	Mercury <sup>(4)</sup>	0.01	0.01	0.01
22.	Selenium <sup>(4)</sup>	0.5	0.5	0.5
23.	Nickel <sup>(4)</sup> ..	1.0	1.0	1.0
24.	Silver <sup>(4)</sup>	1.0	1.0	1.0
25.	Total toxic metals ..	2.0	2.0	2.0
26.	Zinc ..	5.0	5.0	5.0
27.	Arsenic <sup>(4)</sup>	1.0	1.0	1.0
28.	Barium <sup>(4)</sup>	1.5	1.5	1.5
29.	Iron ..	8.0	8.0	8.0
30.	Manganese ..	1.5	1.5	1.5
31.	Boron <sup>(4)</sup>	6.0	6.0	6.0
32.	Chlorine ..	1.0	1.0	1.0

**Explanations:**

1. Assuming minimum dilution 1:10 on discharge, lower ratio would attract progressively stringent standards to be determined by the Sindh Environmental Protection Agency. By 1:10 dilution means, for example that for each one cubic meter of treated effluent, the recipient water body should have 10 cubic meter of water for dilution of this effluent.
2. Methylene Blue Active Substances; assuming surfactant as biodegradable.
3. Pesticides include herbicides, fungicides, and insecticides.
4. Subject to total toxic metals discharge should not exceed level given at S. N. 25.
5. Applicable only when and where sewage treatment is operational and BOD<sub>5</sub>=80mg/l is achieved by the sewage treatment system.
6. Provided discharge is not at shore and not within 10 miles of mangrove or other important estuaries.
  - \*. The effluent should not result in temperature increase of more than 3<sup>0</sup>C at the edge of the zone where initial mixing and dilution take place in the receiving body. In case zone is not defined, use 100 meters from the point of discharge.
  - \*\* The value for industry is 200 mg/l
  - \*\*\* Discharge concentration at or below sea concentration (SC).

- Note:
1. Dilution of liquid effluents to bring them to the STANDARDS limiting values is not permissible through fresh water mixing with the effluent before discharging into the environment.
  2. The concentration of pollutants in water being used will be subtracted from the effluent for calculating the STANDARDS limits".

**“SINDH ENVIRONMENTAL QUALITY STANDARDS FOR INDUSTRIAL GASEOUS EMISSION (mg/Nm<sup>3</sup>, UNLESS OTHERWISE DEFINED).”**

S. No.	Parameter	Source of Emission	Standards
1	2	3	4
1.	Smoke	Smoke opacity not to exceed	40% or 2 Ringleman Scale or equivalent smoke number
2.	Particulate matter	(a) Boilers and Furnaces	
	(1)	(i) Oil fired	300
		(ii) Coal fired	500
		(iii) Cement Kilns	300

		(b) Grinding, crushing, Clinker coolers and Related processes, Metallurgical Processes, converter, blast furnaces and cupolas.	500
3.	Hydrogen Chloride	Any	400
4.	Chlorine	Any	150
5.	Hydrogen Fluoride	Any	150
6.	Hydrogen Sulphide	Any	10
7.	Sulphur Oxides <sup>(2)</sup> <sup>(3)</sup>	Sulfuric acid/ Sulphonic acid plants	
		Other Plants except power Plants operating on oil and coal	1700
8.	Carbon Monoxide	Any	800
9.	Lead	Any	50
10.	Mercury	Any	10
11.	Cadmium	Any	20
12.	Arsenic	Any	20
13.	Copper	Any	50
14.	Antimony	Any	20
15.	Zinc	Any	200
16.	Oxides of Nitrogen	Nitric acid Manufacturing unit.	3000
	(3)	Other plants except power plants operating on oil or coal:	
		Gas fired	400
		Oil fired	600
		Coal fired	1200

**Explanations:-**

1. Based on the assumption that the size of the particulate is 10 micron or more.
2. Based on 1 percent Sulphur content in fuel oil. Higher content of Sulphur will ease standards to be pro-rated.
3. In respect of emissions of Sulphur dioxide and Nitrogen oxides, the power plants operating on oil and coal as fuel shall in addition to Standards specified above, comply with the following standards:-

### A. Sulphur Dioxide

Sulphur Dioxide Background levels Micro-gram per cubic meter ( $\mu\text{g}/\text{m}^3$ ) Standards.

Background Air Quality (SO <sub>2</sub> Basis)	Annual Average	Max. 24-hours Interval	Criterion I Max. SO <sub>2</sub> Emission (Tons per Day Per Plant)	Criterion II Max. ground level increment to ambient (One year Average)
Unpolluted	<50	<200	500	50
Moderately Polluted*				
Low	50	200	500	50
High	100	400	100	10
Very Polluted**	>100	>400	100	10

\* For intermediate values between 50 and 100  $\mu\text{g}/\text{m}^3$  linear interpolations should be used.

\*\* No projects with Sulphur dioxide emissions will be recommended.

### B. Nitrogen Oxide

Ambient air concentrations of Nitrogen oxides, expressed as NO<sub>x</sub> should not be exceed the following:-

Annual Arithmetic Mean  $100\mu\text{g}/\text{m}^3$   
(0.05 ppm)

Emission level for stationary source discharge before missing with the atmosphere should be maintained as follows:-

For fuel fired steam generators as Nanogram ( $10^0$ -gram) per joule of heat input:

Liquid fossil fuel	..	..	..	130
Solid fossil fuel..	..	..	..	300
Lignite fossil fuel	..	..	..	260

Note:- Dilution of gaseous emissions to bring them to the STANDARDS limiting value is not permissible through excess air mixing blowing before emitting into the environment.

**Sindh Environmental Quality Standards for Motor  
Vehicle Exhaust and Noise**

**(i) For in-use Vehicles**

S. No.	Parameter	Standards (maximum permissible limit)	Measuring Method	Applicability
1	2	3	4	5
1.	Smoke	40% or on the Ringleman Scale during engine acceleration mode	To be compared with Ringleman Chart at a distance of 6 meters or more.	Immediate effect
2	Carbon Monoxide	6 %	Under idling conditions: Non-dispersive infrared detection through gas analyzer.	
3.	Noise	85 db (A)	Sound-meter at 7.5 meter from the source.	



For new Vehicles

**EMISSION STANDARDS FOR DIESEL VEHICLES**

(a) For passenger Cars and Light Commercial Vehicles (g/Km)

Type of Vehicle	Category/Class	Tiers	CO	HC+ NOx	PM	Measuring Method	Applicability
1	2	3	4	5	6	7	8
Passenger Cars.	M I: with reference mass (RW).	Pak-II, IDI	1.0	0.7	0.08		All imported and local manufactured
	up to 2500 kg. Cars with RW over 2500 kg. to meet NI Category standards	Pak-II DI	1.0	0.9	0.10	NEDC (ECE 15+ EUDCI)	Diesel vehicles with effect from 01-07-2012
Light Commercial Vehicles	NI-I (RW<1250 Kg)	Pak-II IDI	1.0	0.70	0.08		
		Pak-II DI	1.0	0.90	0.10		
	NI-II(1250kg< RW < 1700 Kg)	Pak-II IDI	1.25	1.0	0.12		
		Pak-II DI	1.25	1.3	0.14		
	NI-III(RW< 1700 Kg)	Pak-II IDI	1.50	1.2	0.17		
Pak-II DI		1.50	1.6	0.20			

## Parameter Standards (maximum permissible limit) Measuring method

Noise	85 db (A)	Sound-meter at 7.5 meters from the source
-------	-----------	---

## (b) For Heavy Duty Diesel Engines and Large Goods Vehicles (g/Kwh)

Type of Vehicle	Category/ Class	Tiers	CO	HC	NOx	PM	Measuring Method	Applicability
1	2	3	4	5	6	7	8	9
Heavy Duty Diesel Engines	Turks and Buses	Pak-II	4.0	1.1	7.0	0.15	ECE-R-49	All Imported and local manufactured diesel vehicles with the effect 1-7-2012
Large goods Vehicles	N2(2000 and up	Pak-II	4.0	7.0	1.10	0.15	EDC	

## Parameter Standards (maximum permissible limit) Measuring method

Noise	85 db (A)	Sound-meter at 7.5 meters from the Source
-------	-----------	---

## Emission Standards for Petrol Vehicles (g/km)

Type of Vehicle	Category/ Class	Tier	Co	HC+ NOx	Measuring Method	Applicability
1	2	3	4	5	6	7
Passenger Cars.	M I: with reference mass (RW). upto 2500 kg. Cars with RW over 2500 kg. to meet N1 Category standards	Pak-II	2.20	0.5	NEDC (ECE 15, EUDCL)	All imported and new models * locally manufactured petrol vehicles with effect from 1 <sup>st</sup> July, 2009**



SINDH ENVIRONMENTAL QUALITY STANDARDS FOR AMBIENT AIR

Pollutants	Time-weight average	Concentration in Ambient Air	Method of measurement
Sulphur Dioxide(SO <sub>2</sub> )	Annual Average* 24 hours**	80 µg/m <sup>3</sup> 120 µg/m <sup>3</sup>	Ultraviolet Fluorescence method
Oxides of Nitrogen as (NO)	Annual Average* 24 hours**	40 µg/m <sup>3</sup> 40 µg/m <sup>3</sup>	Gas Phase Chemiluminescence
Oxides of Nitrogen as (NO <sub>2</sub> )	Annual Average* 24 hours**	40 µg/m <sup>3</sup> 80 µg/m <sup>3</sup>	Gas Phase Chemiluminescence
O <sub>3</sub>	1 hour	130 µg/m <sup>3</sup>	Non dispersive UV absorption method
Suspended Particulate Matters(SPM) Respirable	Annual Average* 24 hours**	360 µg/m <sup>3</sup> 500 µg/m <sup>3</sup>	High Volume Sampling (Average flow rate not less than 1 l in 3/minutes)
Respirable Particulate Matter PM10	Annual Average* 24 hours**	120 µg/m <sup>3</sup> 150 µg/m <sup>3</sup>	B Ray absorption method
Respirable Particulate Matter PM2.5	Annual Average* 24 hours**	40 µg/m <sup>3</sup> *** 75 µg/m <sup>3</sup>	B Ray absorption method
Lead Pb	Annual Average* 24 hours**	1 µg/m <sup>3</sup> 1.5 µg/m <sup>3</sup>	ASS Method after sampling using EPM 2000 or equivalent filter paper
Carbon Monoxide(CO)	8 hours** 1 hours**	5 mg/m <sup>3</sup> 10 mg/m <sup>3</sup>	Non Dispersive Infra Red(NDIR) method

\*Annual arithmetic mean of minimum 104 measurements in a year taken twice a week, 24 hourly and at uniform interval.

\*\* 24 hourly/8 hourly values should be met 98% in a year, 2% of the time. It may exceed but not on two consecutive days.

\*\*\* Annual Average limit of  $40\mu/m^3$  or background annual average concentration plus allowable allowance of  $9\mu g/m^3$ , whichever is lower.

### Sindh Standards for Drinking Water Quality

Properties / Parameters	Standard Values for Sindh	WHO Standards	Remarks
<b>Bacterial</b>			
All water intended for drinking (e.Coli or Thermo tolerant Coliform bacteria)	Must not be detectable in any 100 ml sample	Must not be detectable in any 100 ml sample	Most Asian countries also follow WHO standards
Treated water entering the distribution system (E.Coli or thermo tolerant coliform and total coliform bacteria)	Must not be detectable in any 100 ml sample	Must not be detectable in any 100 ml sample	Most Asian countries also follow WHO standards
Treated water in the distribution system (E.coli or thermo tolerant coliform and total coliform and total coliform bacteria)	Must not be detectable in any 100 ml sample  In case of large supplies, where sufficient samples are examined, must not be present in 95% of the samples taken throughout any 12-month period	Must not be detectable in any 100 ml sample  In case of large supplies, where sufficient samples are examined, must not be present in 95% of the samples taken throughout any 12-month period	Most Asian countries also follow WHO standards
<b>Physical</b>			
Colour	≤ 15 TCU	≤ 15 TCU	
Taste	Non objectionable/Acceptable	Non objectionable/Acceptable	
Odour	Non	Non	

	objectionable/Acceptable	objectionable/Acceptable
Turbidity	< 5 NTU	< 5 NTU
Total hardness as CaCO <sub>3</sub>	< 500 mg/l	---
TDS	< 1000	< 1000
pH	6.5 - 8.5	6.5 - 8.5
<b>Chemical</b>		
<i>Essential Inorganic</i>		
	<i>mg/Litre</i>	<i>mg/Litre</i>
Aluminium (Al) mg/l	≤ 0.2	0.2

Properties / Performance	Standard Values for Pakistan	Who Standards	Remarks
Antimony (Sb)	≤ 0.005 (P)	0.02	
Arsenic (As)	≤ 0.05 (P)	0.01	Standard for Pakistan similar to most Asian developing countries
<b>Barium (Ba)</b>	0.7	0.7	
Boron (B)	0.3	0.3	
Cadmium (Cd)	0.01	0.003	Standard for Pakistan similar to most Asian developing countries
Chloride (Cl)	< 250	250	
Chromium (Cr)	≤ 0.05	0.05	
Copper (Cu)	2	2	
<i>Toxic Inorganic</i>			
	<i>mg/Liter</i>	<i>mg/Litre</i>	
Cyanide (CN)	≤ 0.05	0.07	Standard for Pakistan similar to Asian developing countries
Fluoride (F)*	≤ 1.5	1.5	
Lead (Pb)	≤ 0.05	0.01	Standard for Pakistan similar to most Asian developing countries
Manganese (Mn)	≤ 0.5	0.5	
Mercury (Hg)	≤ 0.001	0.001	
Nickel (Ni)	≤ 0.02	0.02	

Properties / Performance	Standard Values for Pakistan	Who Standards	Remarks
Nitrate (NO <sub>3</sub> )	≤ 0.50	50	
Nitrite (NO <sub>2</sub> )	≤ 3 (P)	3	
Selenium (SE)	0.01 (P)	0.01	
Residual chlorine	0.2-0.5 at consumer end 0.5-1.5 at source	---	
Zinc (Zn)	5.0	3	Standard for Pakistan similar to most Asian developing countries

Properties / Performance	Standard Values for Pakistan	Who Standards	Remarks
<b>Organic</b>			
Pesticides mg/L		PSQCA No. 4639-2004, Page No. 4 Table No. 3 Serial No. 20-58 may be consulted.***	Annex II
Phenolic compounds (as Phenols) mg/l.		≤ 0.002	
Polynuclear aromatic hydrocarbons (as PAH g/l.)		0.01 (By GC/MS method)	
<b>Radioactive</b>			
Alpha Emitters bq L or pCi	0.1	0.1	
Beta emitters	1	1	

\*\*\* PSQCA: Pakistan Standards Quality Control Authority

### Proviso:

The existing drinking water treatment infrastructure is not adequate to comply with WHO guidelines. The Arsenic concentrations in some parts of Sindh have been found high then Revised WHO guidelines. It will take some time to control arsenic through treatment process. Lead concentration in the proposed standards is higher than WHO Guidelines. As the piping system for supply of drinking water in urban centers are generally old and will take significant resources and time to get them replaced. In the recent past, Lead was completely phased out from petroleum

products to cut down Lead entering into environment. These steps will enable to achieve WHO guidelines for Arsenic, Lead, Cadmium and Zinc. However, for bottled water, WHO limits for Arsenic, Lead, Cadmium and Zinc will be applicable and PSQCA Standards for all the remaining parameters.

### Sindh Environmental Quality Standards for Noise

S. No.	Category of Area / Zone	Effective from 1 <sup>st</sup> Jan, 2015		Effective from 1 <sup>st</sup> January, 2015	
		Limit in dB(A) Leq *			
		Day Time	Night Time	Day Time	Night Time
1.	Residential Area (A)	65	50	55	45
2.	Commercial Area (B)	70	60	65	55
3.	Industrial Area (C)	80	75	75	65
4.	Silence Zone (D)	55	45	50	45

- Note:
1. Day time hours: 6:00 a.m to 10:00 p.m
  2. Night time hours: 10:00 p.m to 6:00 a.m
  3. Silence zone; Zones which are declared as such by the competent authority. An area comprising not less than 100 meters around hospitals, educational institutions and courts
  4. Mixed categories of areas may be declared as one of the four above-mentioned categories by the competent authority.
- \* dB(A) Leq; Time weighted average of the level of sound in decibels on scale A which is relatable to human hearing.

### 3. Repeal and Savings.

- (1) The provisions of the Statutory Notification dated 10<sup>th</sup> August, 2000 and 18<sup>th</sup> October, 2010, issued by the Ministry of Environment, Government of Pakistan, to the extent of the Province of Sindh are hereby repealed.
- (2) All actions taken, proceedings initiated shall be deemed to have been taken and initiated validly under the the provisions of these Rules.

DIRECTOR GENERAL  
SINDH ENVIRONMENTAL PROTECTION  
AGENCY



## **ANNEXURE-III**

Sindh Hazardous Substances Rules, 2014



GOVERNMENT OF SINDH  
SINDH ENVIRONMENTAL PROTECTION AGENCY

Karachi dated the 16<sup>th</sup> December, 2014.

## NOTIFICATION

**NO.EPA/TECH/739/2014** In exercise of the powers conferred by section 36 of the Sindh Environmental Protection Act, 2014, the Sindh Environmental Protection Agency, with the approval of the Government is pleased to make the following rules, namely:-

1. **Short title and commencement.** (1) These rules may be called the Hazardous Substances Rules, 2014.  
(2) They shall come into force at once.
2. **Definition.** (1) In these rules, unless there is anything repugnant in the subject or context
  - (i) "Act" means the Sindh Environmental Protection Act, 2014;
  - (ii) "Director-General" means the Director-General of the Agency;
  - (iii) "environmental impact assessment" means an environmental impact assessment as defined in clause (xv) of section 2;
  - (iv) "major accident" means an occurrence resulting from uncontrolled developments during industrial activity or from natural events which is likely to cause an adverse environmental effect, involving substantial loss of life and property;
  - (v) "section" means a section of the Act;
  - (vi) "Schedule" means Schedule to these rules; and
  - (vii) "worker" shall have the same meaning as defined in clause (h) of section 2 of the Factories Act, 1934 (XXV of 1934).(2) All other words and expressions used in these rules but not defined shall have the same meanings as are assigned to them in the Act.
3. **Substances prescribed as hazardous substances.** As provided in sub-clause (b) of clause (xxv) of section 2, substances listed in Schedule-I are hereby prescribed as hazardous substances.

4. **Application for licence.** An application for grant of licence under section 13 shall be filed with the Agency in Form-A of Schedule-II:

Provided that an applicant for grant of licence to import or transport a hazardous substance shall, in addition to information in Form-A, also provide details mentioned in sub-rule (1) of rules 20 and 21 respectively.

5. **EIA of project or industrial activity.** (1) An application for grant of licence filed under rule 4 shall be accompanied by an environmental impact assessment of the project or industrial activity involving generation, collection, consignment, transport, treatment, disposal, storage, handling or import of a hazardous substance in respect of which the licence is sought.

(2) The environmental impact assessment submitted by the applicant shall include –

- (a) a safety plan, containing information specified in sub-rule (1) of rule 17;
- (b) a waste management plan, if hazardous waste shall be generated by the project or industrial activity, containing information specified in sub-rule (1) of rule 19.

6. **Applicability of Sindh Environmental Protection Agency (Review of Initial Environmental Examination and Environmental Impact Assessment) Regulations 2014.** The environmental impact assessment accompanying an application for grant of licence shall be prepared, scrutinized, reviewed and decided in accordance with the provisions of the Sindh Environmental Protection Agency (Review Initial Environmental Examination and Environmental Impact Assessment) Regulations 2014.

7. **Issue of Licence.** (1) Where the Director General approves an application for grant of licence, the applicant shall be informed accordingly and directed to deposit with the Agency, a licence fee at the rate specified in Schedule-III.

(2) On receipt of the licence fee, the Agency shall issue a licence in Form-B of Schedule-II.

(3) If a licence is defaced, damaged or lost, duplicate thereof shall be issued on payment of such fee as specified in Schedule-III.

8. **Conditions of licence.** (1) A licence granted under section 13 shall be subject to the conditions of approval of the environmental impact assessment accompanying the application for licence.

(2) Without prejudice to the provisions of sub-rule(1), a licence granted under section 13 shall also be subject to the following conditions:-

- (a) the licensee shall employ qualified technical personnel having necessary knowledge and experience regarding the use, storage and handling of the hazardous substance, and safety precautions relating thereto;
- (b) the hazardous substance shall be packed and labeled in accordance with rule 9;
- (c) the premises of the licensee shall comply with the conditions laid down in

rule 10;

- (d) the licensee shall ensure compliance with the provisions of rules 11 and 12 regarding safety precautions;
- (e) the licensee shall provide necessary information, and where required training, to the persons to whom the hazardous substances are sold or delivered, regarding the use, storage and handling of the hazardous substances, and safety precautions relating thereto;
- (f) the licensee shall maintain a detailed record of the quantity, type, quality and origin of the hazardous substance and the names and addresses of the persons to whom the hazardous substances are sold or delivered; and
- (g) the licensee shall not extend his operation beyond the scope of the project or industrial activity in respect of which the environmental impact assessment has been submitted and approval granted.

(2) The Agency may, in the light of its review of the environmental impact assessment, require that the licensee maintain adequate insurance cover for any aspect of his operation.

(3) The licensee shall provide copy of approval from importing country under the international convention and protocol.

**9. Packing and labeling.-** (1) A container of a hazardous substance shall be of such size, material and design as to ensure that –

- (a) it can be stored, transported and used without leakage and safely;
- (b) the hazardous substance therein does not deteriorate in a manner as to render it more likely to cause, directly or in combination with other substances, an adverse environmental effect.

(2) The following information shall be printed conspicuously, legibly and indelibly on every container of a hazardous substance:-

- (a) name of the hazardous substance;
- (b) name, address and licence number of the licensee;
- (c) net contents (volume or weight);
- (d) date of manufacture and date of expiry, if any;
- (e) a warning statement comprising –
  - (i) the word “DANGER!” in red on a contrasting background;
  - (ii) a picture of a skull and cross-bones;
  - (iii) pertinent instructions for use, storage and handling and safety precautions relating thereto.
- (f) instructions regarding return or disposal of the empty container:

Provided that if the hazardous substance has an inner container as well as an outer container, the information shall be printed on both containers:

Provided further that if it is impracticable to print the aforesaid information on the container itself due to its size, material or design, the same shall be printed on a label or tag which shall be conspicuously affixed or attached to the container in such manner as to render it difficult to remove. The empty chemical containers or drums may not be used for other purposes:

- (g) basic instructions mentioning immediate steps to be taken in case of any accident or emergency, preferably in local language.

**10. Conditions for premises.** (1) The premises in which a hazardous substance is generated, collected, consigned, treated, disposed of, stored or handled shall -

- (a) comply with the conditions specified in Schedule-IV;
- (b) be fitted with a notice on the outer door or gate bearing the following information:-
  - (i) the words “DANGER ! HAZARDOUS SUBSTANCE!” in red, on a contrasting background; and
  - (ii) a prominent picture of a skull and cross-bones.

(2) In case of import of hazardous substances, proponent shall provide approval from Climate Change Division (International Convention Wing) Government of Pakistan.

**11. General safety precautions.** (1) A licensee shall ensure that the following safety precautions are conveyed to persons to whom the hazardous substances are sold or delivered:-

- (a) carefully read and follow the instructions and safety precautions printed on the container; (Urdu or local language translation of the same may be preferably given to the local buyers);
- (b) when opening the container, wear protective clothing and equipment including helmet or cloth cap, safety spectacles or goggles, respirator or mask, rubber or plastic gloves, and work boots, as may be required;
- (c) avoid contact of the hazardous substance with exposed skin or eyes, and if such contact occurs, wash the exposed area immediately and consult a doctor;
- (d) avoid contaminating clothing, gloves and footwear with the hazardous substance, and if such contamination occurs, remove the clothing, gloves and footwear immediately and wash the same thoroughly before reuse;
- (e) do not eat, drink or smoke in the vicinity of hazardous substances.

(2) The general safety precautions mentioned in sub-rule (1) shall be in addition to such other specific precautions or measures that may be required to be conveyed by the licensee for a particular hazardous substance. The licensee will be bound to inform the Agency, the details of his subsequent consignments as the licence will be issued for a period of one year under section 13.

**12. Safety precautions for workers.** A licensee shall ensure that the following safety

precautions are taken in respect of workers employed by him for handling hazardous substances:-

- (a) No worker aged below eighteen years or over sixty years shall be employed for any job involving physical handling of hazardous substances.
  - (b) All workers shall be thoroughly trained in safety precautions for handling hazardous substances and shall be supervised by qualified supervisors.
  - (c) Protective clothing and equipment comprising helmet or cloth cap, safety spectacles or goggles, respirators or masks, rubber or plastic gloves and work-boots shall be available for all workers who may be exposed to any hazardous substance, and no worker shall be permitted on job unless and until he is wearing such protective clothing and equipment.
  - (d) Adequate supply of water shall be made available to the workers for personal washing as well as for washing their protective clothing and equipment.
  - (e) Protective clothing and equipment of the workers shall be washed and cleaned as often as may be required to ensure their efficacy.
  - (f) No worker shall be permitted to eat, drink or smoke till he has removed his protective clothing and equipment, washed his hands and face, and left the place of work.
  - (g) All fire-fighting, emergency and safety equipment shall be frequently checked and properly maintained.
  - (h) First-aid medical facility equipped with required antidotes shall be available in the premises, supervised by trained staff.
  - (i) Medical check-up of all workers shall be carried out at the time of employment and at least once a year thereafter.
  - (j) A record of every worker shall be maintained containing, amongst other details, his name and address, his medical check-up history, and the hazardous substances handled by him.
13. **Validity of licence.** A licence issued under rule 7 shall be valid for a period of one year from the date of issue:
- Provided that if an application for renewal is made under rule 14, the licence shall continue to remain valid till the application for renewal is decided.
14. **Renewal of licence.** An application for renewal of licence shall also be made to the Federal Agency in Form-A of Schedule II, at least 30 days before the date of its expiry.
- (i) An application for renewal shall be accompanied by a brief update of the original environmental impact assessment, unless changes in circumstances require

submission of a fresh environmental impact assessment.

- (ii) the fee for renewal of licence shall be as provided in Schedule-III, and the licence issued on receipt thereof shall also be in Form-B of Schedule II.
- (iii) the fee for duplicate copy of licence shall be as provided in Schedule-III and the licence issue on the receipt thereof shall also be in Form-B of Schedule-II.

**15. Cancellation of the licence.** (1) Notwithstanding anything contained in these rules, if at any time on the basis of information or report received or inspection carried out, the Agency is of the opinion that the conditions of the licence have not been complied with, or that the information supplied by the licensee in his application or approved environmental impact assessment is incorrect, it shall issue notice to the licensee to show cause, within two weeks of receipt thereof, why the licence should not be cancelled.

(2) If no reply is received or if the reply is considered unsatisfactory, the Agency may, after giving the licensee an opportunity of being heard -

- (i) require the licensee to take such measures and to comply with such conditions within such period as it may specify, failing which the licence shall stand cancelled; or
- (ii) cancel the licence.

(3) On cancellation of the licence under sub-rule (2), the licensee shall cease his operations forthwith.

(4) The action taken under this rule shall be without prejudice to any other action that may be taken against the licensee under the Act or rules or regulations or any other law for the time being in force.

**16. Entry, inspection and monitoring.** (1) For the purposes of verification of any matter relating to the conditions of the licence, duly authorized staff of the Agency shall be entitled to enter and inspect the premises in which the hazardous substance is being generated, collected, consigned, treated, disposed of, stored or handled:

Provided that the Agency shall inspect the premises at least once a year.

(2) The licensee shall ensure cooperation of his staff at the premises to facilitate the inspection mentioned in sub-rule (1).

(3) The licensee shall provide such information as may be required by the Agency for effective monitoring of compliance by the licensee with the conditions of the licence.

**17. Safety plan.** (1) The safety plan to be submitted by an applicant under clause (a) of sub-rule (2) of Rule 5 shall include –

- (a) an analysis of major accident hazards relating to the hazardous substance involved;
- (b) an assessment of the nature and scope of the adverse environmental effects

likely to be caused by major accidents;

- (c) a description of the safety equipment and systems installed and safety precautions taken; and
- (d) a description of the emergency measures proposed to be taken on and off the premises of the applicant to control a major accident, and to mitigate its adverse environmental effect.

(2) Before issue of the licence, the Agency shall, in consultation with other relevant Government Agencies and Departments including the licensee, review the safety plan to ensure that it covers all anticipated contingencies and all emergencies likely to result from a major accident involving the hazardous substance involved, and that the concerned Government Agencies, Departments and the licensee are aware of their specific responsibilities thereunder.

- (3) After issue of the licence, the licensee shall ensure that all persons liable to be affected by the approved safety plan are informed of the relevant provisions thereof.

18. **Notification of major accident.** (1) Where a major accident occurs on the premises of a licensee, the licensee shall immediately notify the Agency concerned and shall submit within twenty four hours and weekly thereafter, a report in Schedule-V.

(2) On receipt of the report under sub-rule (1), the Agency shall require the licensee to carry out a detailed environmental audit of the major accident and initiate necessary action, in accordance with the approved safety plan or otherwise, to control the major accident, mitigate its adverse environmental effect and prevent it from recurring.

19. **Waste management plan.** (1) The waste management plan, if required to be submitted by an applicant under clause (b) of sub-rule (2) of rule 5, shall -

- (a) provide for the generation, collection, transport and disposal of the hazardous waste in a manner which shall protect against an adverse environmental effect;
- (b) ensure that the hazardous waste is not mixed with non-hazardous waste, unless the applicant can prove that such mixing will better protect against an adverse environmental effect.

(2) The waste management plan shall be reviewed every year by the licensee to take



into consideration the development of new technologies and management practices which can better protect against an adverse environmental effect, and if required revised waste management plan and fresh environmental impact assessment shall be submitted with the application for renewal of licence.

(3) If the waste management plan provides for export of the hazardous waste, such export shall only be allowed if it is in accordance with a bilateral, multilateral or regional agreement or arrangement that conforms to the requirements of Article 11 of the Convention on the Control of Transboundary Movements of Hazardous Waste and Their Disposal, Basel, 1989.

(4) The licensee shall inform the Agency on a yearly basis about -

(a) the quantity and characteristics of hazardous waste generated in the previous year; and

(b) progress regarding implementation of the waste management plan.

20. **Import of hazardous substances.** (1) The applicant shall, for grant of licence to import a hazardous substance in addition to the information contained in Form-A of Schedule II, also provide the following details:-

(i) port of entry into Province of Sindh;

(ii) particulars of transport from exporting country to Pakistan;

(iii) quantity of hazardous substance being imported;

(iv) complete information pertaining to safety precautions to be adopted; and

(v) the purpose for which the hazardous substance is to be utilized, along with environmental impact assessment in respect thereof, if required under rule 5.

(vi) Licensee shall provide copy of approval from Climate Change Division (International Convention Wing) Government of Pakistan under the provisions of International Convention and Protocol.

(2) If the licence applied for is granted, the concerned Federal Agency or Ministry and the Agency and port authority concerned, shall ensure that proper steps are taken for safe off-loading, handling and storage of the hazardous substance on arrival at the port.

21. **Transport of hazardous substances.** (1) The applicant shall, for grant of licence for transport of a hazardous substance in addition to the information contained in Form-A of Schedule II, also provide the following details :-

- (i) name and address of the person from whom the hazardous substance is to be collected;
- (ii) name and address of the person to whom the hazardous substance is to be delivered;
- (iii) quantity of hazardous substance to be transported;
- (iv) mode of transport, including full particulars and specifications of the motor vehicles or other conveyance;
- (v) route to be adopted between the origin and destination;
- (vi) date and time of proposed transportation;
- (vii) nature of waste which may be liquid or solid and its toxicity along with Material and Safety Data Sheet (MSDS); and
- (viii) contingency or emergency response plan.

(2) If the licence applied for is granted, the Agency shall ensure that the Government Departments or Agencies concerned are informed of the relevant particulars of the transportation, for taking necessary safety precautions and other measures.

22. **Other approvals.** The issuance of a licence under section 13 read with rule 7 shall not absolve the licensee to obtain any other approval or consent that may be required under any law for the time being in force.

**DIRECTOR GENERAL  
SINDH ENVIRONMENTAL PROTECTION AGENCY**

**SCHEDULE-I**  
(see Rule 3)

**List of Prescribed Hazardous Substances or Any Other Synthetically Chemical**

<b>S. NO.</b>	<b>NAME OF CHEMICALS</b>	<b>CAS. NO</b>
1.	Acetaldehyde	75-07-0
2.	Acetic acid	64-19-7
3.	Acetic anhydride	108-24-7
4.	Acetone	67-64-1
5.	Acetone cyanohydrins	75-86-5
6.	Acetone Thiosemicarbazide	
7.	Acetylene	74-86-2
8.	Acetyl chloride	75-36-5
9.	Acrolein	107-02-8
10.	Acrylamide	79-06-1
11.	Acrylonitrile	107-13-1
12.	Adiponitrile	111-69-3
13.	Aldicarb	116-06-3
14.	Aldrin	309-00-2
15.	Allyl alcohol	107-18-6
16.	Allyl amine	107-11-9
17.	Allyl chloride	107-05-1
18.	Amino biphenyl	92-67-1
19.	3-Amino-1, 2,4 triazole	61-82-5
20.	Aminopterin	
21.	Amiton	78-83-5
22.	Amiton dialate	
23.	Ammonia	7664-41-7
24.	Ammonium chloride	12125-02-9
25.	Ammonium sulphamate	7773-06-0
26.	Aniline	62-53-3
27.	Aniline 2,4,6-Trimethyl	
28.	Anthraquinone	84-65-1
29.	Antimony & Compounds	7440-36-0
30.	Arsenic & Compounds	7440-38-2
31.	Arsine	7784-42-1
32.	Asbestos	1332-21-4
33.	Azinpho-ethyl	
34.	Azinphos methyl	86-50-0
35.	Bacitracin	

S. NO.	NAME OF CHEMICALS	CAS. NO
36.	Barium and Compounds	513-77-9
37.	Benzal chloride	98-87-3
38.	Benzenamine 3-Trifluoromethyl	
39.	Benzene	71-43-2
40.	Benzene sulfonyl chloride	98-09-9
41.	Benzene 1- (chloromethyl) -4 Nitro	
42.	Benzene arsenic acid	
43.	Benzidine and Salt	92-87-5
44.	Benzimidazole, 4,5-dichloro-2 (Trifluoromethyl)	
45.	Benzyl chloride	100-44-7
46.	Beryllium and Compounds	7440-41-7
47.	Bis (2-chloroethyl) Sulphide	?
48.	Bis (chloroethyl) ketone	?
49.	Bis (Tert-butyl peroxy) cyclohexane	?
50.	Bis (Tert-butyl peroxy) butane	?
51.	Bis (2,4,6-Trinitrophenylamine)	?
52.	Bromo chloro methane	74-97-5
53.	Bromoform	75-25-2
54.	Butyl amine tert	75-64-9
55.	Butyl-n-mercaptan	109-79-5
56.	Cadmium and Compounds	7440-43-9
57.	Calcium arsenate	7778-44-1
58.	Calcium Cyanamide	156-62-7
59.	Camphenchlor Toxaphene)	8001-35-2
60.	Cantharidin	?
61.	Captan	133-06-2
62.	Carbachol chloride	?
63.	Carbaryl	63-25-2
64.	Carbofuran	1563-66-2
65.	Carbon tetrachloride	56-23-5
66.	Carbon disulphide	75-15-0
67.	Carbon monoxide	630-08-0
68.	Cellulose nitrate	9004-70-0 ?
69.	Chlordane	12789-03-6
70.	Chlorinated benzene	108-90-7
71.	Chlorine	7782-50-5
72.	Chlorine oxide	10049-04-4
73.	Chlorine trifluoride	7790-9102
74.	Chloroacetaldehyde	107-20-0
75.	Chlorobenzene	108-90-7

<b>S. NO.</b>	<b>NAME OF CHEMICALS</b>	<b>CAS. NO</b>
76.	Chloroform	67-66-3
77.	Chloromethyl methylether	107-30-2
78.	Chloronitrobenzene	88-73-3
79.	Chloroethyle Vinyl ether	110-75-8
80.	Chromium and Compounds	7440-47-3
81.	Cobalt and Compounds	7440-48-4
82.	Copper and compounds	7440-50-8
83.	Crotonaldehyde	123-73-9
84.	Cumene	98-82-8
85.	Cyanides and Compounds	151-50-8
86.	Cyclohexane	110-82-7
87.	DDT	50-29-3
88.	Demeton	298-03-3
89.	Dichlorobenzene	95-50-1
90.	Dichloroethyl ether	111-44-4
91.	Dichlorophenol-2.6	87-65-0
92.	Dichlorophenol-2.4	120-83-2
93.	Dichloropropene-1,3	142-28-9
94.	Dichloropropionic acid	127-20-8
95.	Dichlorvos	62-73-7
96.	Dieldrin	60-57-1
97.	Dimethyl hydrazine	57-14-7
98.	Dimethyl phenol 2,4	105-67-9
99.	Dimethylamine	109-89-7
100.	Dimethylaniline	121-69-7
101.	Dinitrophenol 2-4	51-28-5
102.	Dinitrotoluenes	121-14-2
103.	Dinoseb	88-85-7
104.	Dinitrobenzene	528-29-0
105.	Dioxane-p	123-91-1
106.	Dioxathion	78-34-2
107.	Diquat	85-00-7
108.	Endosulfan	115-29-7
109.	Endrin	72-20-8
110.	Epichlorohydrine	106-89-8
111.	Ethion	563-12-2
112.	Ethyl acetate	141-78-6
113.	Ethyl benzene	100-41-4
114.	Ethyl amine	75-04-7
115.	Ethyl ether	60-29-7

<b>S. NO.</b>	<b>NAME OF CHEMICALS</b>	<b>CAS. NO</b>
116.	Ethyl methacrylate	97-63-2
117.	Ethylene dichloride	107-06-2
118.	Ethylene dibromide	106-93-4
119.	Ethylene diamine	107-15-3
120.	Ethylene oxide	75-21-8
121.	Ethylenimine	151-56-4
122.	Fluorine	7782-41-4
123.	Formaldehyde	50-00-0
124.	Formic acid	64-18-6
125.	Furfural	98-01-1
126.	Heptachlor	76-44-8
127.	Hexachlorobenzene	118-74-1
128.	Hexachlorocyclohexan (Lindane)	608-73-1
129.	Hexachlorocyclopentadiene	77-47-4
130.	Hydrochloric acid	7647-01-0
131.	Hydrogen sulphide	7783-06-4
132.	Hydrogen cyanide	74-90-8
133.	Hydrogen fluoride	7664-39-3
134.	Iridium tetrachloride	?
135.	Isobutyl alcohol	?
136.	Lead (Inorganic)	7439-92-1
137.	Lead arsenate	7784-40-9
138.	Lindane	58-89-9
139.	Magnesium powder or ribbon	7439-95-4 ?
140.	Malathion	121-75-5
141.	Maleic anhydride	108-31-6
142.	Malononitrile	109-77-3
143.	Mercury and Compounds	502-39-6
144.	Methoxy chloride	
145.	Methyl alcohol	67-56-1
146.	Methyl amine	74-89-5
147.	Methyl bromide (Bromomethane)	74-83-9
148.	Methyl chloride	74-87-3
149.	M ethyl chloroform (1,1,1-Trichloroethane)	137-5-3
150.	Methyl ethyl ketone peroxide	1338-23-4
151.	Methyl isocyanate	624-83-9
152.	Methyl methacrylate monomer	80-62-6
153.	Methyl Parathion	298-00-0
154.	Mevinphos	7786-34-7
155.	Molybdenum and Compounds	7439-98-7

<b>S. NO.</b>	<b>NAME OF CHEMICALS</b>	<b>CAS. NO</b>
156.	Monocrotophos	6973-22-4
157.	Butyl acetate	123-86-4
158.	Butyl alcohol	71-36-3
159.	Naled	300-76-5
160.	Naphthalene	91-20-3
161.	Naphthyl amine	91-51-8
162.	Nickel salts	7440-02-0
163.	Nicotine	54-11-5
164.	Nitric acid	7697-37-2
165.	Nitric oxide	10102-43-9
166.	Nitro benzene	98-95-3
167.	Nitrochlorobenzene	100-00-5
168.	Nitrocyclohexane	
169.	Nitrogen dioxide	10102-44-0
170.	Nitrogen trifluoride	7783-54-2
171.	Nitrophenols	88-75-5
172.	Nitropropane-2	79-46-9
173.	Nitroso dimethyl amine	62-75-9
174.	Cresol	1319-77-3
175.	Nitroaniline	100-01-6
176.	Osmium tetroxide	20816-12-0
177.	Oxygen (Liquid)	7727-37-9
178.	Oxygen difluoride	7783-41-7
179.	Ozone	10028-15-6
180.	Paraoxon (diethyl-4 nitrophenyphosphate)	
181.	Parathion	56-38-2
182.	Pentaborane	19624-22-7
183.	Pentachlorobenzene	608-93-5
184.	Pentachlorophenol	87-86-5
185.	Pentabromophenol	
186.	Phenol	108-95-2
187.	Phenol,2,2-thiobis (4,6-dichloro)	
188.	Phenol,2,2-thiobis (4 chioro 6 methyl phenol)	
189.	Phenol, 3- (1- methyl-ethyl)- methylcarbamate	
190.	Phorate	298-02-2
191.	Phosgene	75-44-5
192.	Phosphoric acid	7664-38-2
193.	Phosphorus	7723-14-0
194.	Phosphorus oxychloride	10025-87-3
195.	Phosphorus pentasulphide	1314-80-3

S. NO.	NAME OF CHEMICALS	CAS. NO
196.	Phosphorus trichloride	7719-12-2
197.	Phthalic anhydride	85-44-9
198.	Picric acid (2,4,6-trinitrophenol)	88-89-1
199.	Polychlorinated biphenyls (PCBs)	1336-36-3
200.	Propionic acid	79-09-4
201.	Propargyl alcohol	107-19-7
202.	Propylene oxide	75-56-9
203.	Pyrethrins	8003-34-71
204.	Pyridine	110-86-1
205.	Quinone	106-51-4
206.	Sodium azide	26628-22-8
207.	Sodium fluoro-acetate	62-74-8
208.	Sodium hydroxide	1310-73-2
209.	Strychnine	57-24-9
210.	Styrene	100-42-5
211.	Sulfuric acid	7664-93-9
212.	Tert- Butyl peroxyacetate	
213.	Tetra ethyl pyrophosphate	107-49-3
214.	Tetra nitromethane (Rocket Industry)	509-14-8
215.	Tetra-chlorodibenzo-p-dioxin, 1,2,3,7,8 (TCDD)	1746-01-6
216.	Tetraethyl lead	78-00-2
217.	Thallic oxide	
218.	Titanium powder	7440-32-6
219.	Toluene	108-88-3
220.	Toluene 2,4-diisocyanate	584-84-9
221.	Toxaphene	8001-35-2
222.	Trans-1,4-dichloro-butene	
223.	Trichloroethylene	79-01-6
224.	Trichlorophenols	95-95-4
225.	Trichlorophenoxy acetic acid 2,4,5 triethylamine	93-76-5
226.	Trichlorophenol 2,3,6	933-75-5
227.	Trichlorophenol 2,4,5	95-95-4
228.	Triethylamine	121-44-8
229.	Triethylene melamine	
230.	Trinitrobenzene	99-35-4
231.	Trinitrotoluene (TNT)	118-96-7
232.	Turpentine	8006-64-2
233.	Uranium and compounds	7440-61-1
234.	Vanadium and compounds	7440-62-2
235.	Vinyl acetate	108-05-4



<b>S. NO.</b>	<b>NAME OF CHEMICALS</b>	<b>CAS. NO</b>
236.	Vinyl chloride	75-01-4
237.	Vinylidene chloride	75-35-4
238.	Warfarin	81-81-2
239.	Xylene	1330-20-7
240.	Xylidine	1300-73-8
241.	Zinc chloride	7646-85-7
242.	Zirconium and compounds	7440-67-7
243.	Any other substance declared hazardous by Sindh EPA	

**SCHEDULE-II**  
**FORM A**  
**(see Rule 4)**

**Application for grant/renewal of licence for hazardous substance**

I/we [*name(s)* \_\_\_\_\_] of [*address* \_\_\_\_\_] hereby apply for grant/ renewal of licence to generate/collect/consign/transport/treat/dispose of/ store/ handle/ import (delete words inapplicable) the following hazardous substance

\_\_\_\_\_

at my/our premises situated at [*address* \_\_\_\_\_].

I/we have read, and hereby undertake to comply with, all applicable provisions of the Sindh Environmental Protection Act, 2014 and rules and regulations made thereunder, including and in particular the Hazardous Substances Rules, 2014.

I/we submit herewith the following documents:-

- (i) Environmental Impact Assessment (EIA) of the project/industrial activity involving the above-mentioned hazardous substance, including safety plan. Waste management plan is/is not included. [*delete word(s) inapplicable*].
- (ii) Approved building plan of the premises mentioned above.
- (iii) List of machinery and equipment installed/proposed to be installed.
- (iv) List of qualified personnel and number of workers employed/proposed to be employed.

Date: \_\_\_\_\_

\_\_\_\_\_  
Applicant

**SCHEDULE-II**  
**FORM B**  
**(See Rule 7)**

**Licence for hazardous substance**

M/s [*name* \_\_\_\_\_] of [*address* \_\_\_\_\_] is hereby granted licence to generate / collect / consign / transport / treat / dispose of/ store /handle /import (*delete words inapplicable*) the following hazardous substance –

\_\_\_\_\_

at its premises situated at [*address* \_\_\_\_\_] subject to the conditions specified below –

- 1) the following conditions of approval of the EIA accompanying the application for licence –

\_\_\_\_\_

- 2) the conditions specified in Rule 8 of the Hazardous Substances Rules, 2014.

- 3) The following additional conditions –

\_\_\_\_\_

This licence shall be valid for a period of one year from the date given below.

Date: \_\_\_\_\_

**Director-General**  
**Sindh Environmental Protection Agency**

**SCHEDULE III**  
**(see Rule 7)**  
**Licence fees**

<b>Description</b>	<b>Fee</b>
Licence Fee	Rs.50,000
Renewal Fee	Rs.25,000
Duplicate Fee	Rs. 10,000

**SCHEDULE IV**  
**(see rule 10)**

**Conditions for premises**

**1. Location**

The premises shall not be located -

- (a) in a congested, residential, commercial or office area;
- (b) in small lanes or bye-lanes;
- (c) close to drinking water sources; or
- (d) in an area liable to flooding.

**2. Building**

The building shall -

- (a) be soundly constructed with good ventilation and protection against direct sunlight;
- (b) have well-maintained electrical installations;
- (c) have walls protected by non-flammable or slow-burning material;
- (d) have fire-resistant doors fitted with self-closing system;
- (e) have smooth, crack-free floors impermeable to liquids;
- (f) have drains, if absolutely necessary, which do not connect directly with the sewerage system;
- (g) have signs indicating location of emergency exits, escape routes, and fire-fighting equipment, prohibition of smoking, and safety precautions; and
- (h) have proper washing facilities with adequate supply of water.

**SCHEDULE V**

(see rule 18)

**Notification of major accident**

**Report no.** \_\_\_\_\_

1. Name and address of licensee \_\_\_\_\_
2. Licence no. and date \_\_\_\_\_ Nature of industrial activity mentioning Hazardous substance involved.  
\_\_\_\_\_
3. Description of major accident -
  - (a) Date and time \_\_\_\_\_
  - (b) Exact location \_\_\_\_\_
  - (c) Process/operation during which accident took place \_\_\_\_\_
  - (d) Type and circumstances of accident and estimated quantity of hazardous substance involved.  
\_\_\_\_\_
4. Known causes of the major accident.  
\_\_\_\_\_
5. Nature and extent of damage –
  - (a) In the premises; \_\_\_\_\_
  - (b) Outside the premises. \_\_\_\_\_
6. Description of emergency measures already taken.  
\_\_\_\_\_
7. Description of further measures proposed to be taken to –
  - (a) mitigate adverse effects \_\_\_\_\_
  - (b) prevent recurrence \_\_\_\_\_
8. Any other relevant information. \_\_\_\_\_  
\_\_\_\_\_

Date: \_\_\_\_\_

*Time:* \_\_\_\_\_

*Licensee*

---



**ANNEXURE-IV**

HSEQ Policy

## CORPORATE HSEQ POLICY

### TITLE

KE - HSEQ POLICY-001	05	1 <sup>st</sup> December 2014	1 of 1	CORPORATE HSEQ
DOCUMENT NO.	VERSION	DATE OF VERSION	PAGE	ISSUING DEPARTMENT

## HSEQ POLICY

We at KE are committed to surpassing the requirements and expectations of our customers, improving our Health, Safety, Environment and Quality performance and minimising the impact of our activities on the environment by:

- Complying with applicable legal and other requirements to which our company subscribes.
- Embedding the Health, Safety, Environment and Quality requirements in our routine and non-routine activities.
- Preventing injuries and ill health to personnel affected by our activities through a proactive system of risk management.
- Conserving natural resources and reducing the carbon footprint of activities by proactively assessing their environmental impact and mitigating their adverse effects.
- Ensuring competency of employees by providing them with adequate training, information, instructions and supervision.
- Communicating with stakeholders to ensure better understanding of our HSEQ policies, standards, programmes and performance.
- Ensuring continual improvement through a system of performance planning, measurement and reviews.

KE employees are at the forefront of this policy; for its successful implementation they shall demonstrate their HSEQ consciousness by practicing their assigned safety roles and responsibilities. The policy shall also reinforce our standards of nurturing and developing our substantial talent pool, building shareholder value through performance excellence & improved financial results and measuring customer satisfaction by providing reliable, safe and cost effective services.

It is my firm belief and a core business value that all accidents and work related ill health is preventable. To achieve this, I shall ensure that timely decisions are taken and resources provided to demonstrate our commitment on implementing our HSEQ vision and strategy.



**TAYYAB TAREEN**  
CHIEF EXECUTIVE OFFICER  
Date: 1<sup>st</sup> December'14





**ANNEXURE-V**

Traffic Management Plan

# TRAFFIC MANAGEMENT PLAN

A simplified traffic management plan has been developed for assistance of Suresh Kumar Builders for their propose project namely Frere Excellency. However, it is important to note that this plan is specifically designed for construction phase only. For devising a comprehensive traffic management plan for operational phase a detailed study based on traffic survey in coordination with relevant traffic police section must be carried out in order to mitigate traffic congestion after development of proposed project.

Aspect	Measures to be taken	Implementation	Responsibility
<b>Route Diversions</b>	i. Plan and designate entry and exit points for the project sites which will be required by heavy vehicles during construction phase.	Construction Phase	Contractor
	ii. Allocate temporary alternative route considering usual traffic volumes and road carrying capacities and feasibility of general public with consultation and approval of City Traffic Police Karachi.	Construction Phase	Contractor
	iii. Conditions of roads are to be checked prior to selecting routes for both general public and construction vehicles.	Construction Phase	Contractor
	iv. Provide a separate clear path for emergency care vehicles like ambulances and fire brigades.	Construction Phase	Contractor
<b>Construction site demarcation</b>	i. Ensure proper fencing where storage, campsites and other facilities are located to avoid unauthorized access.	Construction Phase	Contractor
	ii. Cordon of the construction site by reflector cones at least 50 m before the actual working site to alert all people passing by.	Construction Phase	Contractor
	iii. Allocate appropriate parking areas for the use of employees including contractors and for heavy machineries within the project site	Construction Phase	Contractor

<b>Aspect</b>	<b>Measures to be taken</b>	<b>Implementation</b>	<b>Responsibility</b>
<b>Signage</b>	<ul style="list-style-type: none"> <li>i. Display sign boards and banners about traffic diversions at places on detour routes.</li> <li>ii. Ensure use of Traffic Control Devices (TCDs) like reflectors, hazard cones and sign boards as required at main roads.</li> <li>iii. Construction Vehicles will be installed with revolving hazard lights and hooters for signaling operation when in use.</li> </ul>	<p>Construction Phase</p> <p>Construction Phase</p> <p>Construction Phase</p>	<p>Contractor/Project Developer</p> <p>Contractor/Project Developer</p> <p>Contractor/Project Developer</p>
<b>Speed</b>	<ul style="list-style-type: none"> <li>i. Install temporary speed bumps / humps near work zone areas and especially near residential areas with consultation and approval of City Traffic Police Karachi.</li> <li>ii. Ensure all vehicles in the area maintain speeds up to 30 km/hr.</li> </ul>	<p>Construction Phase</p> <p>Construction Phase</p>	<p>Contractor/ Project Developer</p> <p>Contractor</p>
<b>Timings</b>	<ul style="list-style-type: none"> <li>i. Undertake construction activities that are audible at any residential receptor, between the following hours: <ul style="list-style-type: none"> <li>🚧 7:00am to 6:00pm, Mondays to Fridays.</li> <li>🚧 8:00am to 1:00pm on Saturdays.</li> <li>🚧 No time on Sundays or public holidays.</li> </ul> </li> <li>ii. Entry of heavy machineries or vehicles and delivery timings on work site will be adjusted such that vehicles do not queue up at other routes.</li> <li>iii. Temporarily stop work or access in work zone during school and office hours between 8:30am to 9:30am and 2:00pm from Mondays to Fridays.</li> </ul>	<p>Construction Phase</p> <p>Construction Phase</p> <p>Construction Phase</p>	<p>Contractor</p> <p>Contractor</p> <p>Contractor</p>
<b>Foremen / Signaling</b>	<ul style="list-style-type: none"> <li>i. Special foremen will be employed to control vehicular movement in and outside the work zone.</li> <li>ii. Foremen will wear appropriate PPEs and use TCDs to guarantee efficient work zone management.</li> <li>iii. Two-way radios and color flags will be provided to all foremen.</li> </ul>	<p>Construction Phase</p> <p>Construction Phase</p>	<p>Contractor</p> <p>Contractor/Project Developer</p>

## Mandatory Sign



## Warning Signs





**ANNEXURE-VI**

**Air Dispersion Modeling**

# AIR DISPERSION MODELING REPORT

## Overview

As discussed earlier in chapter two of this ESIA report the proposed project mainly includes installation of 02 X 450 R-LNG sets of F class combined-cycle power generation units namely unit 7 & 8 inside the boundary of BQPS-I which will replace existing HFO based unit 3 and 4, it is expected that during the operational phase 02 X 450 R-LNG sets of F class combined-cycle power generation units may result in gaseous emissions, therefore a comprehensive and detailed Air Dispersion Modeling Study was conducted by using “AERMOD” (American Meteorological Society/Environmental Protection Agency Regulatory Model).

Aims and objectives of this modelling study are further elaborated as follows:

- To predict the emission levels, concentrations and determine if the predicted emission levels from the operations of newly proposed 02 X 450 R-LNG Based Power Generation Units exceeds the applicable Sindh Environmental Quality Standards as defined by Sindh Environmental Protection Agency.
- To compare emission levels of newly proposed 02 x 450 MW R-LNG Based Power Generation Units by previously used HFO and NG Based Power Generation Units; by considering two different scenarios namely Scenario-I : Emission from newly proposed power generation units and Scenario-II: Emissions from previously used HFO and NG Based Power Generation Units.

## AERMODE Working Principle

The United States Environmental Protection Agency approved regulatory air quality model AERMOD1 was used to simulate emissions from the proposed project. AERMOD is a steady state regulatory air dispersion plume model developed by USEPA. The data information flow is shown in **Figure 1**

The AERMOD modeling system consists of two pre-processors including:

- AERMET-meteorological preprocessor
- AERMAP for characterizing the terrain and generates receptor grids for the dispersion model.

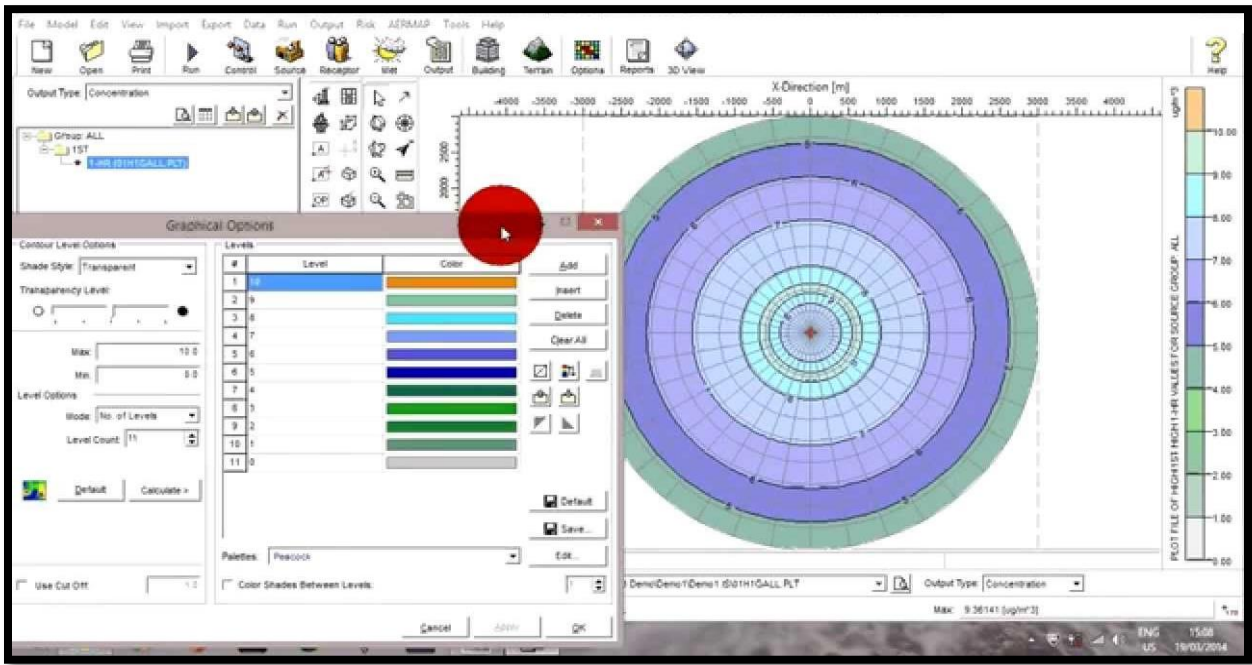


Figure 1: An Overview of AERMOD Modeling Tool<sup>1</sup>

Moreover it is important to note that the air dispersion contour generated by AERMOD represents the predicted concentration of pollutants which is estimated by Gaussian Dispersion Modeling equation as given below;

$$C(x, y, z) = \frac{Q}{2\pi u \sigma_y \sigma_z} \exp\left\{-\frac{1}{2}\left(\frac{y}{\sigma_y}\right)^2\right\} \left( \exp\left\{-\frac{1}{2}\left(\frac{z-H}{\sigma_z}\right)^2\right\} + \exp\left\{-\frac{1}{2}\left(\frac{z+H}{\sigma_z}\right)^2\right\} \right)$$

Where,

- Q = Emission rate
- $\sigma_x$  &  $\sigma_y$  = Dispersion coefficients for horizontal & vertical velocity components
- H = Effective stack height
- C = Estimated concentration of pollutants

<sup>1</sup> [https://www.weblakes.com/products/aermod/resources/lakes\\_aermod\\_view\\_release\\_notes.pdf](https://www.weblakes.com/products/aermod/resources/lakes_aermod_view_release_notes.pdf)

Now,  $\sigma_x$  &  $\sigma_y$  are affected by vertical mixing in the atmosphere and atmospheric stability conditions like adiabatic, normal etc. which further determine the inversion and temperature laps rates which are again estimated by two type of met data file including;

- Surface Meteorological file which contains following data;
  - Surface wind direction
  - Wind speed
  - Dew point
  - Wind class
  - Other condition etc.
  
- Upper Air Met data file which contains following data:
  - Atmospheric pressure
  - Temperature
  - Speed and direction variation with height

*\*Normally upper wind data file contains data up to 20 km height in air.*

#### **Emission Source Geometrical Data**

The pattern of plot depends on a number of source geometrical (stack dia & stack height in case of point stationery source). In other words, if stack height is changed, the pattern of plot may entirely differ which indicates that if model predict the plot geometry in some certain direction like SW, it may change to NE if there is a direction in any hour of the a particular day as the concentrations are calculated on hourly basis within in a given gridding pattern around the source.

#### **Meteorological parameters**

Following are the major met parameters which effect the dispersion of a pollutant;

- Wind Direction, Speed, atmospheric stability class, sky condition on surface (Surface Meteorological data file obtained by Automated Weather Station on ground)
- Atmospheric Pressure, wind Directions, Speed at different height from the ground level (Upper Air Sounding Meteorological Data file obtained through Balloon Sounding Flight)

The software utilizes hourly surface met data file and upper air profile met data files and it calculates hourly concentrations (using Gaussian Modeling Equation) at each Grid location around the source within selected grid domain while considering different options for example first highest concentration, second highest concentration and so on at each grid.



Usually the highest values are predicted mainly due to low surface wind speed at particular grid location in particular wind direction at particular hourly of the day of the year which may differ from wind direction in windrose plot. Therefore the model plot contours all around the source which indicates that the model predict concentrations on hourly met data basis instead of averaged dominant wind pattern of the day or month or year. Once the preprocessing works are done the user may plot any of the selected rank of highest concentration. Each of the selected highest values exhibit different pattern of plot which may entirely differ from each other for example the first highest concentration plot may represent pattern in certain direction while the second highest concentration plot may represent other direction.

## Emission Sources

- 02 Stacks of newly proposed 02 X 450 R-LNG Based Combined Cycle Power Generation Units.
- 02 Stacks of existing HFO and NG Based Power Generation Units.

*Note\**

*02 Stacks of existing HFO and NG Based Power Generation Units are considered as emission source just for the sake of comparative analysis between newly proposed power generation units and existing ones. Once newly proposed power generation units are operational existing HFO and NG based power generation units will be no longer.*

## Modeling Scenarios

To compare emission levels of newly proposed 02 x 450 MW R-LNG Based Power Generation Units by previously used HFO and NG Based Power Generation Units two different scenarios were considered for modeling namely;

- **Scenario-I:** Emission from newly proposed power generation units
- **Scenario-II:** Emissions from existing HFO and NG Based Power Generation Units.

## Modeling Input data and Assumptions

Following are model inputs in each scenario;

- Universal Transverse Mercator (UTM) as projection for zone class of 42 in datum of World Geodetic System 1984 (WGS 84) was used to define the modeling domain
- Hourly surface meteorological data of 2016 was used along with NOAA/ESRL Radiosonde Upper Air Profiling data. These datasets were pre-processed using AERMET (a data pre-processing tool) to generate AERMOD ready files of (i) surface file and (ii) profile file
- Output emissions concentrations are modeled for 24-hrs and annual averaged period for NO<sub>x</sub>, while for 8-hrly averaged for CO and compared with SEQS for compliance status of the emissions

- About 180 Uniform Polar Receptors are plotted with maximum radius of 5 km around the plant by assuming flat and elevated terrain with 10 degree incremental as shown in **Figure 2**.
- The model output was selected as 1st Highest Ranke values are plotted in form of counters in selected modeling domain
- The final background concentration<sup>2</sup> for NO<sub>x</sub>, CO and SO<sub>2</sub> was used as 28.8 µg/m<sup>3</sup>, 2.30 mg/m<sup>3</sup>, 19.3 ug/m<sup>3</sup> in the present study.
- The emission rates for each of pollutants data based upon the plant design data for proposed plant and existing units of BQPS-I are given **Table-1**.

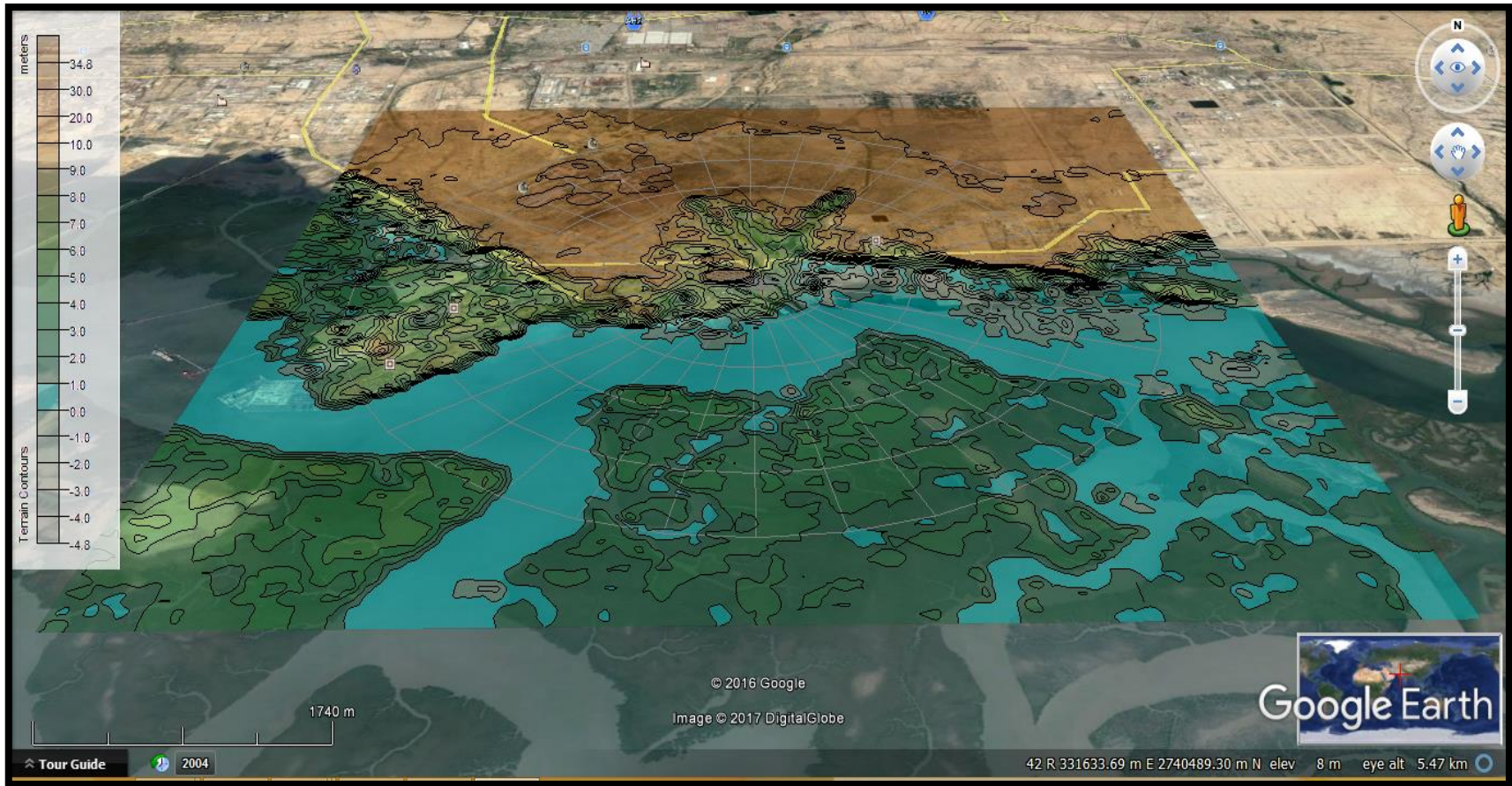
**Table 1: Model Input Data**

Parameters	Units	Input Values			
		Proposed		Exiting	
		Stack-I	Stack-II	Unit-3	Unit-4
<b>Design Parameters</b>					
<b>Stack Dia</b>	m	7.3	7.3	4.15	4.15
<b>Stack Height</b>	m	45	45	100	100
<b>Exit Velocity</b>	m/s	20	20	19.75	19.75
<b>Exit Temperature</b>	Degree C	97	97	160	160
<b>Emission Rates</b>					
<b>NO<sub>x</sub></b>	g/s	27.3	27.3	114.81	115.45
<b>CO</b>	g/s	1.9	1.9	25.51	27.01
<b>SO<sub>2</sub></b>	g/s	NIL	NIL	361.12	389.96

<sup>2</sup>EIA study report of Engro Powergen Limited 450 MW RLNG CCPP Port Qasim Authority, Karachi, 2015.

## **Meteorological data for modeling**

The hourly surface meteorological data of Karachi for 2016 is used in the modeling. The data analysis was carried out using Breeze MetView software and Windrose plots were generated showing dominant wind direction and wind speed on monthly basis as well as on annual basis. This data analysis indicates that the prevailing dominant wind is blowing from W-SW direction on annual basis as shown in Figure-3 while monthly wind plot shows that predominant wind is blowing from NW in Jan, from West in Feb to May, from East in Jun, from SW in Jul to Oct and NE in Nov to Dec as shown in **Figure-4**.



**Figure 2. Uniform Polar Receptors Grid with Maximum Radius of 5 km and Terrain Image of the Study Area**

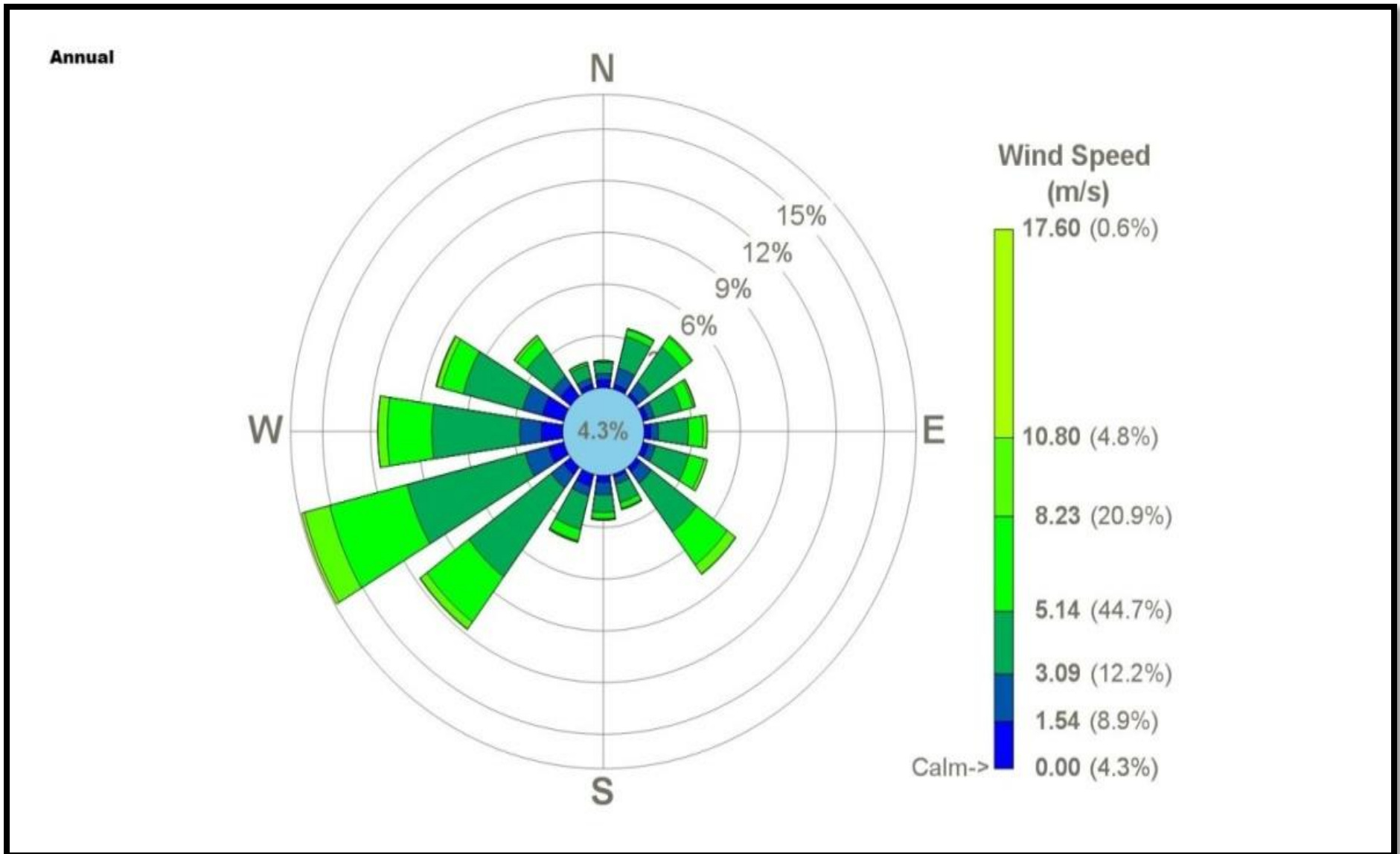


Figure 3. Windrose Plot Showing Dominant Annual Direction during 2016

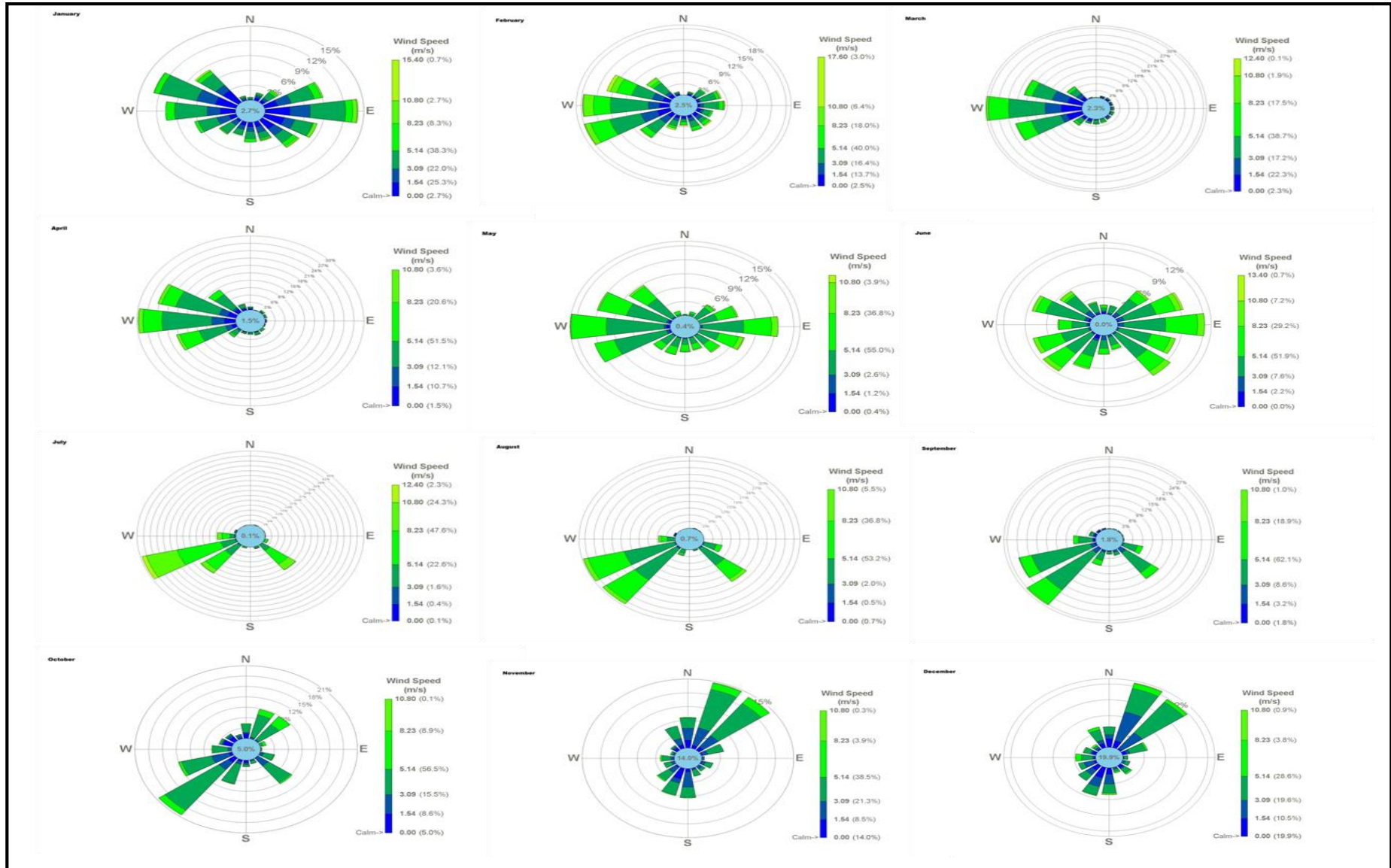


Figure 4. Windrose Plot Showing Dominant Monthly Direction during 2016

## Model Output Data

The maximum incremental concentration levels in ambient air for CO and NO<sub>x</sub> were simulated for 24-hour and annual averaging period whereas CO was modeled for 1-hour and 8-hour averaging period. As given in Table 2 & 3, in terms of the increment in pollutant concentrations at the ground-level near the project-site for Scenario 1 which represent the normal operation of plant on R-LNG. In this scenario, the plant will operate on the combined cycle mode with the exhaust emissions being emitted from the HRSG stack only.

The emissions from the HRSG stack will have a lower temperature compared to emissions from the bypass stack. Due to the lower temperature, exhaust from the HRSG stack will encounter less dispersion in the air resulting in greater incremental concentrations at the ground-level close to the Project site. However, these incremental concentrations of CO and NO<sub>x</sub> in Scenario 1 are still in compliance with the SEQS.

The contours for incremental concentrations of pollutants from the proposed Project for Scenario 1 and Scenario 2 are presented in **Figures 5 to 12**. **Figures 13 and 14** indicate the level of SO<sub>2</sub> concentration reduction from existing Units-3 and Unit-4 of the BQPS-I which has to be replaced by the proposed project.

The model predicts that about **8.704 ug/m<sup>3</sup>** is the expected reduction in emission of NO<sub>x</sub> due to abandoning of the existing unit-3 & unit-4 when replaced by the R-LNG based power generation units for 24-hrly averaged predicted simulation.

Similarly, the model results depict that the potential reduction in CO emissions are about **4.79 ug/m<sup>3</sup>** for 8 hrs averaged levels.

**Table 2: Incremental (Mini, Max, & Avrg) NO<sub>x</sub> Emission Concentrations (ug/m<sup>3</sup>)**

Measurements	Scenario-I		Scenario-II	
	24-Hrly	Annual	24-Hrly	Annual
Min. Conc	0.35	0.49	1.8	0.3
Max. Conc	8.46	2.69	35.0	11.16
Avrg. Conc	2.276	0.398	10.98	1.97

**Table 3: Incremental (Mini, Max, & Avrg) CO Emission Concentrations (ug/m<sup>3</sup>)**

Measurements	Scenario-I		Scenario-II	
	1-Hrly	8-Hrly	1-Hrly	8-Hrly
Min. Conc	0.2	0.049	0.003	0.8
Max. Conc	3.50	0.941	29.12	13.5
Avrg. Conc (mg/m <sup>3</sup> )	0.003	0.00082	0.025	0.012

**Table 4: Incremental (Mini, Max, & Avrg) SO<sub>2</sub> Emission Concentrations**

Measurements	Scenario-I		Scenario-II	
	1-Hrly	8-Hrly	24-Hrly	Annual
Min. Conc	NIL	NIL	6	0.9
Max. Conc	NIL	NIL	114	37.8
Avrg. Conc	NIL	NIL	35.81	6.44

The data for scenario-II, is presented in table 3-5. Since the newly proposed power R-LNG based power generation units are designed to run on R-LNG instead of HFO therefore SO<sub>2</sub> emissions are not expected from the proposed project and it will result in significant reduction of about 35.81 ug/m<sup>3</sup> and 6.44 ug/m<sup>3</sup> of SO<sub>2</sub> by abandonment of existing HFO based power generation units, which indicates that there would be positive impact on the air quality by the proposed project.

### **Resultant Impact on Ambient Air Quality in the Study Area with the Project in Operation**

The incremental concentration of CO and NO<sub>x</sub> obtained from Scenario-I of the modeling exercise was added to the background concentration to determine the resultant CO and NO<sub>x</sub> concentration in the Study Area. The results after addition of background concentration are presented in **Table 4**. The results are then compared with the applicable standards. The results of the air dispersion modeling indicate that concentration of NO<sub>x</sub> in the air (31.076 ug/m<sup>3</sup>) when the plant is in operation will be compliant with the SEQS guidelines.



**Table 5: Predicted Ambient Concentration of Emissions from Proposed LNG based Power Plant**

Pollutants	units	Arg. Time	Incremental Concentration from proposed project	Background Conc.	Predicted ambient Conc. from proposed project	SEQS
NOX	Ug/m <sup>3</sup>	24-hrs	2.276	28.8	31.076	120
	Ug/m <sup>3</sup>	annual	0.398	-	-	80
CO	mg/m <sup>3</sup>	1-hrs	0.003	-	-	10
	mg/m <sup>3</sup>	8-hrs	0.00082	2.30	2.30082	5

**Conclusion:**

The model predicted that there would be a significant reduction in emissions due to replacement of existing HFO based power generation units by newly proposed 2 X 450 MW R-LNG based power generation units moreover the proposed power plant in operational phase will comply with the SEQs permissible limits of the ambient air quality.

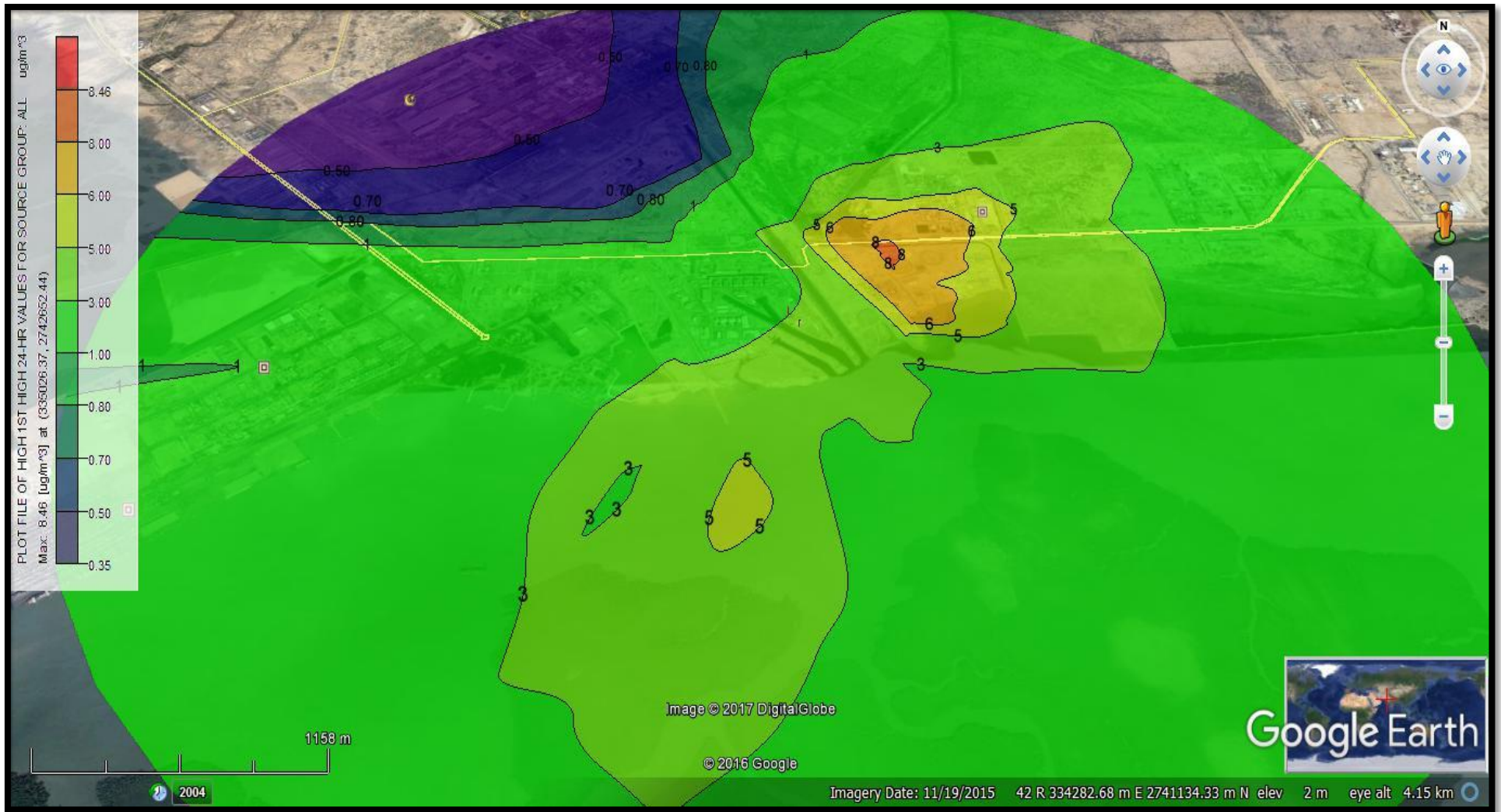


Figure 5: Spatial Dispersion of 1<sup>st</sup> Highest Concentrations of NOx for 24-Hrly Averaged for Scenario-I

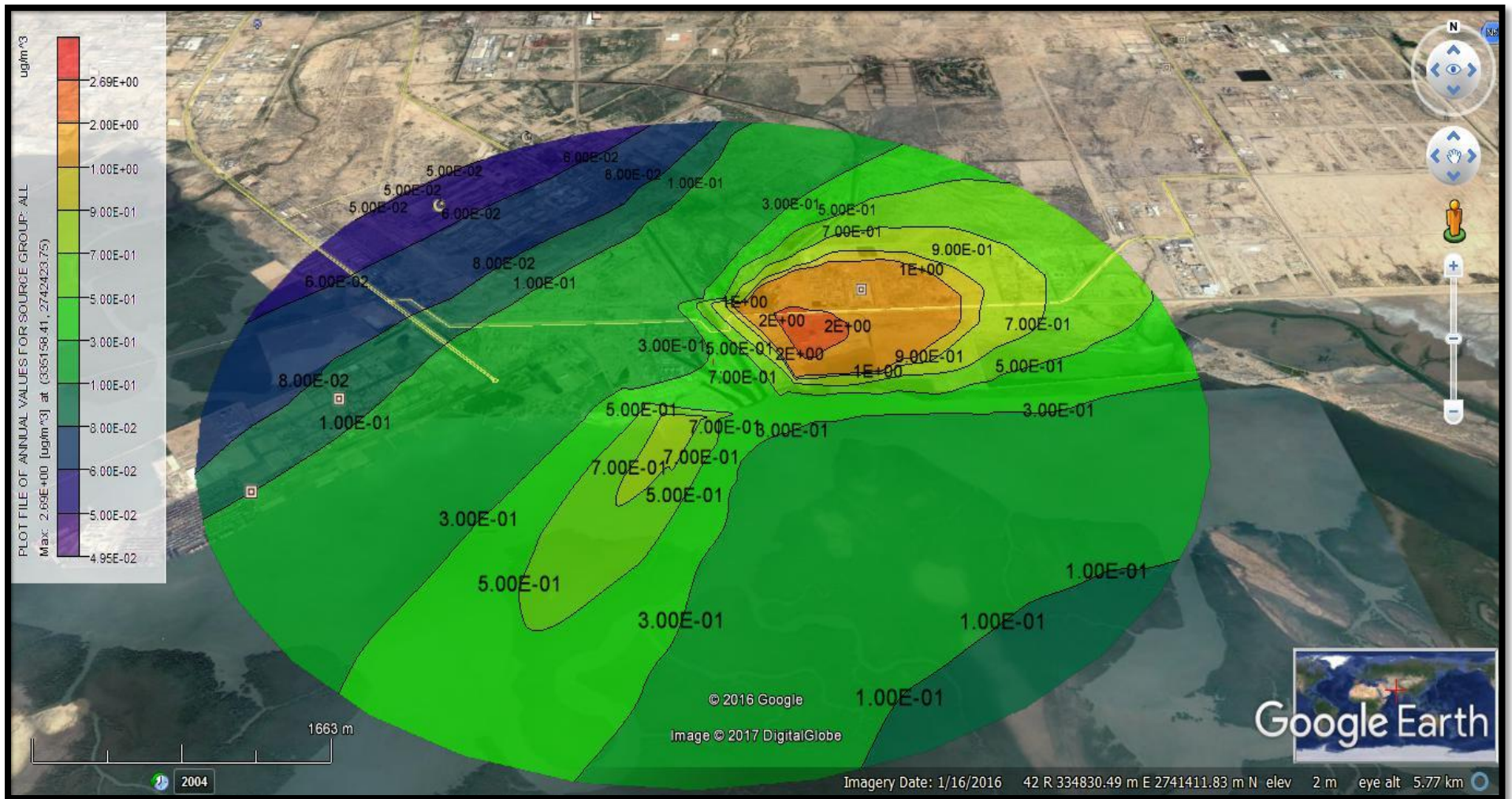


Figure 6: Spatial Dispersion of 1<sup>st</sup> Highest Concentrations of NO<sub>x</sub> for Annual Averaged for Scenario-I

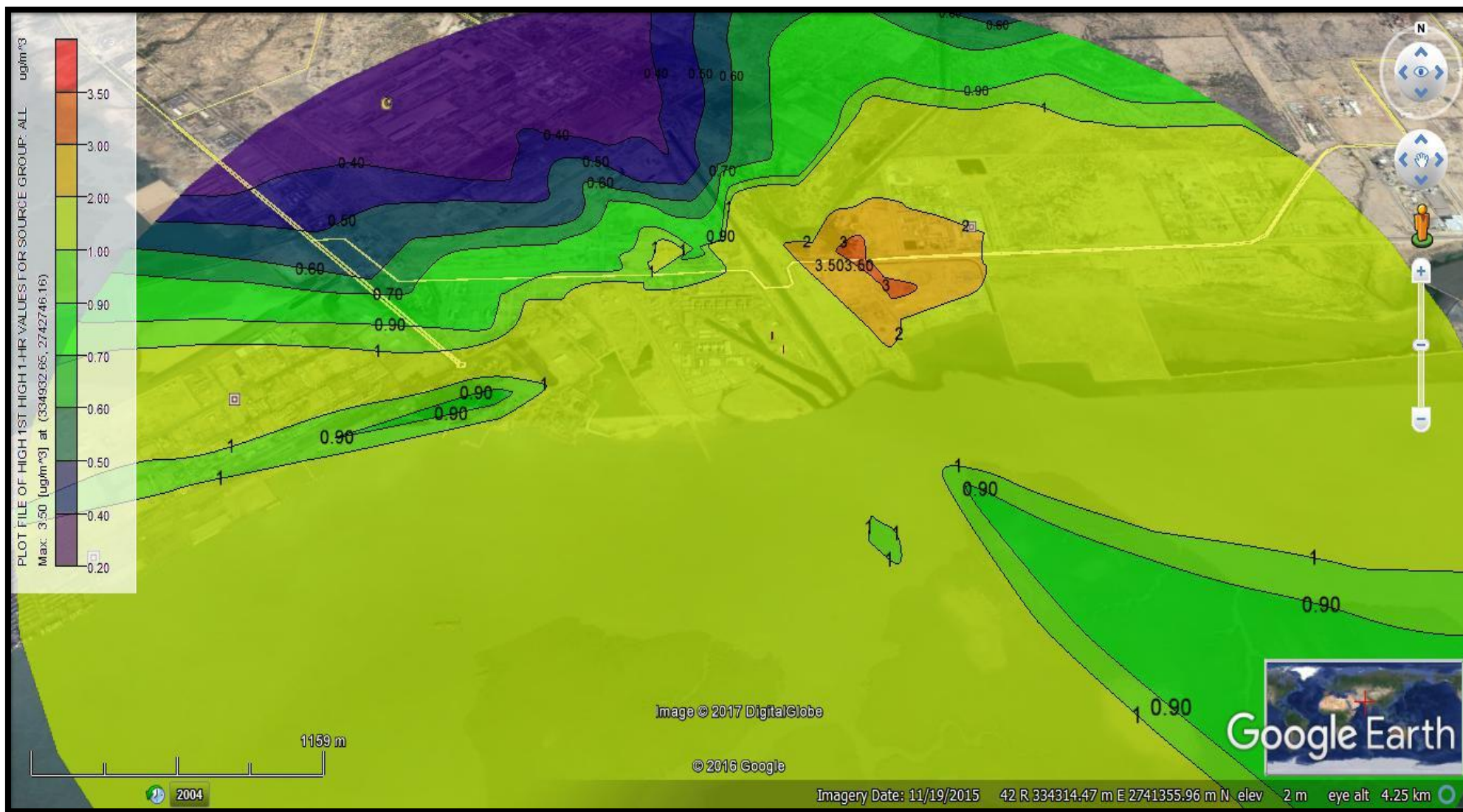


Figure 7: Spatial Dispersion of 1<sup>st</sup> Highest Concentrations of CO for 1-hrly Averaged for Scenario-I

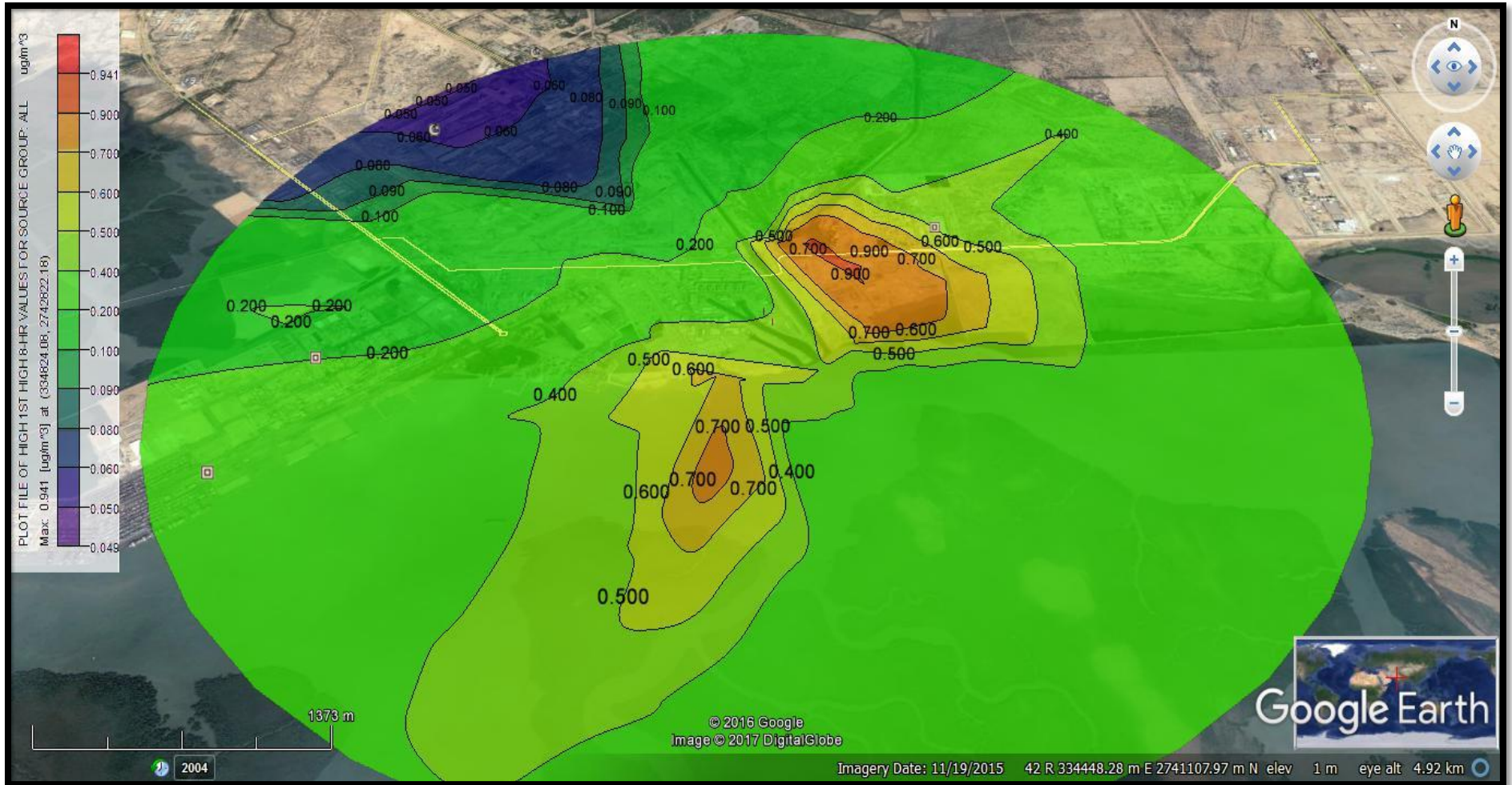


Figure 8: Spatial Dispersion of 1<sup>st</sup> Highest Concentrations of CO for 8-hrly Averaged for Scenario-I

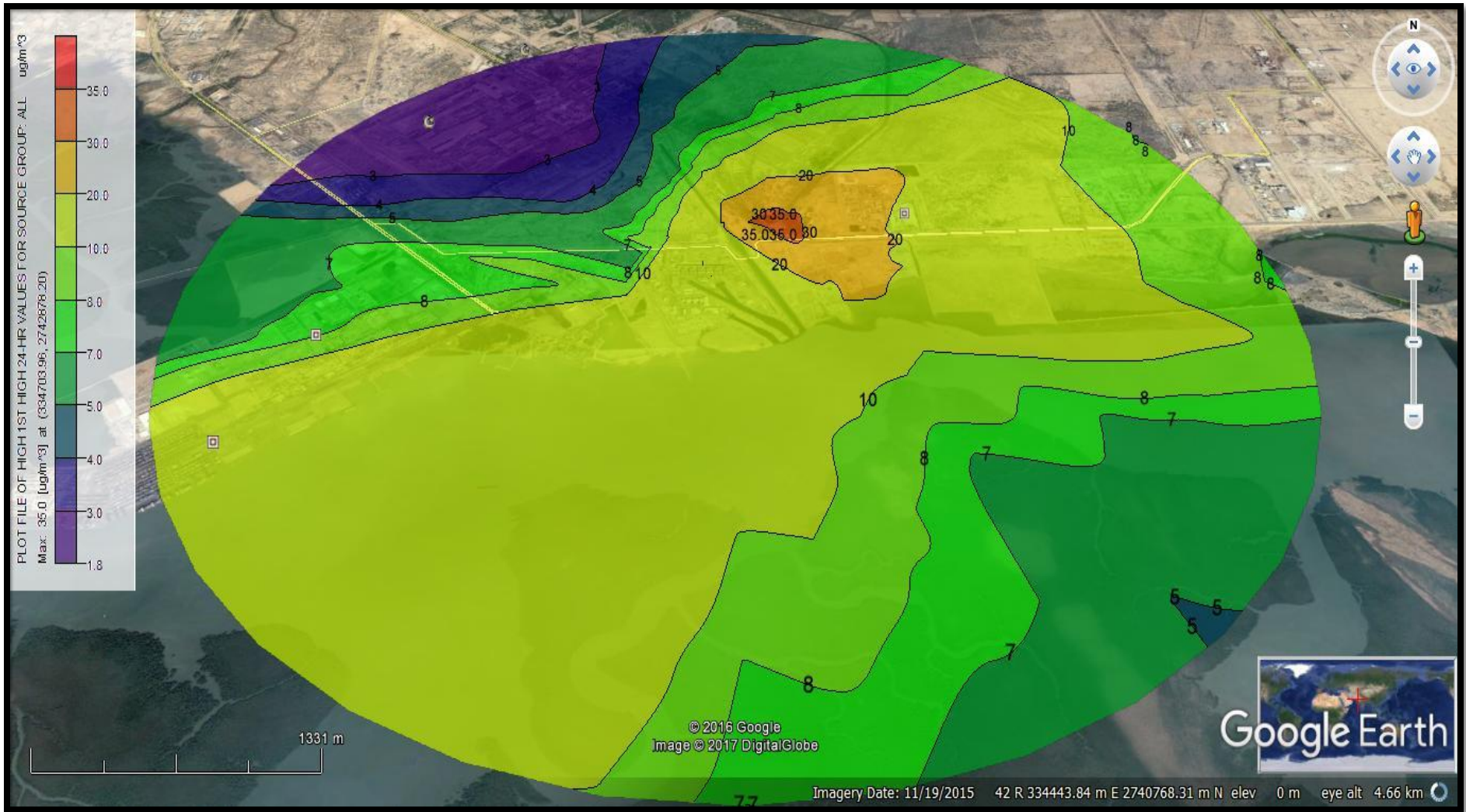


Figure 9: Spatial Dispersion of 1<sup>st</sup> Highest Concentrations of NO<sub>x</sub> for 24-hrly Averaged for Scenario-II

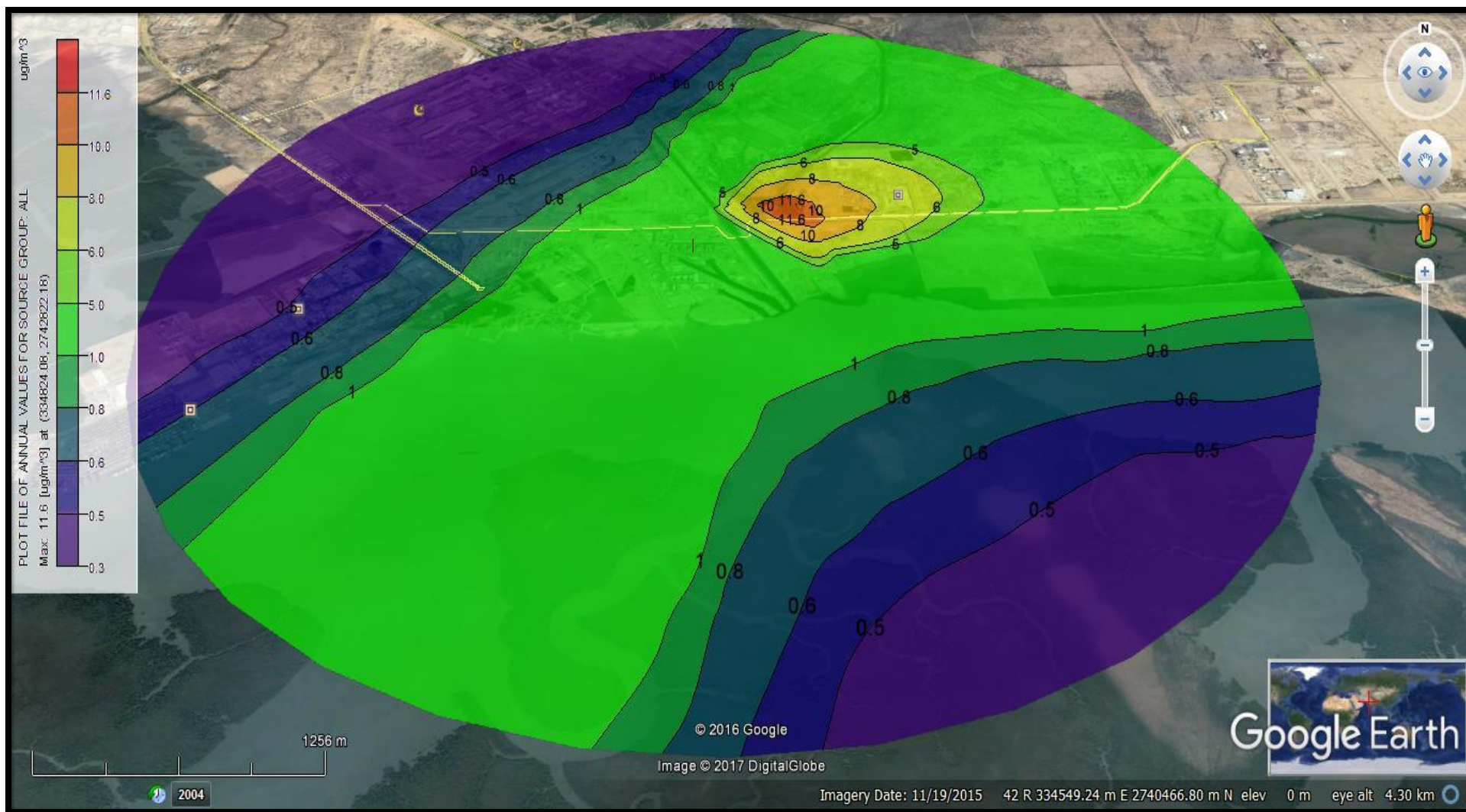


Figure 10: Spatial Dispersion of 1<sup>st</sup> Highest Concentrations of NO<sub>x</sub> for Annual Averaged for Scenario-II

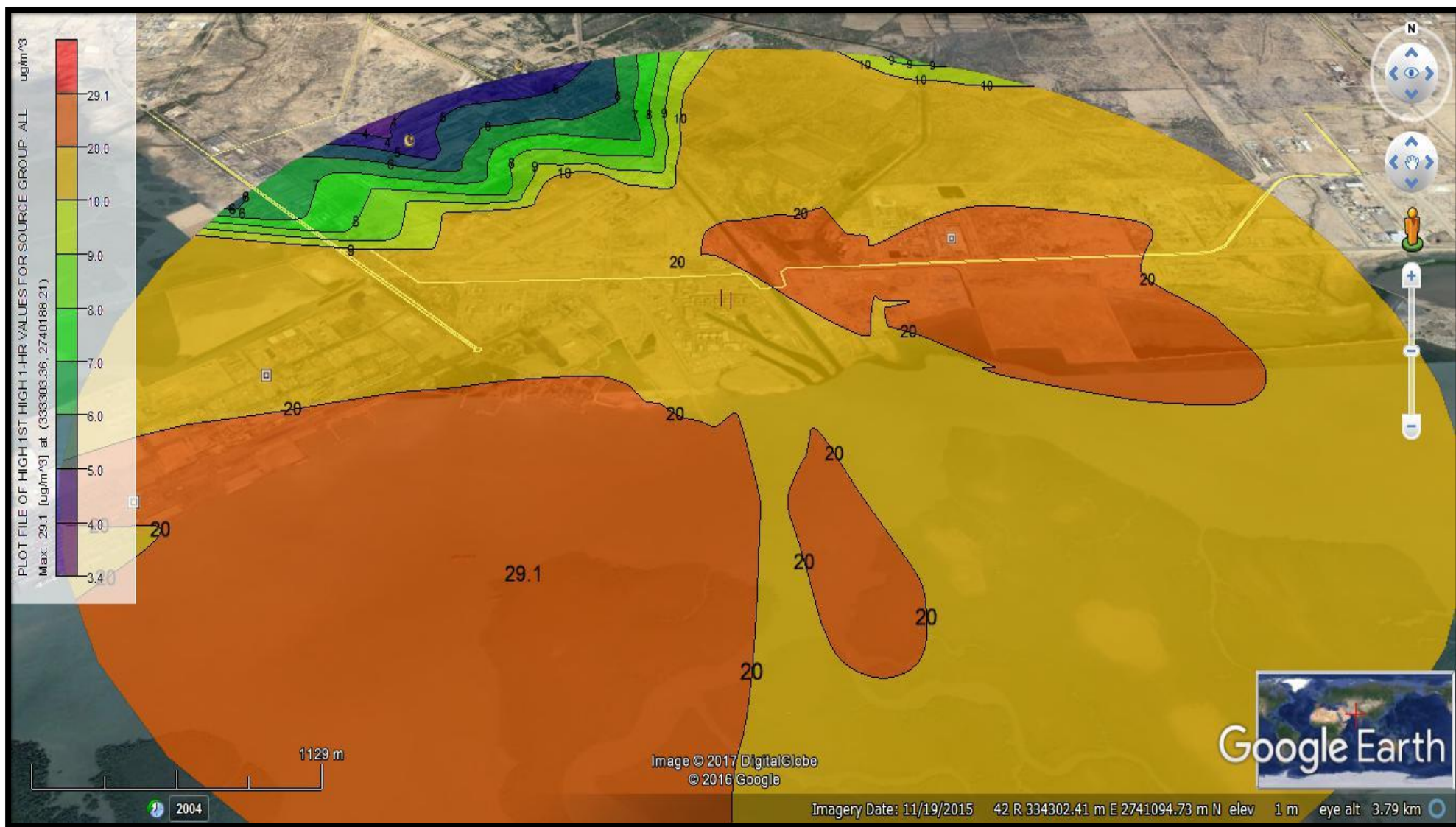


Figure 11: Spatial Dispersion of 1<sup>st</sup> Highest Concentrations of CO for 1-hrly Averaged for Scenario-II



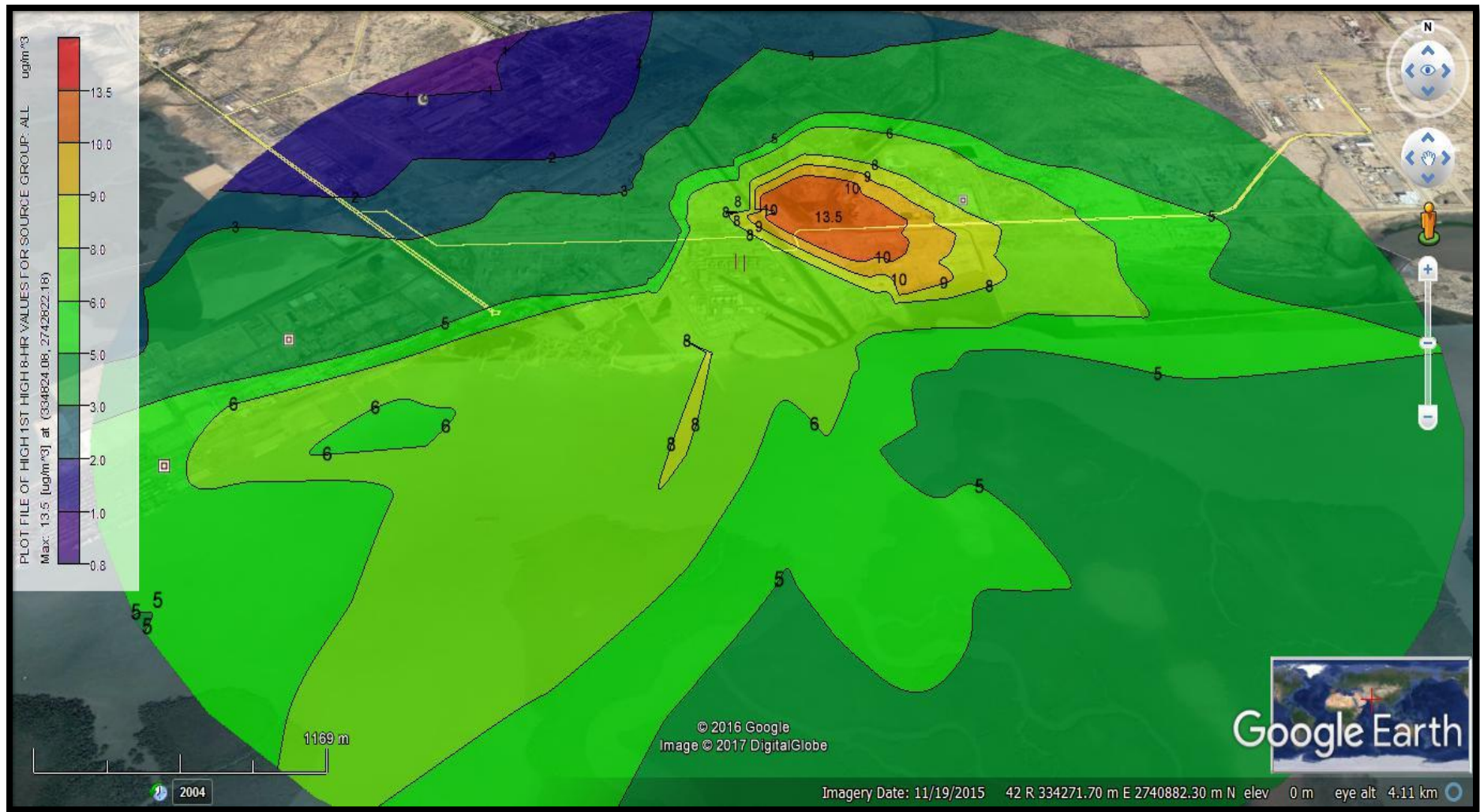


Figure 12: Spatial Dispersion of 1<sup>st</sup> Highest Concentrations of CO for 8-hrly Averaged for Scenario-II

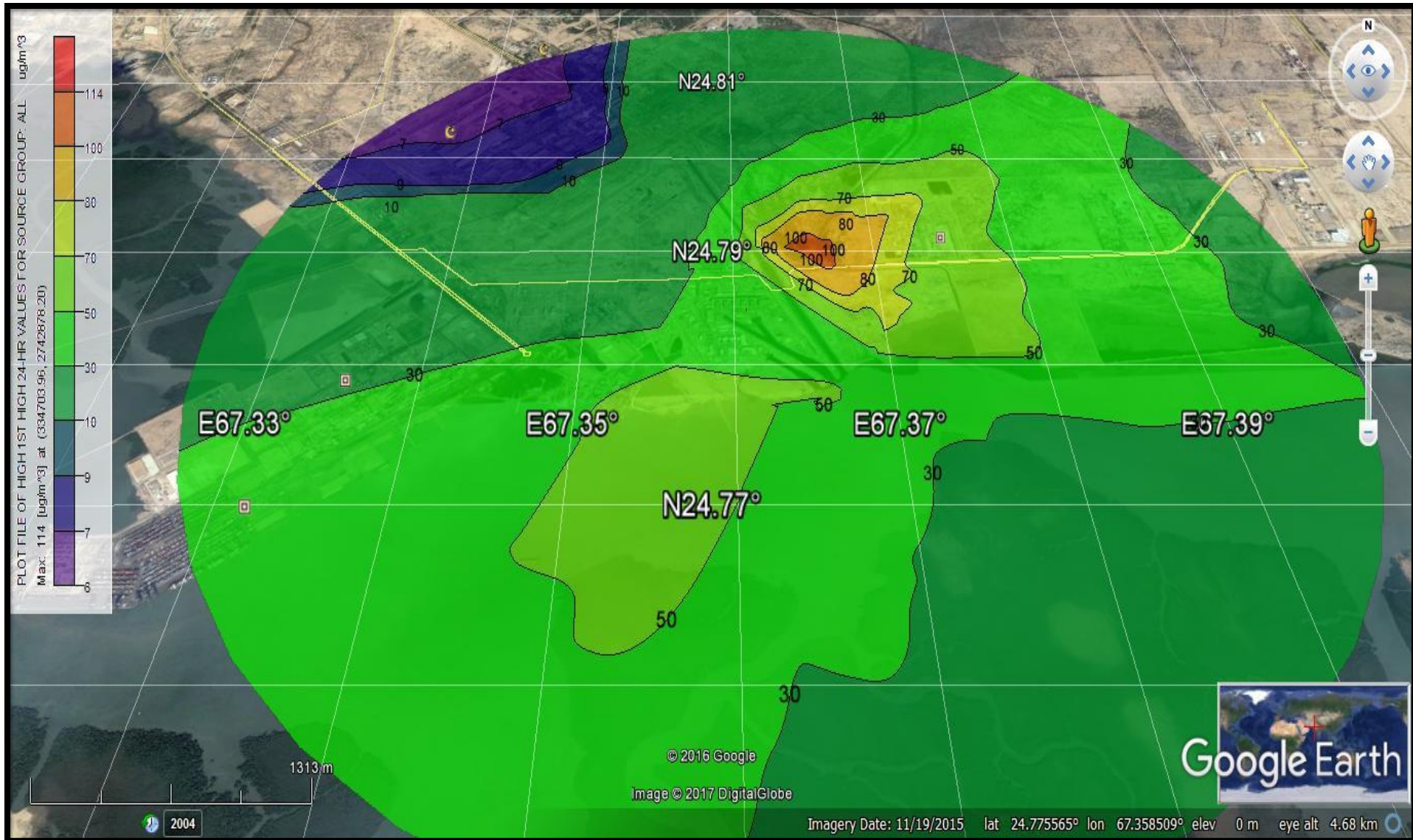


Figure 13: Spatial Dispersion of 1<sup>st</sup> Highest Concentrations of SO<sub>2</sub> for 24-hrly Averaged for Scenario

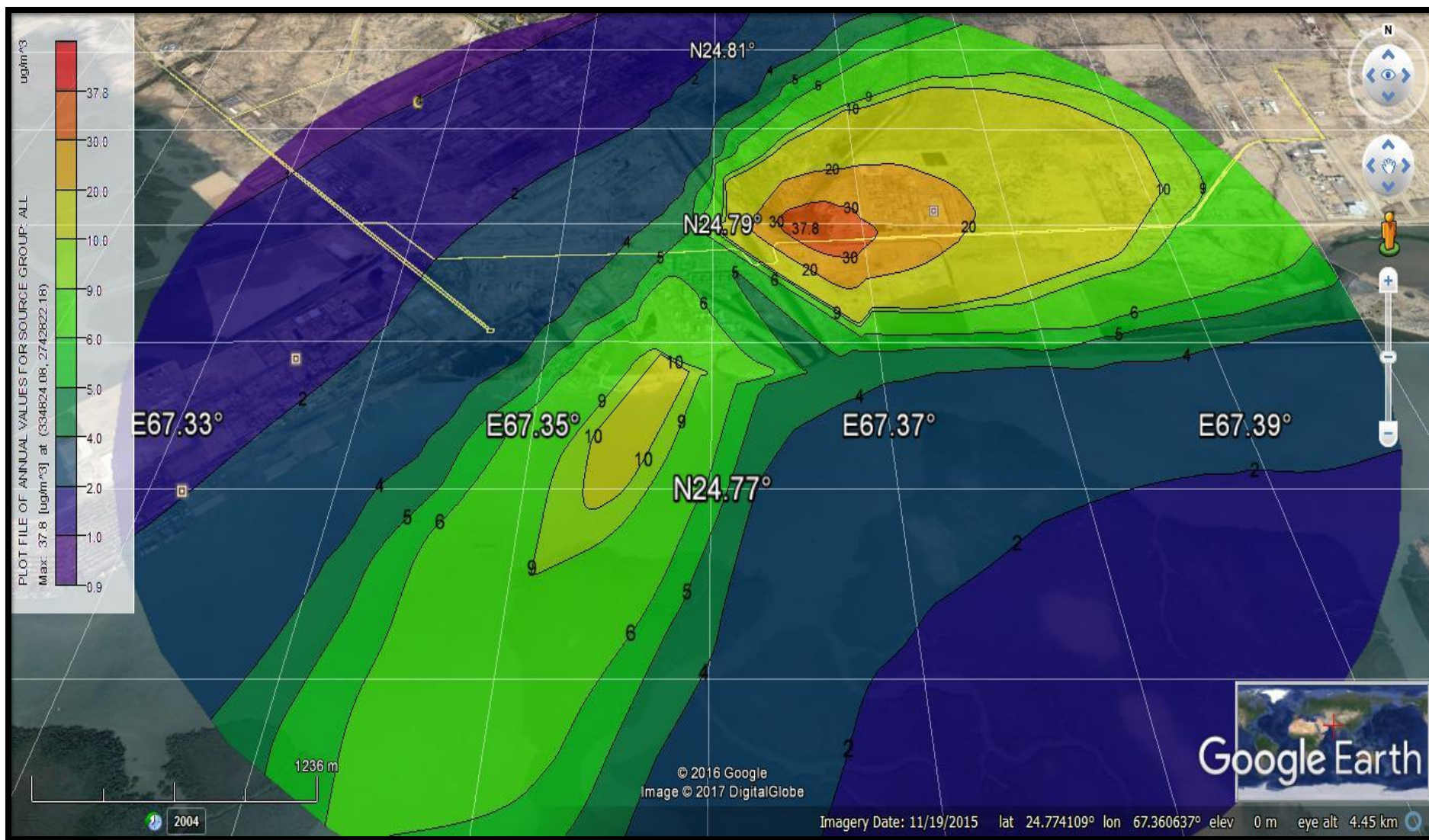


Figure 14: Spatial Dispersion of 1<sup>st</sup> Highest Concentrations of SO<sub>2</sub> for Annually Averaged for Scenario-II



## **ANNEXURE-VII**

Thermal Plume Modeling

# THERMAL PLUME MODELING REPORT

## Overview

Coastal areas are often used as a disposal environment for thermal effluents originating from the cooling processes in thermal or nuclear power plants. Studies providing information on thermal effluent behavior in receiving environments can contribute to efficiently manage such discharges, mitigating impacts on relevant environmental and economic values (Abbaspour et al., 2005)<sup>1</sup>. The changes caused by the effluents of power plants on ambient water temperature and, consequently, their impact on the aquatic biota has been studied for decades (e.g., Takesue & Tsuruta, 1978; Kelso & Milburn, 1979; Hester & Doyle, 2011; Coulter et al., 2014)<sup>2,3,4,5</sup>. The coastal development and associated pollution can potentially alter or damage important shore habitats nearby, disrupt vital ecological pathways and cause permanent loss of nursery grounds for commercial shellfish and fish species. Without good planning and careful consideration for existing coastal features, hydrodynamics and offshore bathymetric conditions, the consequences of such development can be severe and long lasting.

As discussed earlier in chapter two of this ESIA report the proposed project mainly includes installation of 02 X 450 R-LNG sets of F class combined-cycle power generation units namely unit 7 & 8 inside the boundary of BQPS-I which will replace existing HFO based unit 3 and 4, it is expected that during the operational phase 02 X 450 R-LNG sets of F class combined-cycle power generation units may use seawater for cooling purposes later on the heated effluent will be discharged into the receiving water body. Therefore a detailed and comprehensive thermal plume modeling was conducted for the proposed project by using USEPA-supported mixing zone model, CORMIX 9.0 of MixZone Inc.

- 
- <sup>1</sup> Abbaspour, M.; Javid, A.H.; Moghimi, P.; Kayhan, K. (2005) - Modelling of thermal pollution in coastal area and its economic and environmental assessment. *International Journal of Environmental Science & Technology*, 2(1):13-26. DOI: 10.1007/BF03325853
  - <sup>2</sup> Takesue, K.; Tsuruta, A. (1978) - The thermal effects of cooling system of a thermal power plant on photosynthesis of marine phytoplankton. *Journal of the Oceanographical Society of Japan*, 34(6):295-302. DOI: 10.1007/bf02111177
  - <sup>3</sup> Kelso, J.R.M.; Milburn, G.S. (1979) - Entrainment and Impingement of Fish by Power Plants in the Great Lakes which use the Once-Through Cooling Process. *Journal of Great Lakes Research*, 5(2):182-194. DOI: 10.1016/S0380-1330(79)72145-9
  - <sup>4</sup> Hester, E.T.; Doyle, M.W. (2011) - Human Impacts to River Temperature and Their Effects on Biological Processes: A Quantitative Synthesis<sup>1</sup>. *Journal of the American Water Resources Association*, 47(3):571-587. DOI: 10.1111/j.1752-1688.2011.00525
  - <sup>5</sup> Coulter, D.P.; Sepúlveda, M.S.; Troy, C.D.; Höök, T.O. (2014) - Thermal habitat quality of aquatic organisms near power plant discharges: potential exacerbating effects of climate warming Fisheries. *Management and Ecology*, 21(3):196-210. DOI: 10.1111/fme.12064

Aims and objectives of this modelling study are further elaborated as follows:

- To quantify the impact area of proposed LNG based power unit on sea water conditions for an effluent at rate of 69, 622 m<sup>3</sup>/hr (with discharge velocity of 1.90 m/s).
- Determine the distance from the discharges point into sea at which the complete mixing of this effluent in the sea is achieved.
- Determine distance from the discharge point at which the SEQS limits of change in temperature of 3 degree C is achieved.
- To compare thermal plume levels of newly proposed 02 x 450 MW R-LNG Based Power Generation Units by previously used HFO and NG Based Power Generation Units; by considering two different scenarios namely Scenario-I: Cumulative Impact from Existing BQPS-I and Scenario-II: Cumulative Impact from Existing BQPS-I and BQPS-II by replacing 02 HFO based power generation units with newly proposed R-LNG based power generation units.

## **CORMIX Working Principle**

USEPA-supported mixing zone model, CORMIX 9.0 of MixZone Inc is a decision support system for environmental impact assessment of regulatory mixing zones resulting from continuous point source discharges. The system emphasizes the role of boundary interaction to predict steady-state mixing behavior and plume geometry. It is a comprehensive software system for the analysis, prediction of outfall mixing zones resulting from discharge. It contains mathematical models of point source discharge mixing within an intelligent computer-aided-design (CAD) interface. A snapshot of the CORMIX is shown in **Figure 1**.

## **Model Input Data and Modeling Scenarios**

The excessive discharged temperature of effluent measured in °C was assumed to be 32 °C however the ambient seawater temperature was taken as 25 °C hence representing the difference of about 7 °C. The effluent will be discharged into the channel having total surface area of about 37.5 m<sup>2</sup> for both the scenarios i.e. discharge from BQPS-I & BQPS-II referred to as Scenario-I and discharge from BQPS-I & BQPS-II (by replacing old HFO based power generation units with R-LNG based power generation units) The effluent will be discharged into sea water, where averaged depth of water body was measured as 12.5 m and it was also assumed that the depth of water where effluent is discharged is about 11 m. The other input data of Effluent Condition, Ambient Conditions and Discharge Geometry Condition are as given in Snapshot of **Figure 2**.

Scenario I and II are further defined as:

### **Scenario-I:**

Cumulative Impact from Existing BQPS-I and BQPS-II Discharges

**Scenario-II:**

Cumulative Impact from BQPS-I and BQPS-II (by replacing old HFO based power generation units with R-LNG based power generation units)

View of thermal discharge has been presented as **figure-3**

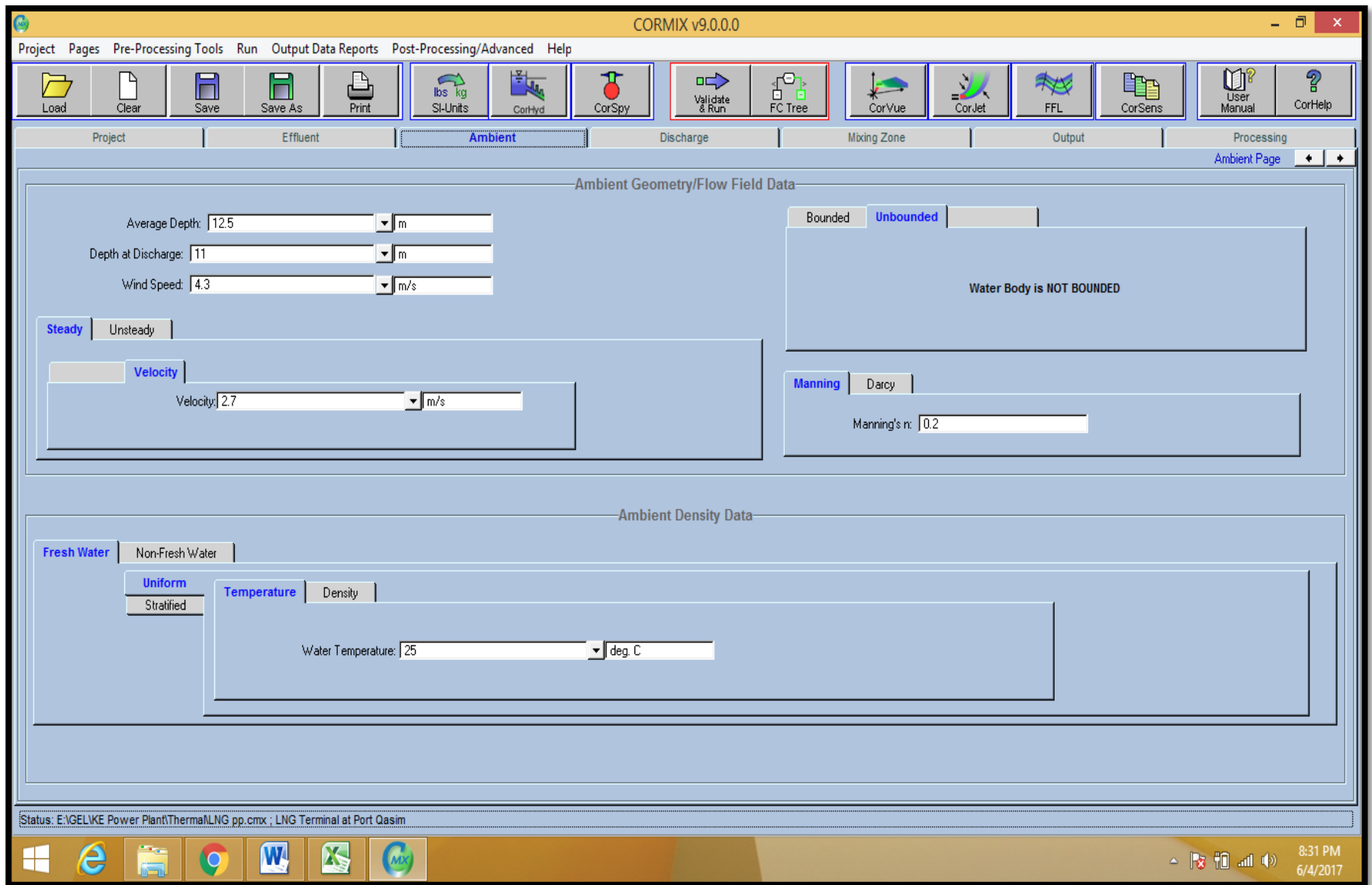


Figure 1: A Snapshot of COMIX9.0.0 Model used in present Study



```

*****
SUMMARY OF INPUT DATA:
-----
AMBIENT PARAMETERS:
Cross-section = unbounded
Average depth HA = 12.5 m
Depth at discharge HD = 11 m
Ambient velocity UA = 2.7 m/s
Darcy-Weisbach friction factor F = 1.3533
  Calculated from Manning's n = 0.2
Wind velocity UW = 4.3 m/s
Stratification Type STRCND = U
Surface temperature = 25 degC
Bottom temperature = 25 degC
Calculated FRESH-WATER DENSITY values:
Surface density RHOAS = 997.0456 kg/m^3
Bottom density RHOAB = 997.0456 kg/m^3
-----
DISCHARGE PARAMETERS: Single Port Discharge
Nearest bank = left
Distance to bank DISTB = 2000 m
Port diameter D0 = 25.2313 m
Port cross-sectional area A0 = 500.0000 m^2
Discharge velocity U0 = 0.14 m/s
Discharge flowrate Q0 = 71.25 m^3/s
Discharge port height H0 = 11 m
Vertical discharge angle THETA = -90 deg
Horizontal discharge angle SIGMA = 0 deg
Discharge temperature (freshwater) = 32 degC
Corresponding density RHO0 = 995.0253 kg/m^3
Density difference DRHO = 2.0203 kg/m^3
Buoyant acceleration GP0 = 0.0199 m/s^2
Discharge concentration C0 = 7 deg.C
Surface heat exchange coeff. KS = 0 m/s
Coefficient of decay KD = 0 /s

```

Figure 2: Snapshot of CORMIX input Data



Figure 3: View of Thermal Discharge Location of Proposed Power Project

### **Resultant Cumulative Impact of Thermal Discharge on Seawater from Proposed Project**

The model predicted that the ambient water quality standard (3 °C change in water body i.e. sea in present case) may encountered at 8.89 m from the discharge point-B within the RMZ in existing scenario-I. The Buoyancy assessment indicated that the effluent density is less than the surrounding ambient water density at the discharge level.

Therefore, the effluent is POSITIVELY BUOYANT and will tend to rise towards the surface. The benthic attachment analysis showed that for the present combination of discharge and ambient conditions, the discharge plume becomes attached to the channel bottom within the NFR immediately following the efflux and high benthic concentrations may occur. In comparison with scenario-II, the ambient water quality standard may encounter at the shorter distance of 8.86 m from the discharge point-B within the RMZ of 100m. In the Regulatory Mixing Zone, the RMZ specification occurs before the near-field mixing regime (NFR) has been completed as predicted in the model. The specification of the RMZ is highly restrictive. The variation of Discharge Temperature in Downstream is shown in **Figure 4** and trend of dilution in downstream after discharge is shown in **Figure 5**. The vertical green dotted line and trend dotted line in each of **Figure 4 & Figure 5** showed the Water Quality Standard of 3 degree C change in water body and Regulatory Mixing Zone of 100 m respectively. The 3-D view of the variation in temperature in thermal plume is shown in Figure 6 and view in Google Map is shown in **Figure 7**.

The model predicted that the when proposed project is operational and two existing units of BQPS-I would be replaced then there would be reduced discharge flow rate and velocity which would result in shorter distance downstream 8.86m within which ambient water quality standard (3 degree C change in water body i.e. sea in present case) may achieve within Regulatory Mixing Zone (100 m) limits provided the given conditions as input in simulation.

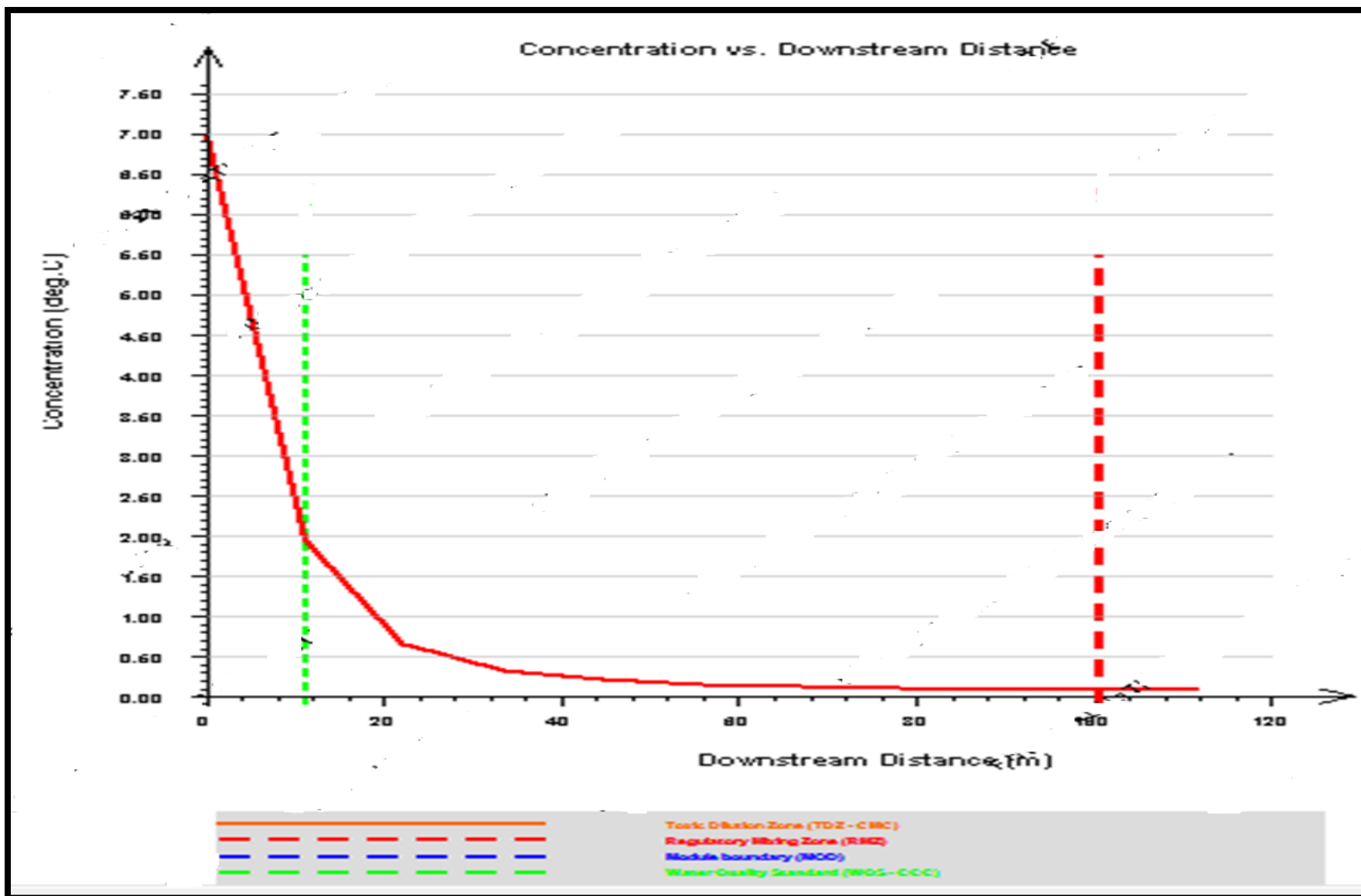


Figure 4. The variation of Discharge Temperature in Downstream.

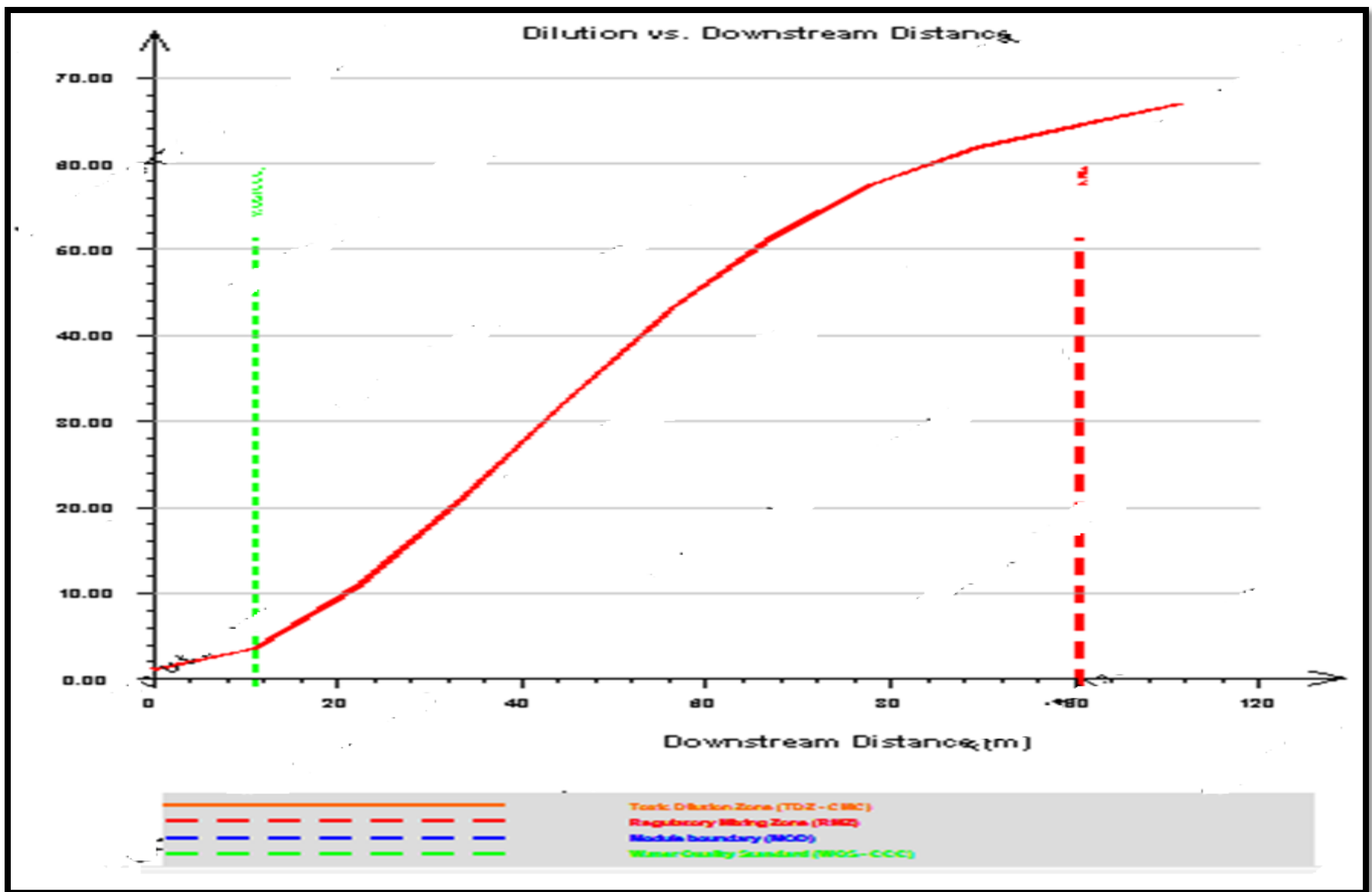


Figure 5. The variation of Dilution in Downstream

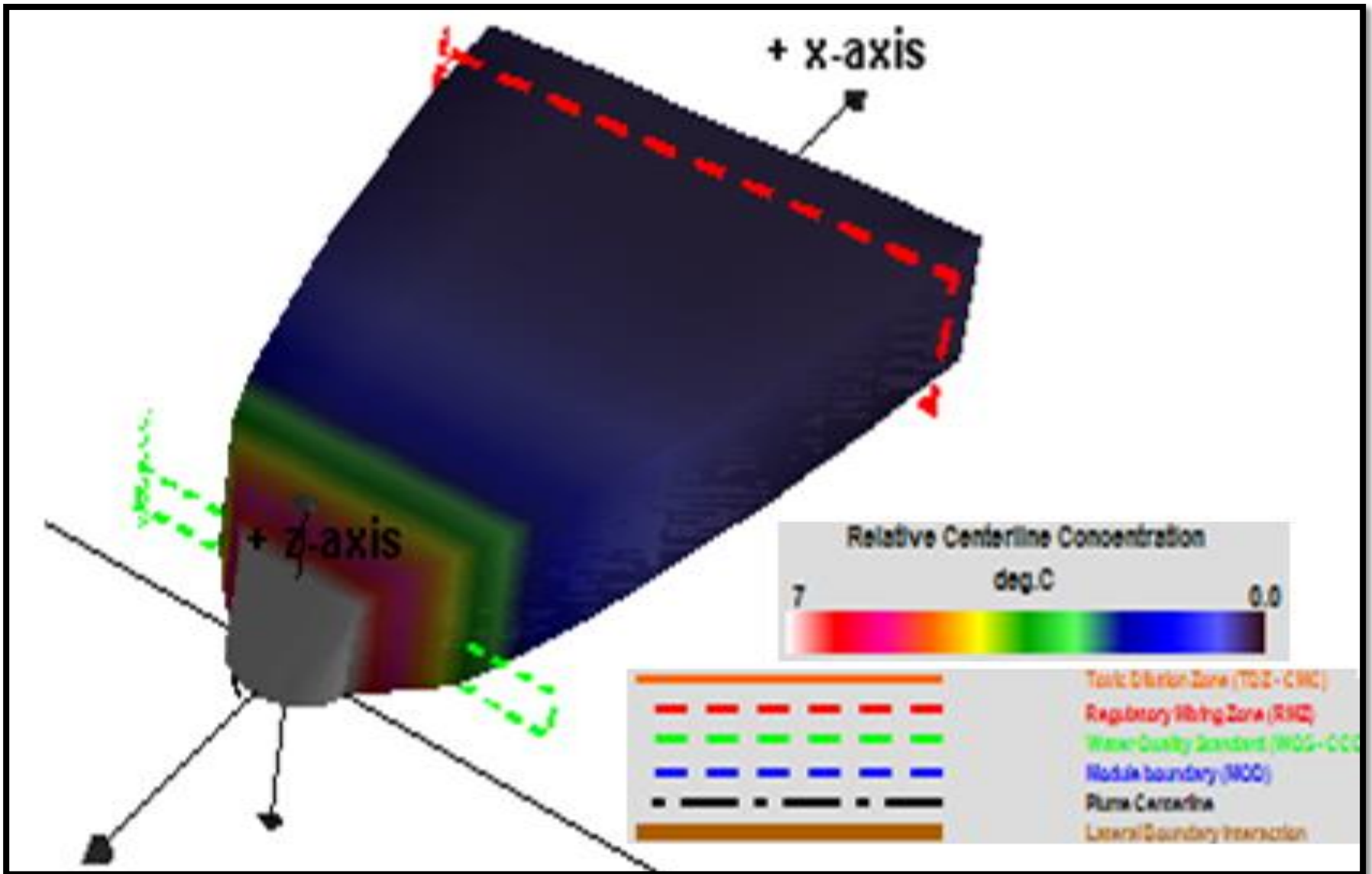


Figure 6. 3-D View of Temperature Variation in Downstream in RMZ

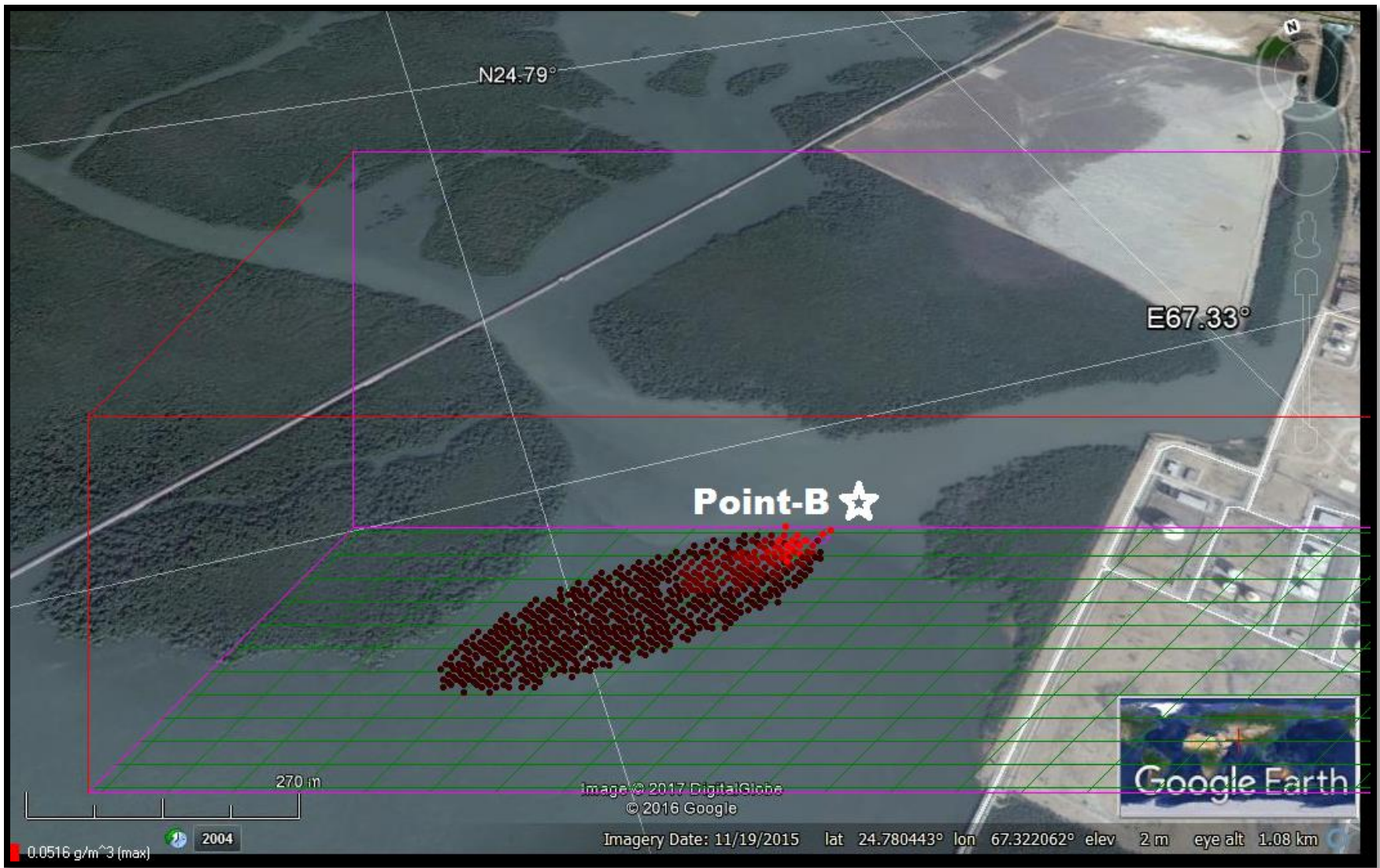


Figure 7: 3-D View of Outfall in Google Map of the Proposed Project



**ANNEXURE-VIII**

General Layout of the Proposed Project





**LIST OF EQUIPMENTS & BUILDING STRUCTURES**

NO.	DESCRIPTION	名称	REMARK
1	GAS TURBINE	燃机	
2	STEAM TURBINE HOUSE	汽机主厂房	
3	GT MAIN TRANSFORMERS	燃机主变	
4	UNIT AUXILIARY TRANSFORMERS	厂用变压器	
5	ST. MAIN TRANSFORMERS	汽机主变	
6	START-UP/STANDBY TRANSFORMER	起/备变	
7	H.R.S.G	余热锅炉	
8	STACK	烟筒	
9	GAS FORWARDING SKID	燃气前置模块	
10	UNITS DRAIN PIT	机由排水槽	
11	AIR COMPRESSOR HOUSE	空压机房	
12	DIESEL GENERATOR SET	柴油发电机	
13	FIRE FIGHTING PUMP HOUSE	消防泵房	
14	FIRE FIGHTING/SERVICE WATER PONDS	消防水池	
15	CHEMICAL WATER TREATMENT POND	化水车间	
16	WASTE WATER PONDS	废水池	
17	HYDROGEN GENERATOR STATION	制氢站	
18	WAREHOUSE AND WORKSHOP	材料库/检修车间	
19	CIRCULATE WATER PUMP HOUSE	循环水泵房	UTILISE USED EQUIPMENT
20	DOSING ROOM	加药间	
21	GAS CONDITION STATION	天然气调压站	
22	INTEGRATED PUMP HOUSE	综合泵房	
23	RELAY CABIN	继电室	
24	SUBSTATION	配电室	
25	ELECTRIC REACTOR	电抗器	
26	ADMINISTRATION BUILDING	行政办公楼	
27	GUARD HOUSE	警卫室	

0	2017.05.05	DES	设计	审核	批准		
版号	日期	状态	修改内容摘要	设计	审核	批准	
本图纸历史修改记录							
本文件的知识产权为华东电力设计院有限公司所有,任何单位和个人未经许可不得复制和使用,违者将依法追究。							
<b>华东电力设计院有限公司</b>		EPC总承包EPC-III 2x480MW		工程	设计	审核	
批准	设计	比例	1:1000	指绘及平面布置图			
审核	状态	日期	2017.05.05				
校核	日期	2017.05.05				版号	0
图号	附册1					版号	0

# LIST OF REFERENCES

---

Arthur J. Hanson et al, Pakistan's National Conservation Strategy Renewing Commitment to Action, Report of the Mid-Term Review, 2000

Environmental & Social Impact Assessment of 250 MW Dual Fuel Power Plant KPC-II Karachi Sindh

Environmental, Health, and Safety General Guidelines

faolex.fao.org, 2009

Hazardous Substances Rules, 2014;

[http://pqa.gov.pk/pqa\\_act.php](http://pqa.gov.pk/pqa_act.php)

<http://pqa.gov.pk/introduction.php>

[http://www.finance.gov.pk/survey/chapters\\_15/Highlights.pdf](http://www.finance.gov.pk/survey/chapters_15/Highlights.pdf)

[http://pqa.gov.pk/port\\_qasim\\_at\\_a\\_glance.php](http://pqa.gov.pk/port_qasim_at_a_glance.php)

<http://www.irispujab.gov.pk/Economic%20Surveys-New/Economic%20Survey%202015-16.pdf>

<http://blog.transcanada.com/bcs-Ing-projects-will-reduce-global-ghg-emissions-and-air-pollution-experts-say/>

Library, Sindh Environmental Protection Agency, 2016

National Environmental Policy, GoP, 2005

National Environmental Policy, 2005.

National Climate Change Policy, 2011.

National Power Policy, 2013

pakistancode.gov.pk, 2005

Sindhforests.gov.pk

Total Gas Demand on System, 2013. Internal Documents of Ministry of Petroleum and Natural Resources. Islamabad, Pakistan

The Pakistan code (The Factories Act, 1934)Total Gas Demand on System, 2013. Internal Documents of Ministry of Petroleum and Natural Resources. Islamabad, Pakistan

The Sindh Environmental Quality Standards (Self-Monitoring and Reporting by Industry) Rules, 2014

The Employment Tribunals Rules of Procedure 2013

[www.fmu.gov.pk](http://www.fmu.gov.pk)